

◆ FEATURES

- ✿ High accuracy, less than $\pm 0.5\%$ error over a dynamic range of 2500: 1
- ✿ High stability of large signal, in the condition of signal 300mA, less than $\pm 0.2\%$ error in the output frequency fluctuation (CF).
- ✿ High stability of small signal, in the condition of signal 50mA, less than $\pm 0.3\%$ error in the output frequency fluctuation (CF).
- ✿ Current and voltage RMS, current measurement range (8mA ~ 30A) @ 1mohm
- ✿ On-Chip anti-creep protection
- ✿ On-Chip power supply detector
- ✿ On-Chip voltage reference of 1.1V(typical)
- ✿ On-chip oscillator as clock source,
- ✿ Single 3.3V supply, low power (8 mW typical)
- ✿ SOP8

◆ DESCRIPTION

BL0937B is a wide range of single-phase multi-function energy meter IC for single-phase socket, Smart Appliance, with a low cost and high accuracy.

BL0937B integrates two high-accuracy Sigma-Delta ADC, voltage reference, power management and other analog circuit modules, and digital signal processing circuit to calculate active power, IRMS, VRMS etc. High frequency CF1 is provided for indicating IRMS/VRMS and high frequency CF for energy metering.

BL0937B can measure the single-phase active energy, active power, current and voltage RMS and other parameters to fully meet the needs of the socket, power strip, smart appliances and others.

Interrelated patents are pending.

◆ BLOCK DIAGRAM

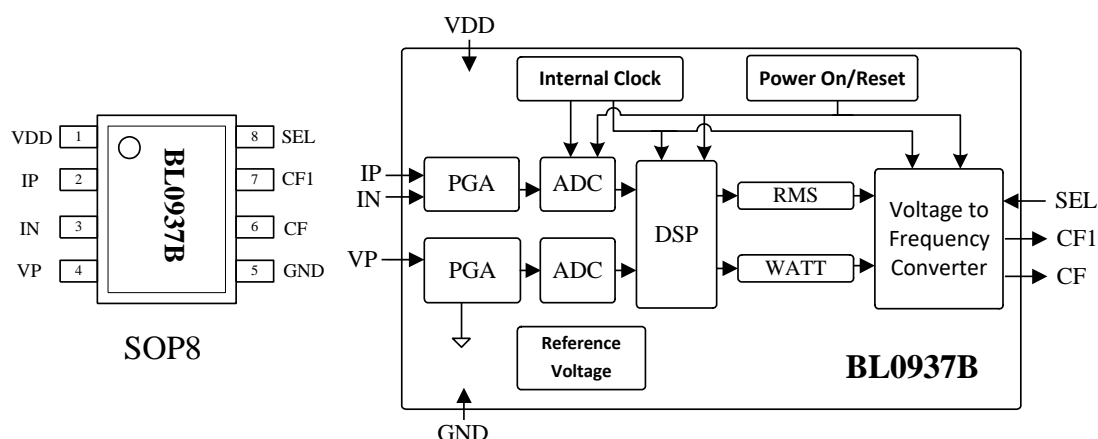

◆ PIN DESCRIPTIONS

Pin	Symbol	DESCRIPTIONS
1	VDD	Power Supply (+3.3V). Provides the supply voltage for BL0937B It should be maintained at 3.0V~3.6V when IC is working
2,3	IP, IN	Inputs for Current Channel. These inputs are fully differential voltage inputs with a maximum signal range of $\pm 50\text{mVpp}$ (35mv rms).
4	VP	Positive Input for Voltage Channel. The Voltage Inputs is differential voltage inputs with a maximum signal range of $\pm 200\text{mVpp}$ (141mV rms).
5	GND	Ground Reference.
6	CF	1) High frequency pulse output for active power, the high pulse width is fixed to 36 μ S(typical); the frequency is proportional to the active power value. 2) Over-current indication pin; If over-current occurs, the pin output 7.8KHz(typical) pulse.
7	CF1	SEL=0, the output indicates current RMS, high pulse width is fixed to 36 μ S(typical), The frequency is proportional to the current RMS value; SEL=1, the output indicates voltage RMS, high pulse width is fixed to 36 μ S(typical), The frequency is proportional to the voltage RMS value;
8	SEL	CF1 output select PIN. Internal pull-down resistor.

◆ Package Dimensions

SOP8

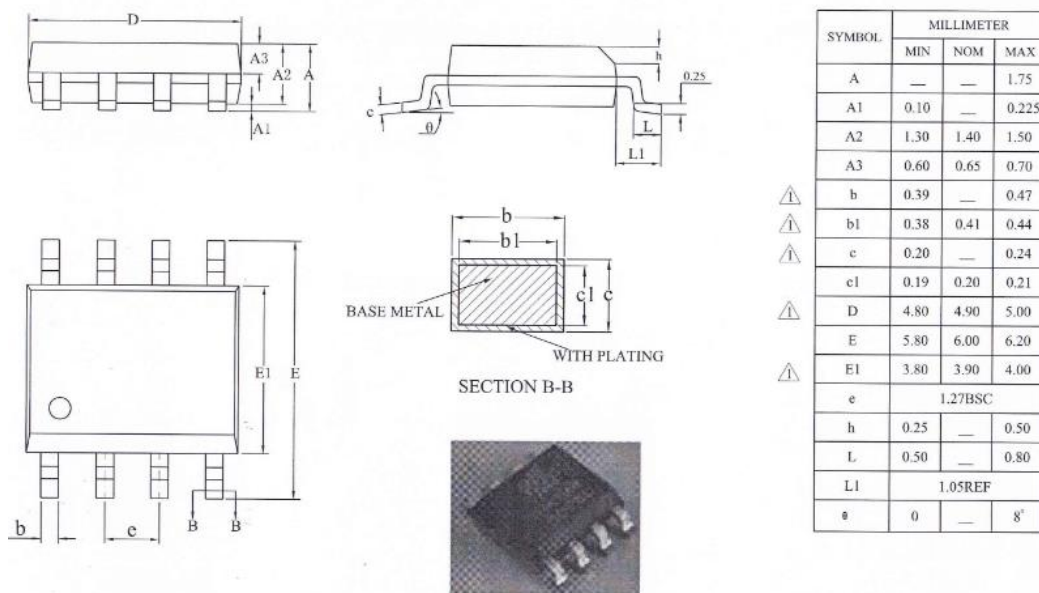

◆ Marking Information

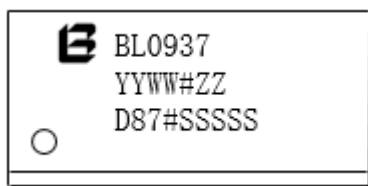

“YY” represents the packaging year; “WW” represents packaging week;
 “SSSSS” represents LOT Number

◆ ABSOLUTE MAXIMUM RATINGS

(T = 25 °C)

Parameter	Symbol	Value	Unit
Power Voltage VDD	VDD	-0.3 ~ +4	V
Analog Input Voltage to GND	IP、IN、VP	-4 ~ +4	V
Digital Input Voltage to GND	SEL	-0.3 ~ VDD+0.3	V
Digital Output Voltage to GND	CF、CF1	-0.3 ~ VDD+0.3	V
Operating Temperature Range	Topr	-40 ~ +85	°C
Storage Temperature Range	Tstr	-55~+150	°C

◆ ELECTRONIC CHARACTERISTIC PARAMETER

(VDD=3.3V, GND=0V, On-Chip voltage reference, 25°C)

Parameter	Symbol	Test Condition	Measure Pin	Min Value	Typical Value	Max Value	Unit
Power Supply	VDD			3.0		3.6	V
Power Dissipation	Iop	VDD=3.3V			2.4		mA
Measure Error on Active Power(Absolute error)	WATTerr	a dynamic range 2500 to 1	CF		0.3	0.5	%
Measure fluctuation error on Active Power(Large signal)	$\Delta@6\%I_b$, Ib=5A	300mA@1mohm,	CF		0.1	0.2	%
Measure fluctuation error on Active Power (Small signal)	$\Delta@1\%I_b$, Ib=5A	50mA@1mohm,	CF		0.15	0.3	%
Phase error when PF=0.8 Capacitive	PF08err	Current lead 37° (PF=0.8)				0.5	%
Phase error when PF=0.5 Inductive	PF05err	Current lags 60° (PF=0.5)				0.5	%
AC PSRR	ACPSRR	IP/N=100mV				0.1	%
DC PSRR	DCPSRR	VP/N=100mV				0.1	%
Vrms measurement Error	VRMSerr		CF1		0.3		%

Irms measurement Error	IRMSer		CF1		0.3		%
Analog Input Voltage(current)		Current differential input (peak)				50	mV
Analog Input Voltage(voltage)		voltage differential input (peak)				200	mV
Analog Input Impedance			VP/IP/IN		370		kΩ
SEL pull-down resistor		SEL (pull-down)			56		kΩ
Input Signal Bandwidth		(-3dB)			3.5		kHz
On-chip voltage reference	Vref		VREF		1.1		V
Input High Voltage		VDD=3.3V ± 5%		2.6			V
Input Low Voltage		VDD=3.3V ± 5%				0.8	V
Output High Voltage		VDD=3.3V ± 5% IOH=5mA		VDD-0.5			V
Output Low Voltage		VDD=3.3V ± 5% IOH=5mA				0.5	V
Over-current threshold		Current sampling resistor 1mΩ			36		A
the frequency of over-current					7.8		kHz
response time of Over-current						200	ms

◆ THEORY OF OPERATION

◆ Principle of Energy Measure

In energy measure, the power information varying with time is calculated by a direct multiplication of the voltage signal and the current signal. Assume that the current signal and the voltage signal are cosine functions; V and I are the peak values of the voltage signal and the current signal; ω is the angle frequency of the input signals; the phase difference between the current signal and the voltage signal is expressed as Φ . Then the power is given as follows:

$$p(t) = V \cos(\omega t) \times I \cos(\omega t + \Phi)$$

$\Phi = 0$:

$$p(t) = \frac{VI}{2} (1 + \cos(2\omega t))$$

$\Phi \neq 0$:

$$\begin{aligned}
 p(t) &= V \cos(\omega t) \times I \cos(\omega t + \Phi) \\
 &= V \cos(\omega t) \times [I \cos(\omega t) \cos(\Phi) + \sin(\omega t) \sin(\Phi)] \\
 &= \frac{VI}{2} (1 + \cos(2\omega t)) \cos(\Phi) + VI \cos(\omega t) \sin(\omega t) \sin(\Phi) \\
 &= \frac{VI}{2} (1 + \cos(2\omega t)) \cos(\Phi) + \frac{VI}{2} \sin(2\omega t) \sin(\Phi)
 \end{aligned}$$

$p(t)$ is called as the instantaneous power signal. The ideal $p(t)$ consists of the dc component and ac component whose frequency is 2ω .

The current and voltage signals are sampled with high precision and converted from analog signals to digital signals. The instantaneous power signal $p(t)$ is obtained after the digital signals are calculated by digital multiplier. In order to extract the real power component (i.e., the dc component), the instantaneous power signal is low-pass filtered, and then accumulated (e.g., by a counter) to generate real energy information. This information is sent to the digital-to-frequency converter module, and converted to a pulse signal of the certain frequency which is proportional to the real power.

Similarly, the voltage and current RMS are calculated and then sent to the digital-to-frequency converter module, converted to a pulse signal of the certain frequency which is proportional to the voltage and current RMS.

◆ Power Supply Monitor

BL0937B contains an on-chip power supply monitor. The power supply (VDD) is continuously monitored by BL0937B. If the supply is less than $2.6V \pm 5\%$, BL0937B will be reset. This is useful to ensure correct device startup at power-up and power-down. The power supply monitor has built in hysteresis and filtering. This prevents wrong triggering which might be induced by noisy jamming. Generally, the decoupling part of power supply should ensure that the ripple on VDD does not exceed $3.3V \pm 5\%$.

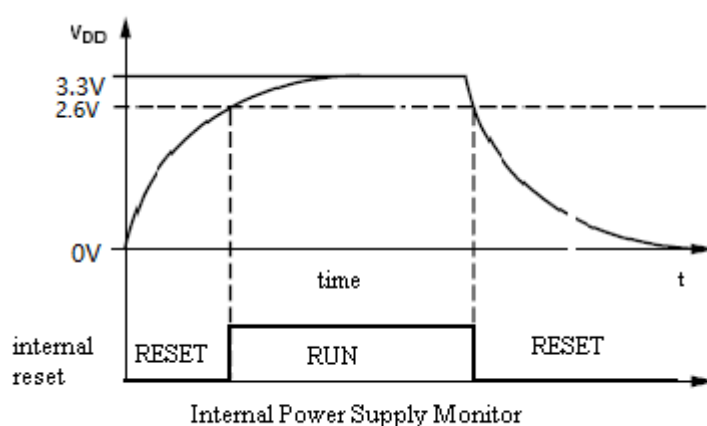

◆ **CHIP APPLICATIONS**

◆ **Typical Application**

BL0937B Typical application block diagram is shown below. Single 3.3V supply. The current signal is sampled through the alloy resistor connected to the IP and IN pins of BL0937B. The voltage signal is sampled through the resistor divider network connected to the VP pin of BL0937B. CF, CF1, SEL directly access to the MCU pin. CF/CF1 pulse cycle is measured to calculate the power, current RMS and voltage RMS.

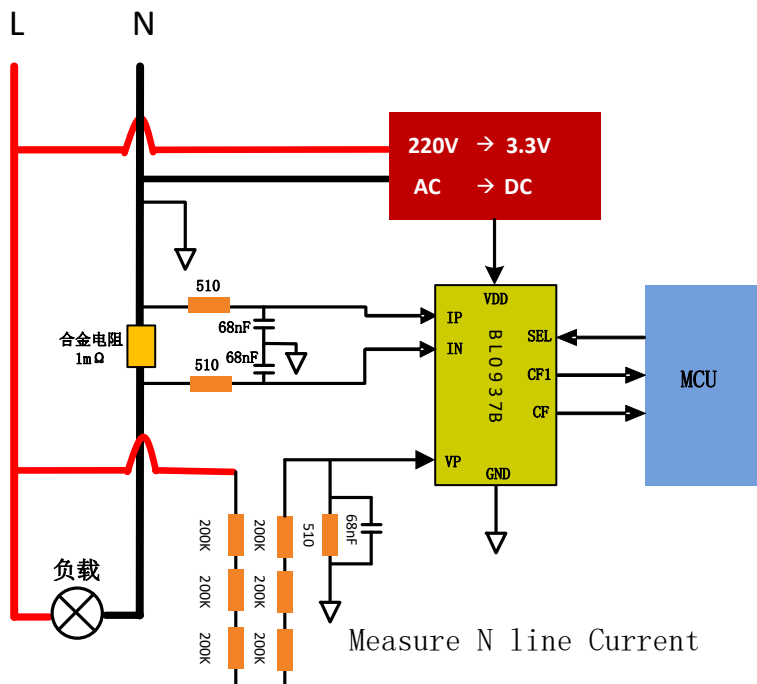
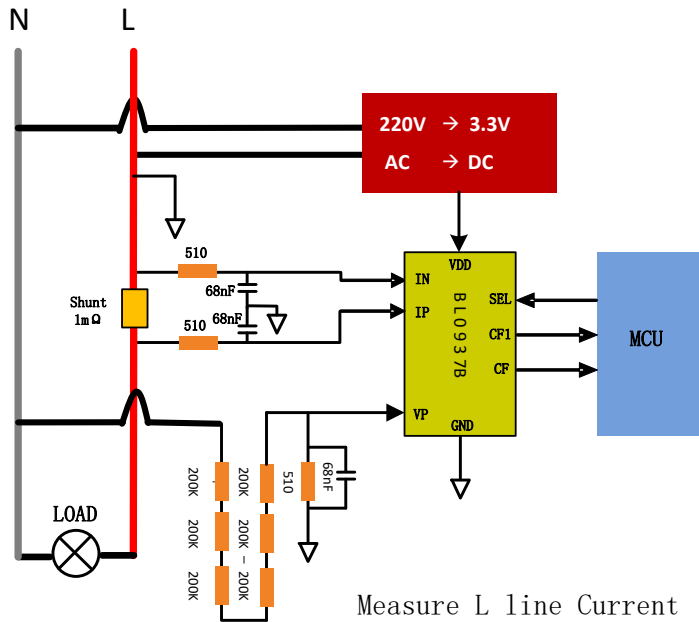

◆ CF、CF1 frequency

BL0937B measures two voltage signals on current channel and voltage channel and then calculates the real power information. This real power information is then converted to a frequency. The frequency information is output on CF in the form of active high pulses. At the same time current RMS and voltage RMS are calculated and converted to a frequency, and output on CF1 in the form of active high pulses.

(1) active power pulse frequency formula(typical):

$$F_{CF} = 1721506 * \frac{V(V) * V(I)}{V_{ref}^2}$$

(2) voltage RMS pulse frequency formula(typical):

$$F_{CFU} = 15397 * \frac{V(V)}{V_{ref}}$$

(3) current RMS pulse frequency formula(typical):

$$F_{CFI} = 94638 * \frac{V(I)}{V_{ref}}$$

V(V)—the voltage RMS of the voltage channel (on IP, IN PIN)

V(I)—the voltage RMS of the current channel (on VP PIN)

Vref—reference voltage (1.1V typical)

Please refer to the application Note for calibration procedures.

◆ Anti-creep

BL0937B has a patented anti-creep design with a reasonable external hardware design to ensure that the noise power is not included in the energy pulse in no load. The anti-creep threshold is 0.0035% of the active power corresponding to the full-scale input signal.

◆ Over-current detection

BL0937B has fast over-current detection function. BL0937B can detect the over-current within 200ms. The pin CF would output over-current signal when over-current occurs. This function helps to design the over-current protection circuit.

◆ Current/voltage RMS output

The current / voltage RMS is output from the pin CF1. When SEL = 0, the CF1 outputs a high frequency pulse of the current RMS; When SEL = 1, the CF1 outputs a high frequency pulse of the voltage RMS. The current and voltage RMS calculation modules of BL0937B are separate internally. SEL switching time $\leq 10\mu\text{s}$.