

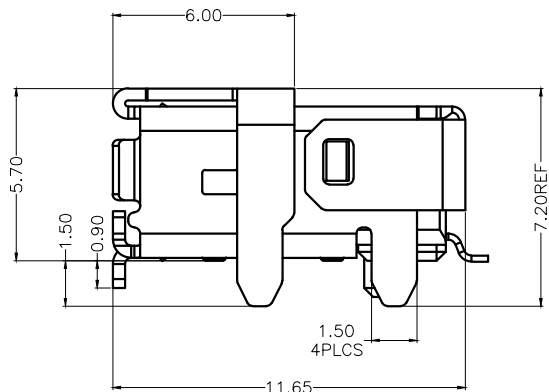

版本	发行日期	发行原因	发行者
A	2024-06-11	新版发行	BYD

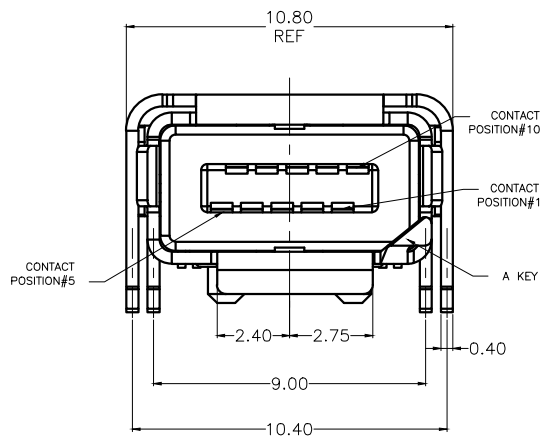

DE93-1B1F002XXX

SERIES, IX INDUSTRIAL

KAY

1:A KAY

2:B KAY

3:C KAY

PLASTIC MATERIAL

B:LCP

COLOUR

1:BLACK

SOCKET / RECEPTACLE

RIGHT ANGLE HORIZONTAL STYLE

PIN

PLATING FOR MATING AREA

1:G/F

2:15u" GOLD

3:30u" GOLD

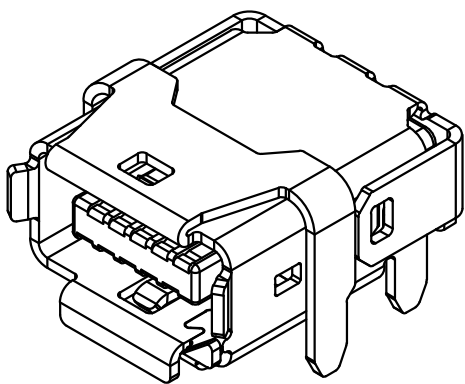
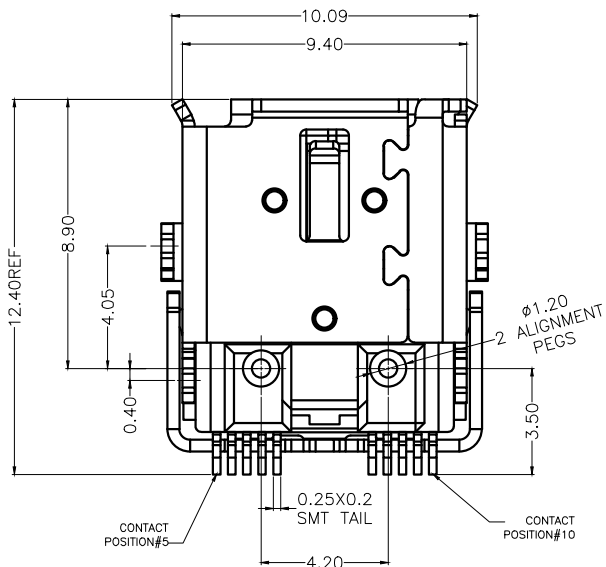

NOTES:

- MATERIAL: RoHS COMPLIANT PER EU DIRECTIVE 2011/65/EU AND AMENDMENTS. STAINLESS STEEL, MATTE TIN OVER NICKEL PLATED. INSERTS: HIGH TEMPERATURE RESISTANT ENGINEERING THERMOPLASTIC, GLASS REINFORCED, UL94V-0.
- CONTACTS: COPPER ALLOY PLATED WITH GOLD OR PALLADIUM-NICKEL (SEE ORDERING CODE) OVER 1.27 μ m (50 μ ") MINIMUM NICKEL ON THE MATING AREA AND MATTE TIN OVER NICKEL ON THE SMT TAILS. CODE 4 MATING AREA PLATING 1.27 μ m (50 μ ") GOLD OPTION CONFORMS TO ASTM B488, TYPE 2, CODE C, CLASS 1.25.
- MID-PLATE: STAINLESS-STEEL
- CONNECTORS ARE PROVIDED IN TAPE & REEL PACKAGING FOR PICK & PLACE PROCESSING AND ARE SUITABLE FOR IR REFLOW SOLDERING OF PIN IN PASTE SHIELD TAILS AND SURFACE MOUNT CONTACT TAILS.
- DESIGNED TO CONFORM TO REQUIREMENTS OF IEC 61076 PART 3-124 SPECIFICATION. THE A KEY FEATURE SHOWN IS INTENDED FOR USE WITH ETHERNET APPLICATIONS, EITHER 10/100 MBit/S OR 1 TO 10 GBit/S (CAT 5e, 6 & 6A).
- CURRENT RATING: 1.5 A PER POSITION (30° MAX TEMPERATURE RISE PER UL1977 & CSA C22.2 NO 182.3 STANDARDS) VOLTAGE RATING: 50V AC rms OR 60V DC
- OPERATING TEMPERATURE -55° TO +105°C.
- DIELECTRIC WITHSTANDING VOLTAGE: 500V DC
- CONTACT RESISTANCE: 30 MILLIOHMS MAXIMUM.
- INSULATION RESISTANCE: 500 MEGOHMS MINIMUM.
- MATING & UNMATING FORCE: 25N (5.6 lbf) MAXIMUM.

APPROVE	TITLE IX INDUSTRIAL CONNECTOR, 10 POSITION A KEY RIGHT ANGLE HORIZONTAL STYLE,SMT TERMINATION,CAT 6A HIGH SPEED PERFORMANCE,RoHS COMPLAINT					DELEC		東莞多亞電子有限公司 Dongguan Duoya Electronics Co.,Ltd		
CHECK	PART NO. DE93-1B1F002XXX					GENERAL TOLERANCE			UNITS mm	SIZE A4
DRAW	REV	DATE	DRAW	CHECK	APPROVE	.X \pm 0.15	X° \pm 2°	SCALE 4:1	SHEET 1/3	REV A
	A	2024-06-11	Wshping	Wshping	Dr	.XX \pm 0.10	X° \pm 0.5°			
						.XXX \pm				



ON CONDUCTIVE TRACES IN THE HATCHED AREA

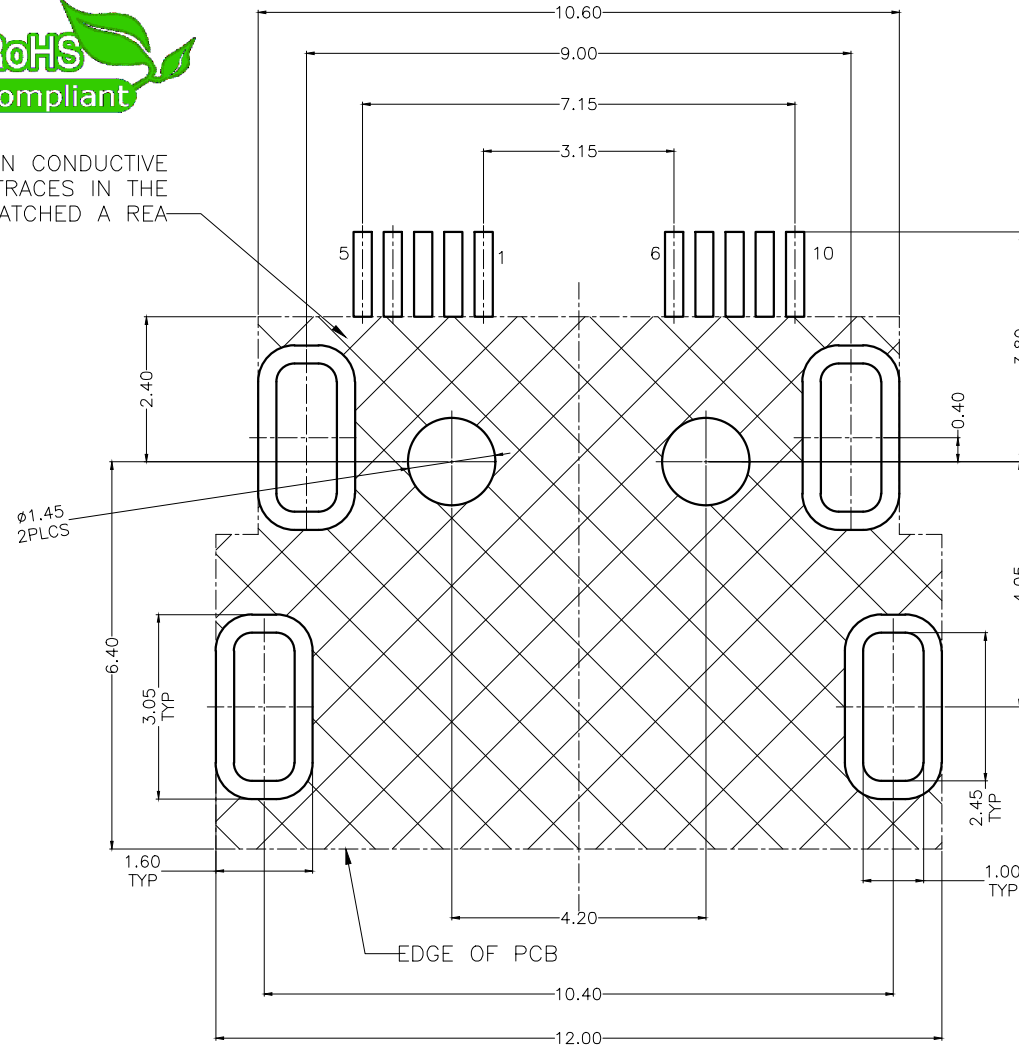

RECOMMENDED PCB LAYOUT
 COMPONENT SIDE OF BOARD
 SCALE 15:1
 GENERAL TOLERANCE ± 0.05
 FOR THIS VIEW

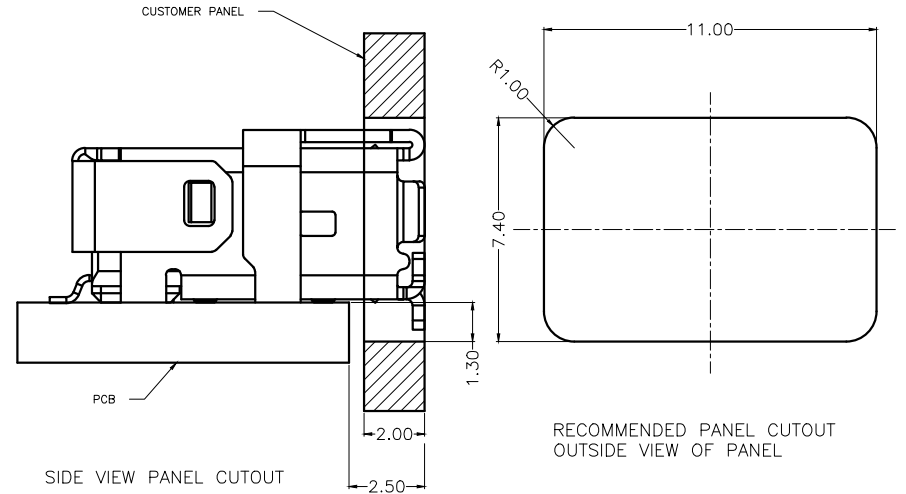

CONNECTOR PIN ASSIGNMENT		
POSITION NUMBER	PIN ASSIGNMENT 10 OR 100 Mbit/S ETHERNET	PIN ASSIGNMENT 1, 2.5, 5 OR 10 Gbit/S ETHERNET
1	TX+	BI_DA+
2	TX-	BI_DA-
3	NOT USED	GND
4	NOT USED	BI_DC+
5	NOT USED	BI_DC-
6	RX+	BI_DB+
7	RX-	BI_DB-
8	NOT USED	GND
9	NOT USED	BI_DD+
10	NOT USED	BI_DD-

版本	发行日期	发行原因	发行者
A	2024-06-11	新版发行	SXP/STB

APPROVE	TITLE IX INDUSTRIAL CONNECTOR, 10 POSITION A KEY RIGHT ANGLE HORIZONTAL STYLE, SMT TERMINATION, CAT 6A HIGH SPEED PERFORMANCE, RoHS COMPLIANT				
CHECK	PART NO. DE93-1B1F002XXX				
DRAW	REV	DATE	DRAW	CHECK	APPROVE
	A	2024-06-11	Wshping	Wshping	Dr



東莞多亞電子有限公司
 Dongguan Duoya Electronics Co., Ltd

GENERAL TOLERANCE		UNITS	SIZE
.X \pm 0.15 X. $^{\circ}$ \pm 2 $^{\circ}$.XX \pm 0.10 X. $^{\circ}$ \pm 0.5 $^{\circ}$.XXX \pm		mm	A4
SCALE	8:1	SHEET	REV
		2/3	A



版本	发行日期	发行原因	发行者
A	2024-06-11	新版发行	S.H.P.S.M.B

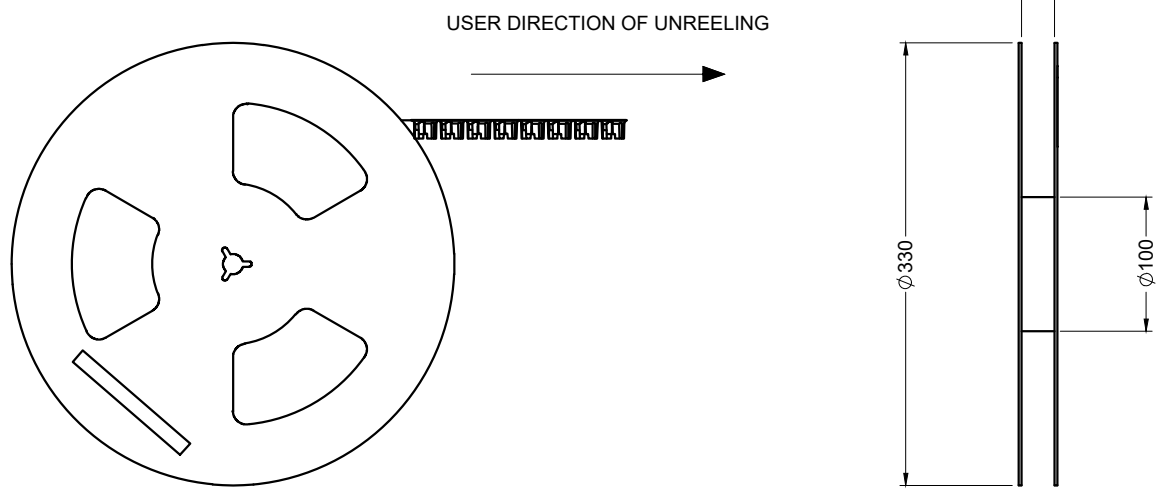
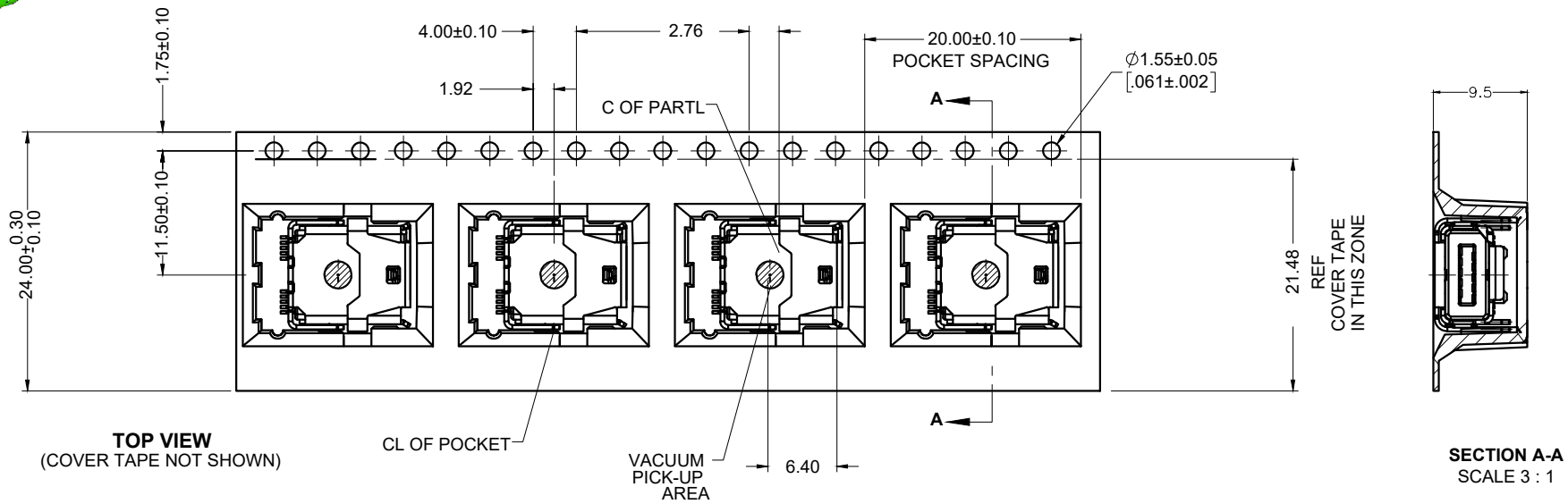

PACKAGING NOTES:
 1.EACH REEL TO CONTAIN A QUANTITY OF 240 CONNECTORS.
 2.EACH FULL CARTON TO CONTAIN A QUANTITY OF 9 REELS
 TOTAL OF 2160 CONNECTORS.

APPROVE	TITLE IX INDUSTRIAL CONNECTOR, 10 POSITION A KEY RIGHT ANGLE HORIZONTAL STYLE,SMT TERMINATION,CAT 6A HIGH SPEED PERFORMANCE,RoHS COMPLAINT					DELEC		東莞多亞電子有限公司 Dongguan Duoya Electronics Co.,Ltd		
CHECK	PART NO. DE93-1B1F002XXX					GENERAL TOLERANCE			UNITS mm	SIZE A4
DRAW	REV	DATE	DRAW	CHECK	APPROVE	.X± 0.15	X.°± 2°	SCALE 8:1	SHEET 3/3	REV A
	A	2024-06-11	Wshping	Wshping	De	.XX± 0.10	X°± 0.5°			
						.XXX±				