



SPECIFICATION FOR APPROVAL

DELEC		
MARKETING GROUP	R&D GROUP	QA GROUP
ISSUED BY	CHECKED BY	QA INSPECTION
Jun Tang	Weide Li	Liu Ting

CUSTOMER

CUSTOMER APPROVAL:

APPROVAL CONCESSIONARY REJECTED

ISSUED BY : _____

CHECKED BY: _____

APPROVED BY: _____

COMMENTS : _____

CUSTOMER: _____

CUSTOMER PART NO: _____

SAMPLE Q'TY: _____

TITLE 6P6C SIDE ENTRY WITHOUT SHIELDED				DELEC		东莞多亚电子有限公司 DONGGUAN DUOYA ELECTRONICS CO., LTD		
PART NO. DE53-1A11034-007				GENERAL TOLERANCE			UNIT:MM (INCH)	SIZE: A4
DRAW	Jun	DATE	2017-05-10	.X±0.20	.X±1°	SCALE: 1:1	SHEET: 1/4	REV:A
CHECK	Peter	DATE	2017-05-10	.XX±0.15	.XX±0.5°			
APPROVE	De	DATE	2017-05-10	.XXX±0.10				



MECHANICAL DIMENSION

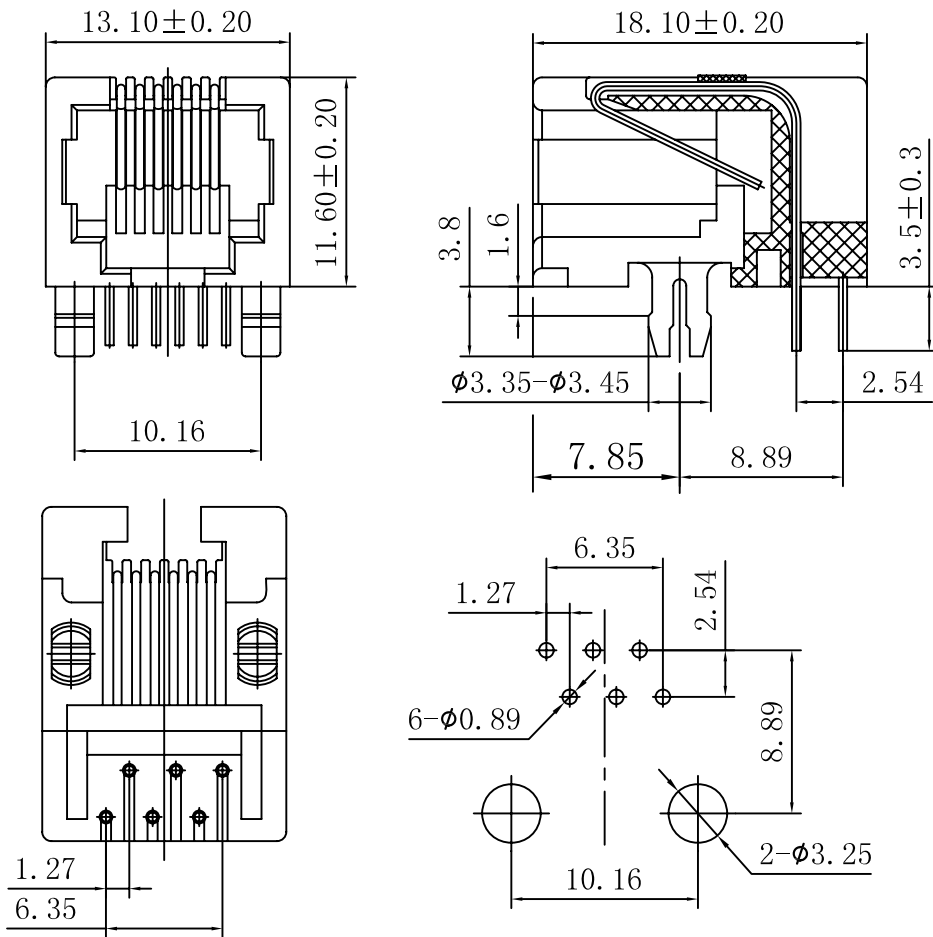

RECOMMENDED PCB LAYOUT
(COMPONENT SIDE VIEW)

SPECIFICATION AND PERFORMANCE

1 Scope

This specification covers the requirements for product performance, tests and quality assurance provisions for side entry PCB jack

2 Applicable document

The following documents form a part of this specification to the extent specified herein. In the event of conflict between the requirements of this specification and the product drawing shall take precedence

3 Materials

Housing: thermoplastic PA46, flammability rating UL94V-0, pantone Black
 Contact: phosphor bronze 0.46mm Round Pin
 Plating: 3 u" Gold plating over nickel
 PCB retention fre-solder: 1LB min.

4 Mechanical characteristics:

Durability: 750(modular jack) insertion/plug dimension cycles

5 Electrical

Current rating: 1.5AMP
 Voltage rating: 125VAC max.
 Contact resistance: 30 milliohms max.
 Insulation resistance: 500 megohms min.@500 VDC.
 Dielectric strength: 1000 VAC RMS 60Hz, 1min.

6 Environmental:

Operating temperature: -40°C~+85°C
 Storage temperature: -40°C~+85°C
 Mates with modular plug conforming to FCC part 68 subpart F.

7 Applicable printed circuit board

The product is designed to meet the electrical, mechanical and environmental performance requirements specified in product drawing

TITLE 6P6C SIDE ENTRY WITHOUT SHIELDED				东莞多亚电子有限公司 DONGGUAN DUOYA ELECTRONICS CO., LTD	
PART NO. DE53-1A11034-007				GENERAL TOLERANCE	UNIT:MM (INCH) SIZE: A4
DRAW	Jun	DATE	2017-05-10	.X±0.20	.X±1°
CHECK	Peter	DATE	2017-05-10	.XX±0.15	.XX±0.5°
APPROVE	De	DATE	2017-05-10	.XXX±0.10	
				SCALE: 1:1	SHEET: 3/4 REV:A



PACKAGE INFORMATION AND LABEL

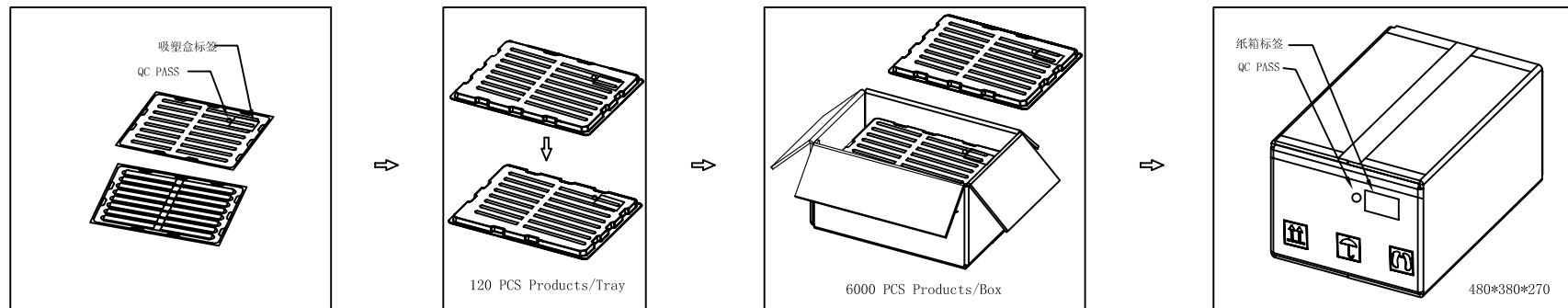

PACKING QUANTITY : 120 PCS FINISHED GOODS PER TRAY
 50 TRAYS (6000 PCS FINISHED GOODS) PER CARTON BOX

TITLE 6P6C SIDE ENTRY WITHOUT SHIELDED				DELEC		东莞多亚电子有限公司 DONGGUAN DUOYA ELECTRONICS CO., LTD		
PART NO. DE53-1A11034-007				GENERAL TOLERANCE			UNIT:MM (INCH)	SIZE: A4
DRAW	Jun	DATE	2017-05-10	.X±0.20	.X±1°	SCALE: 1:1	SHEET: 4/4	REV:A
CHECK	Peter	DATE	2017-05-10	.XX±0.15	.XX±0.5°			
APPROVE	De	DATE	2017-05-10	.XXX±0.10				