

# SPECIFICATION FOR APPROVAL

<b>DELEC</b>		
MARKETING GROUP	R&D GROUP	QA GROUP
ISSUED BY	CHECKED BY	QA INSPECTION
Iror	De	XuLong

## CUSTOMER

CUSTOMER APPROVAL:

APPROVAL     CONCESSIONARY     REJECTED

ISSUED BY : \_\_\_\_\_

CHECKED BY: \_\_\_\_\_

APPROVED BY: \_\_\_\_\_

COMMENTS : \_\_\_\_\_  
 \_\_\_\_\_

CUSTOMER: \_\_\_\_\_

CUSTOMER PART NO: \_\_\_\_\_

SAMPLE Q'TY: \_\_\_\_\_

SAMPLE DATE: \_\_\_\_\_

TITLE SFP+ 1X1 CAGE, WITH HEAT SINK				<b>DELEC</b>		东莞多亚电子有限公司 DONGGUAN DUOYA ELECTRONICS CO., LTD		
PART NO. DH10-2N31220-55N				GENERAL TOLERANCE			UNIT:MM	SIZE: A4
DRAW	Iror	DATE	2019-05-17	.X±0.20	.X±1*	SCALE: 1:1	SHEET: 1/6	REV:A
CHECK	Iror	DATE	2019-05-17	.XX±0.15	.XX±5*			
APPROVE	Victor	DATE	2019-05-17	.XXX±0.10				

RoHS COMPLIANT

1 2 3 4 5 6 7 8

H  
G  
F  
E  
D  
C  
B  
A

ISSUE RECORD

REV	DESCRIPTION OF CHANGE	REVIEWED BY	APPROVED BY	ISSUE DATE
A	FIRST ISSUE	Iror	Victor Ran	2019-05-17

RoHS COMPLIANT

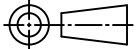
TITLE SFP+ 1X1 CAGE, WITH HEAT SINK						东莞多亚电子有限公司 DONGGUAN DUOYA ELECTRONICS CO., LTD				
PART NO. DH10-2N31220-55N(1)				GENERAL TOLERANCE				UNIT:MM		SIZE: A4
DRAW	Iror	DATE	2019-05-17	.X±0.20	.X±1*	SCALE: 1:1		SHEET: 2/6		REV:A
CHECK	Iror	DATE	2019-05-17	.XX±0.15	.XX±5*					
APPROVE	Victor	DATE	2019-05-17	.XXX±0.10						

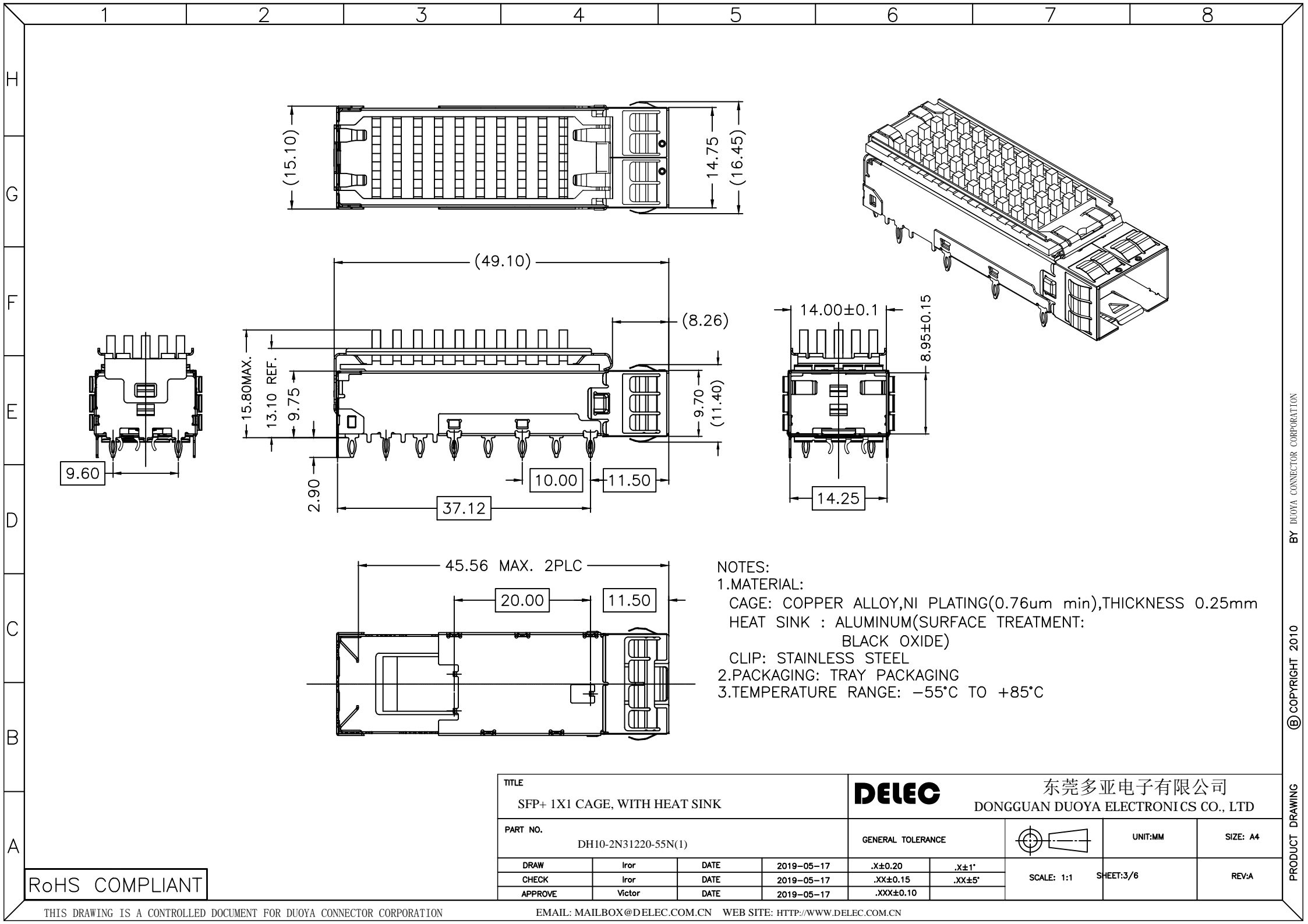

RoHS COMPLIANT

TITLE SFP+ 1X1 CAGE, WITH HEAT SINK				<b>DELEC</b>		东莞多亚电子有限公司 DONGGUAN DUOYA ELECTRONICS CO., LTD		
PART NO. DH10-2N31220-55N(1)				GENERAL TOLERANCE			UNIT:MM	SIZE: A4
DRAW	Iror	DATE	2019-05-17	.X±0.20	.X±1°	SCALE: 1:1	SHEET:3/6	REV:A
CHECK	Iror	DATE	2019-05-17	.XX±0.15	.XX±5°			
APPROVE	Victor	DATE	2019-05-17	.XXX±0.10				

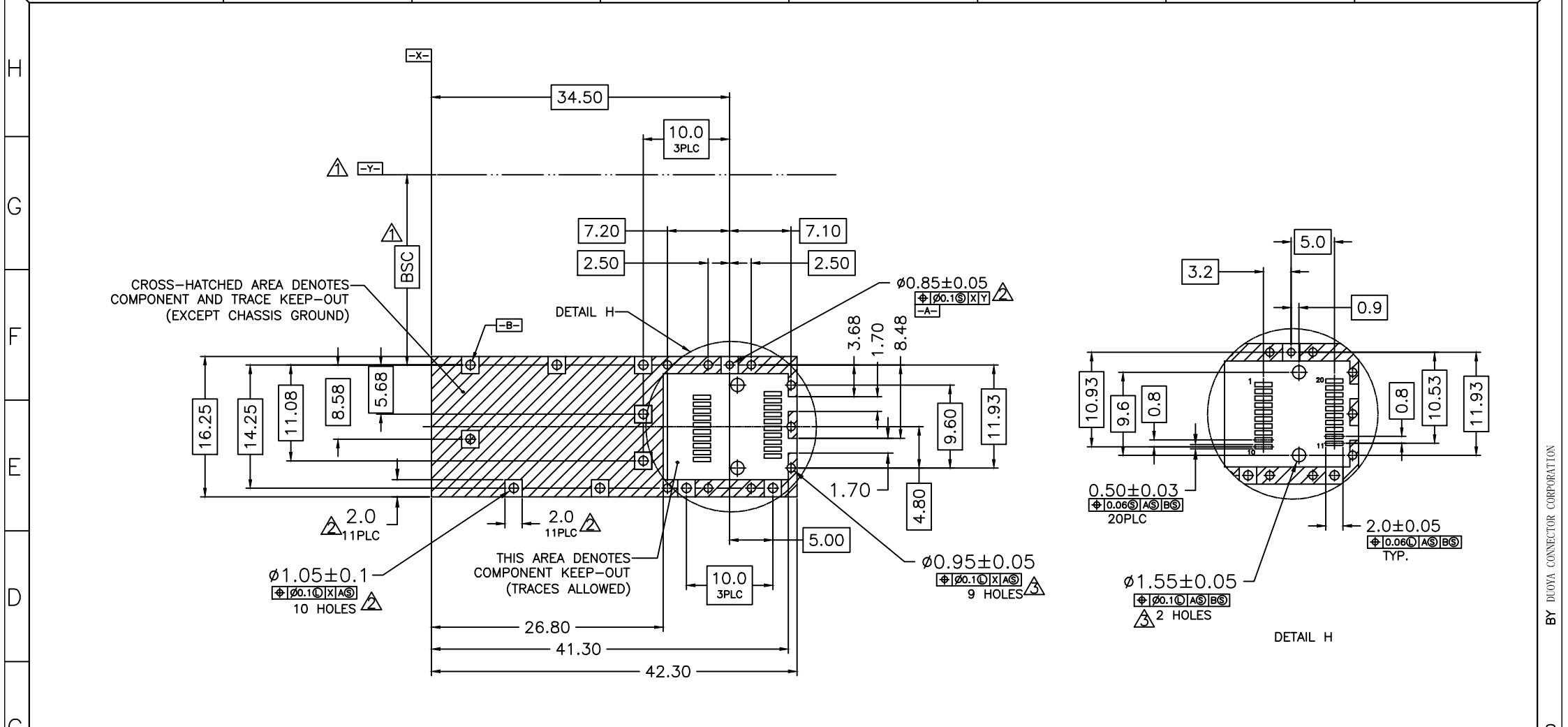

ECOMMENDED PCB CONFIGURATION

NOTES:

- 1. DATUM AND BASIC DIMENSIONS ESTABLISHED BY CUSTOMER
- 2. PADS AND VIAS ARE CHASSIS GROUND, 11 PLACES
- 3. THRU HOLES, PLATING OPTIONAL

TITLE				<b>DELEC</b>		东莞多亚电子有限公司 DONGGUAN DUOYA ELECTRONICS CO., LTD		
SFP+ 1X1 CAGE, WITH HEAT SINK								
PART NO.				GENERAL TOLERANCE			UNIT:MM	SIZE: A4
DH10-2N31220-55N(1)							SCALE: 1:1	SHEET:4/6
DRAW	lror	DATE	2019-05-17	.X±0.20	.X±1'			
CHECK	lror	DATE	2019-05-17	.XX±0.15	.XX±5'			
APPROVE	Victor	DATE	2019-05-17	.XXX±0.10				

RoHS COMPLIANT

NOTES:  
 ▲ MINIMUM PITCH ILLUSTRATED, ENGLISH DIMENSIONS ARE FOR REFERENCE ONLY

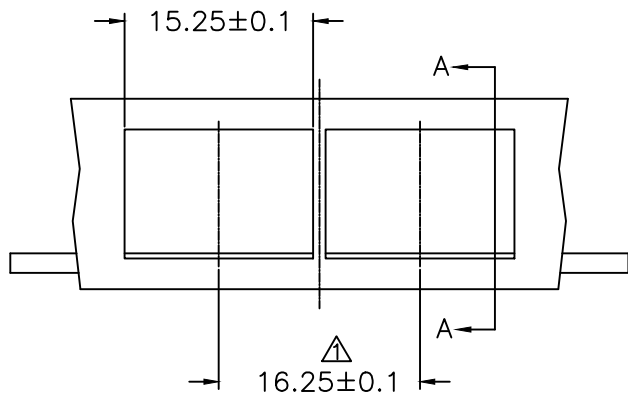

RECOMMENDED BEZEL DESIGN

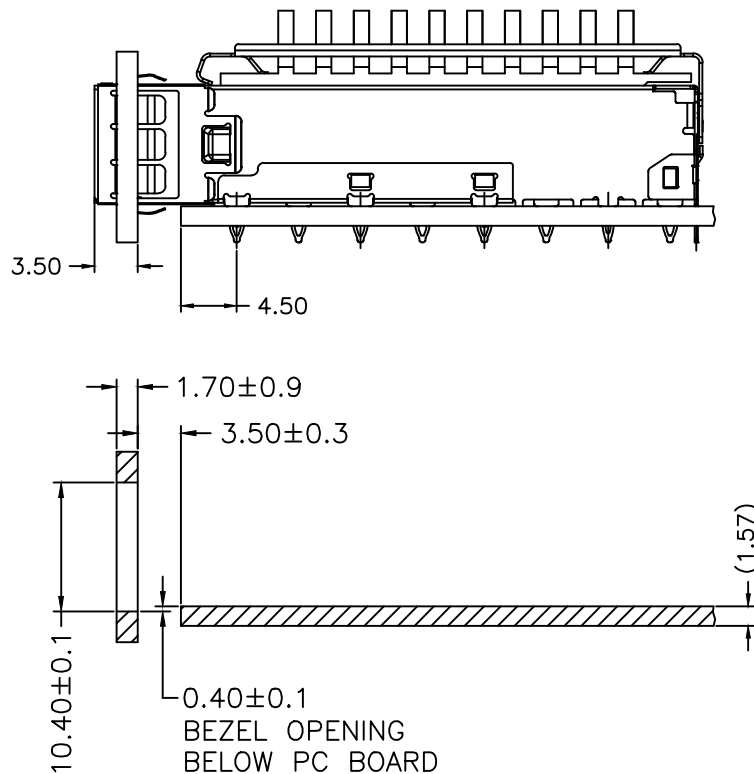

SECTION A-A

RoHS COMPLIANT

TITLE SFP+ 1X1 CAGE, WITH HEAT SINK				<b>DELEC</b>		东莞多亚电子有限公司 DONGGUAN DUOYA ELECTRONICS CO., LTD			
PART NO. DH10-2N31220-55N(1)				GENERAL TOLERANCE			UNIT:MM	SIZE: A4	
DRAW	lror	DATE	2019-05-17	.X±0.20	.X±1°		SCALE: 1:1	SHEET:5/6	REV:A
CHECK	lror	DATE	2019-05-17	.XX±0.15	.XX±5°				
APPROVE	Victor	DATE	2019-05-17	.XXX±0.10					

PACKAGE INFORMATION AND LABLE

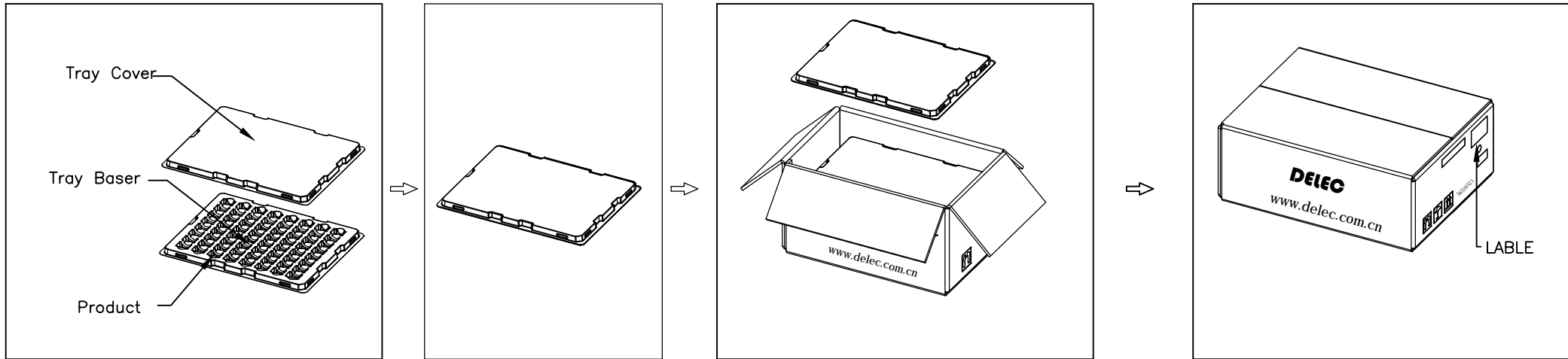

PACKING QUANTITY : 35 PCS FINISHED GOODS PER TRAY  
 5 TRAYS (175 PCS FINISHED GOODS) PER CARTON BOX

RoHS COMPLIANT

TITLE SFP+ 1X1 CAGE, WITH HEAT SINK				<b>DELEC</b>		东莞多亚电子有限公司 DONGGUAN DUOYA ELECTRONICS CO., LTD		
PART NO. DH10-2N31220-55N(1)				GENERAL TOLERANCE			UNIT:MM	SIZE: A4
DRAW	lror	DATE	2019-05-17	.X±0.20	.X±1'	SCALE: 1:1	SHEET: 6/6	REV:A
CHECK	lror	DATE	2019-05-17	.XX±0.15	.XX±5'			
APPROVE	Victor	DATE	2019-05-17	.XXX±0.10				