

# SPECIFICATION FOR APPROVAL

DELEC		
MARKETING GROUP	R&D GROUP	QA GROUP
ISSUED BY	CHECKED BY	QA INSPECTION
Aaron	Aaron	XuLong

## CUSTOMER

CUSTOMER APPROVAL:

APPROVAL       CONCESSIONARY       REJECTED

ISSUED BY : \_\_\_\_\_

CHECKED BY: \_\_\_\_\_

APPROVED BY: \_\_\_\_\_

COMMENTS : \_\_\_\_\_  
 \_\_\_\_\_

CUSTOMER: H3C

CUSTOMER PART NO: 1420A01W

SAMPLE Q'TY: \_\_\_\_\_

SAMPLE DATE: \_\_\_\_\_

**RoHS COMPLIANT**

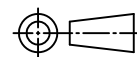
TITLE SFP+ 1X1 CAGE, WITH HEAT SINK				<b>DELEC</b>		东莞多亚电子有限公司 DONGGUAN DUOYA ELECTRONICS CO., LTD		
PART NO. DH10-2N31011-50N				GENERAL TOLERANCE			UNIT:MM	SIZE: A4
DRAW	Aaron	DATE	2020-08-26	.X±0.20	.X±1'	SCALE: 1:1	SHEET: 1/6	REV:A
CHECK	Aaron	DATE	2020-08-26	.XX±0.15	.XX±5'			
APPROVE	Victor	DATE	2020-08-26	.XXX±0.10				



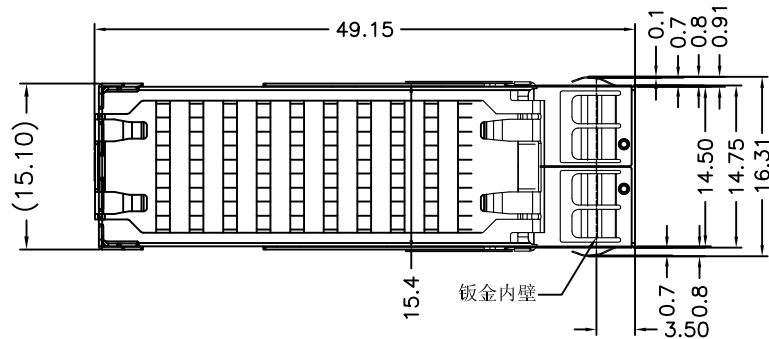

NOTES:  
 1.MATERIAL:  
 CAGE: COPPER ALLOY, THICKNESS 0.25mm  
 HEAT SINK : ALUMINUM(SURFACE TREATMENT:  
 BLACK OXIDE)  
 CLIP: STAINLESS STEEL  
 2.PACKAGING: TRAY PACKAGING  
 3.TEMPERATURE RANGE: -55°C TO +85°C

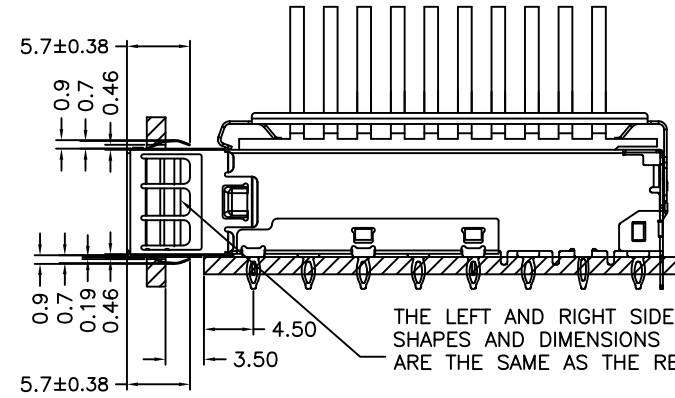
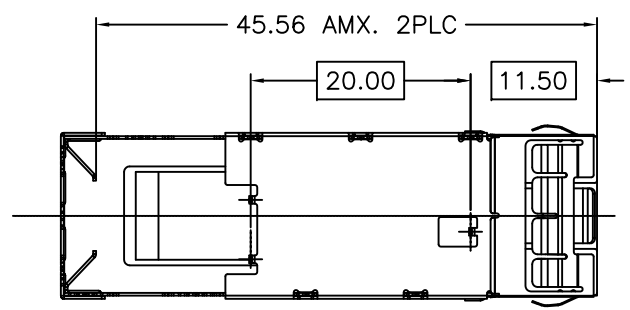
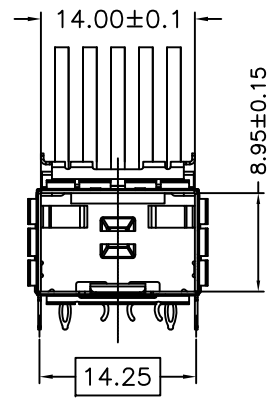
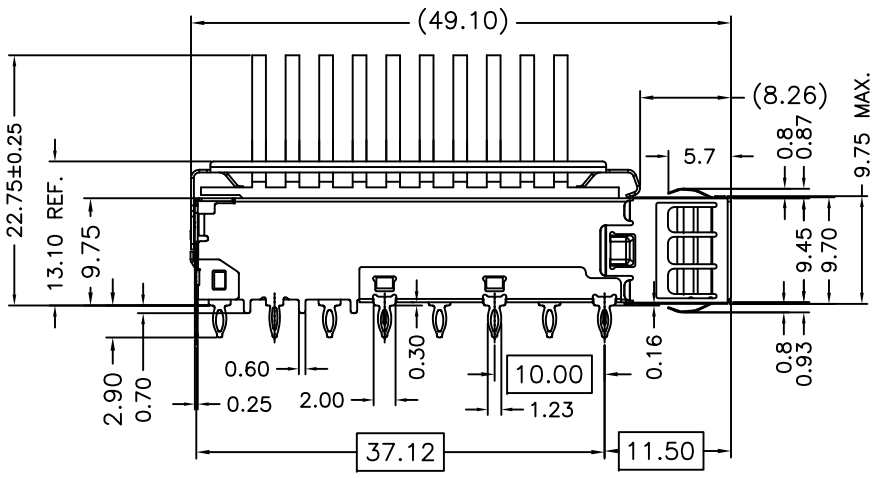
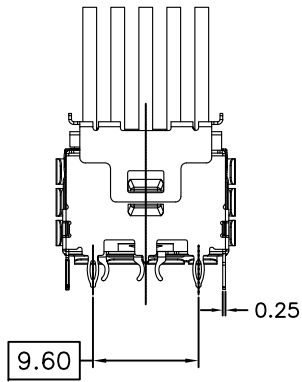

THE LEFT AND RIGHT SIDE REED SHAPES AND DIMENSIONS ARE THE SAME AS THE REED

RoHS COMPLIANT

TITLE				<b>DELEC</b>		东莞多亚电子有限公司 DONGGUAN DUOYA ELECTRONICS CO., LTD		
SFP+ 1X1 CAGE, WITH HEAT SINK								
PART NO.				GENERAL TOLERANCE			UNIT:MM	SIZE: A4
DH10-2N31220-50N							SCALE: 1:1	SHEET:3/6
DRAW	Aaron	DATE	2020-07-09	.X±0.20	.X±1'			
CHECK	Aaron	DATE	2020-07-09	.XX±0.15	.XX±5'			
APPROVE	Victor	DATE	2020-07-09	.XXX±0.10				

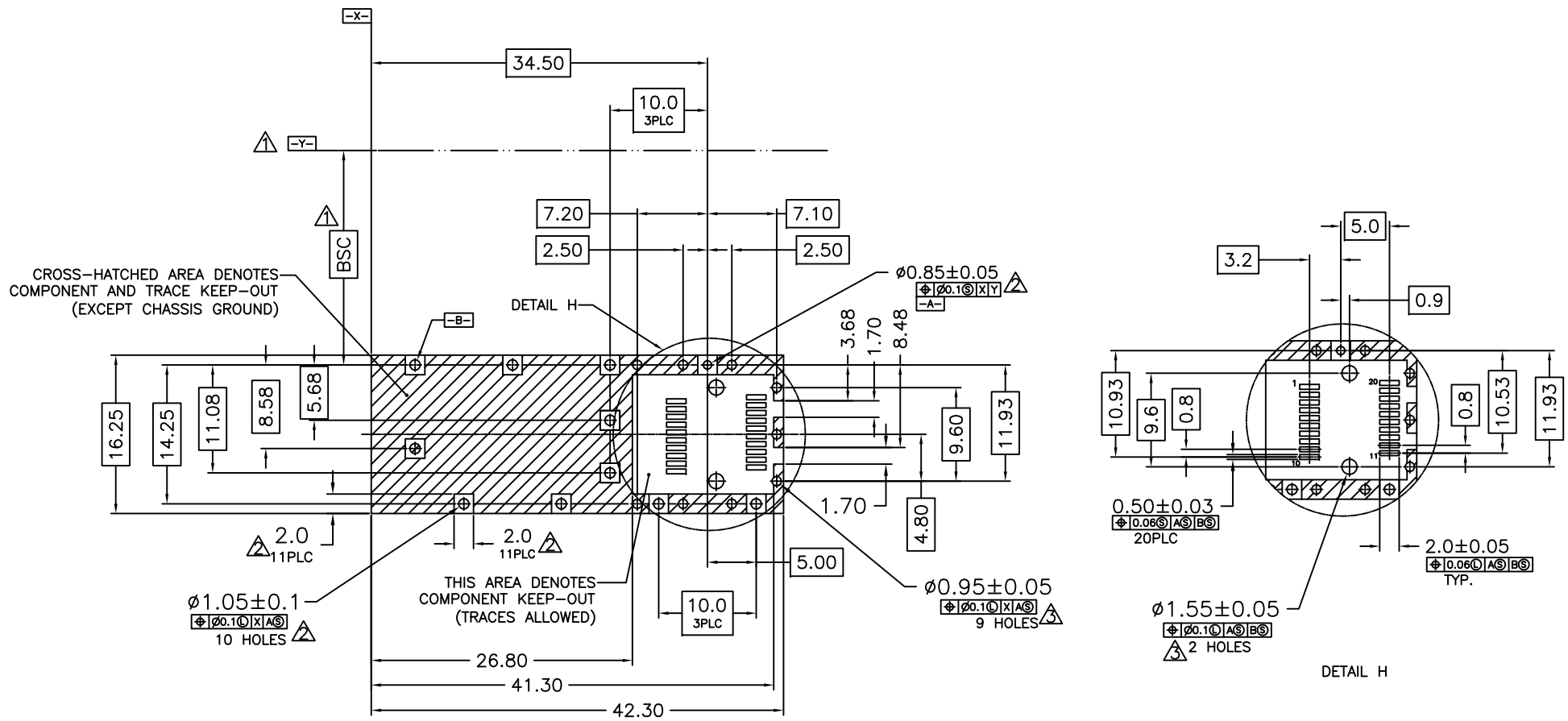

ECOMMENDED PCB CONFIGURATION

NOTES:

- 1. DATUM AND BASIC DIMENSIONS ESTABLISHED BY CUSTOMER
- 2. PADS AND VIAS ARE CHASSIS GROUND, 11 PLACES
- 3. THRU HOLES, PLATING OPTIONAL

RoHS COMPLIANT

TITLE				<b>DELEC</b>		东莞多亚电子有限公司 DONGGUAN DUOYA ELECTRONICS CO., LTD		
SFP+ 1X1 CAGE, WITH HEAT SINK						GENERAL TOLERANCE		
PART NO.				DH10-2N31220-50N		SCALE: 1:1	SHEET:4/6	
DRAW	Aaron	DATE	2020-07-09	.X±0.20	.X±1'			
CHECK	Aaron	DATE	2020-07-09	.XX±0.15	.XX±5'			
APPROVE	Victor	DATE	2020-07-09	.XXX±0.10				

NOTES:  
 ▲ MINIMUM PITCH ILLUSTRATED, ENGLISH DIMENSIONS ARE FOR REFERENCE ONLY

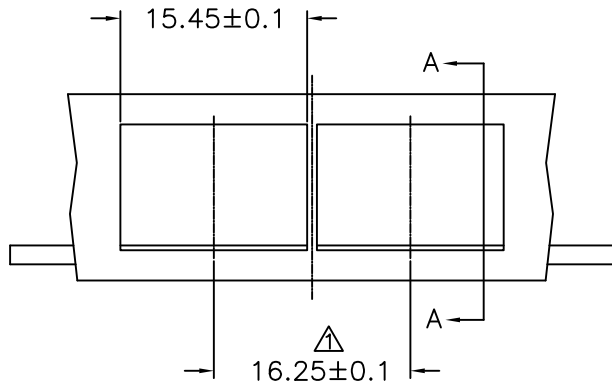

RECOMMENDED BEZEL DESIGN

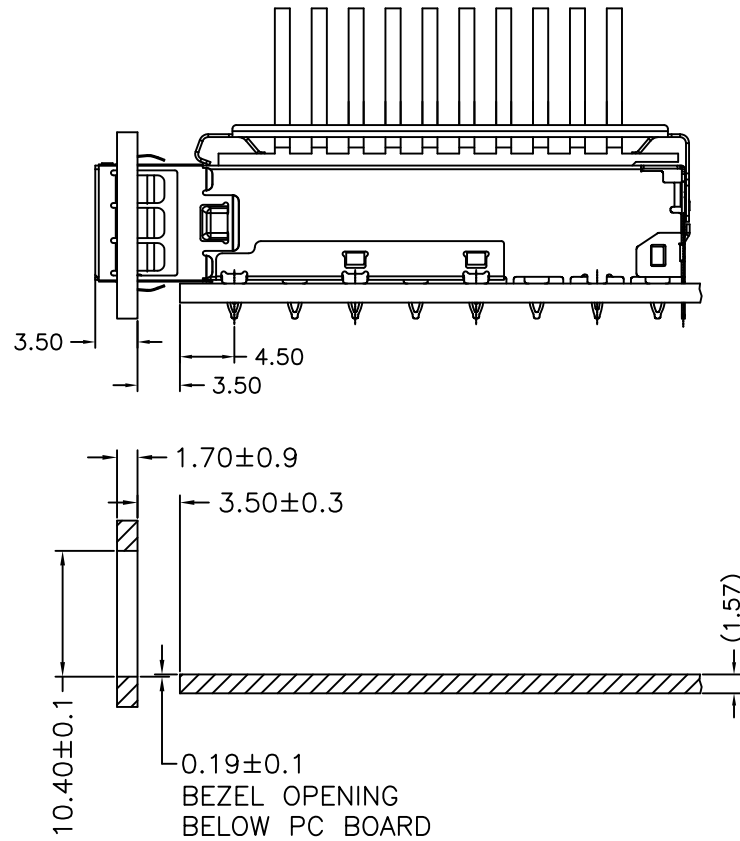

SECTION A-A

RoHS COMPLIANT

TITLE SFP+ 1X1 CAGE, WITH HEAT SINK				<b>DELEC</b>		东莞多亚电子有限公司 DONGGUAN DUOYA ELECTRONICS CO., LTD		
PART NO. DH10-2N31220-50N				GENERAL TOLERANCE			UNIT:MM	SIZE: A4
DRAW	Aaron	DATE	2020-07-09	.X±0.20	.X±1°	SCALE: 1:1	SHEET:5/6	REV:E
CHECK	Aaron	DATE	2020-07-09	.XX±0.15	.XX±5°			
APPROVE	Victor	DATE	2020-07-09	.XXX±0.10				

PACKAGE INFORMATION AND LABEL

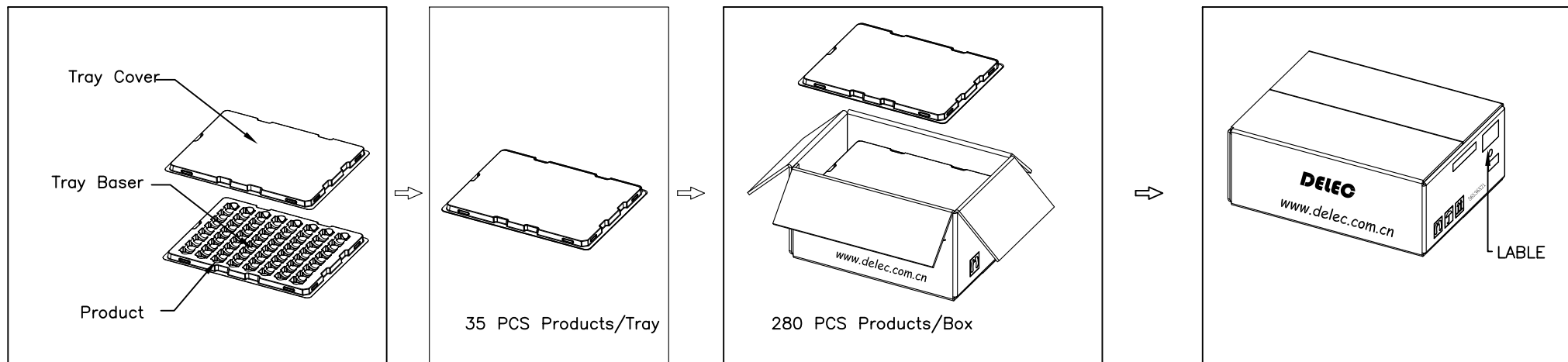

PACKING QUANTITY : 35 PCS FINISHED GOODS PER TRAY

8 TRAYS (280 PCS FINISHED GOODS) PER CARTON BOX

RoHS COMPLIANT

TITLE SFP+ 1X1 CAGE, WITH HEAT SINK				<b>DELEC</b>		东莞多亚电子有限公司 DONGGUAN DUOYA ELECTRONICS CO., LTD		
PART NO. DH10-2N31220-50N				GENERAL TOLERANCE			UNIT:MM	SIZE: A4
DRAW	Aaron	DATE	2020-07-09	.X±0.20	.X±1°	SCALE: 1:1	SHEET: 6/6	REV:E
CHECK	Aaron	DATE	2020-07-09	.XX±0.15	.XX±5°			
APPROVE	Victor	DATE	2020-07-09	.XXX±0.10				