

SPECIFICATION FOR APPROVAL

DELEC		
MARKETING GROUP	R&D GROUP	QA GROUP
ISSUED BY	CHECKED BY	QA INSPECTION
Iror	De	XuLong

CUSTOMER

CUSTOMER APPROVAL:

APPROVAL CONCESSIONARY REJECTED

ISSUED BY : _____

CHECKED BY: _____

APPROVED BY: _____

COMMENTS : _____

CUSTOMER: _____

CUSTOMER PART NO: _____

SAMPLE Q'TY: _____

SAMPLE DATE: _____

RoHS COMPLIANT

TITLE SFP+ 1X1 CAGE, WITH HEAT SINK				DELEC		东莞多亚电子有限公司 DONGGUAN DUOYA ELECTRONICS CO., LTD		
PART NO. DH10-2N31220-52N				GENERAL TOLERANCE			UNIT:MM	SIZE: A4
DRAW	Iror	DATE	2018-04-28	.X±0.20	.X±1'	SCALE: 1:1	SHEET: 1/6	REV:A
CHECK	Iror	DATE	2018-04-28	.XX±0.15	.XX±5'			
APPROVE	Victor	DATE	2018-04-28	.XXX±0.10				

H

G

F

E

D

C

B

A

ISSUE RECORD

REV	DESCRIPTION OF CHANGE	REVIEWED BY	APPROVED BY	ISSUE DATE
A	FIRST ISSUE	Iror	Victor Ran	2018-04-28

TITLE SFP+ 1X1 CAGE, WITH HEAT SINK				DELEC		东莞多亚电子有限公司 DONGGUAN DUOYA ELECTRONICS CO., LTD		
PART NO. DH10-2N31220-52N				GENERAL TOLERANCE			UNIT:MM	SIZE: A4
DRAW	Iror	DATE	2018-04-28	.X±0.20	.X±1"	SCALE: 1:1	SHEET: 2/6	REV:A
CHECK	Iror	DATE	2018-04-28	.XX±0.15	.XX±5"			
APPROVE	Victor	DATE	2018-04-28	.XXX±0.10				

RoHS COMPLIANT

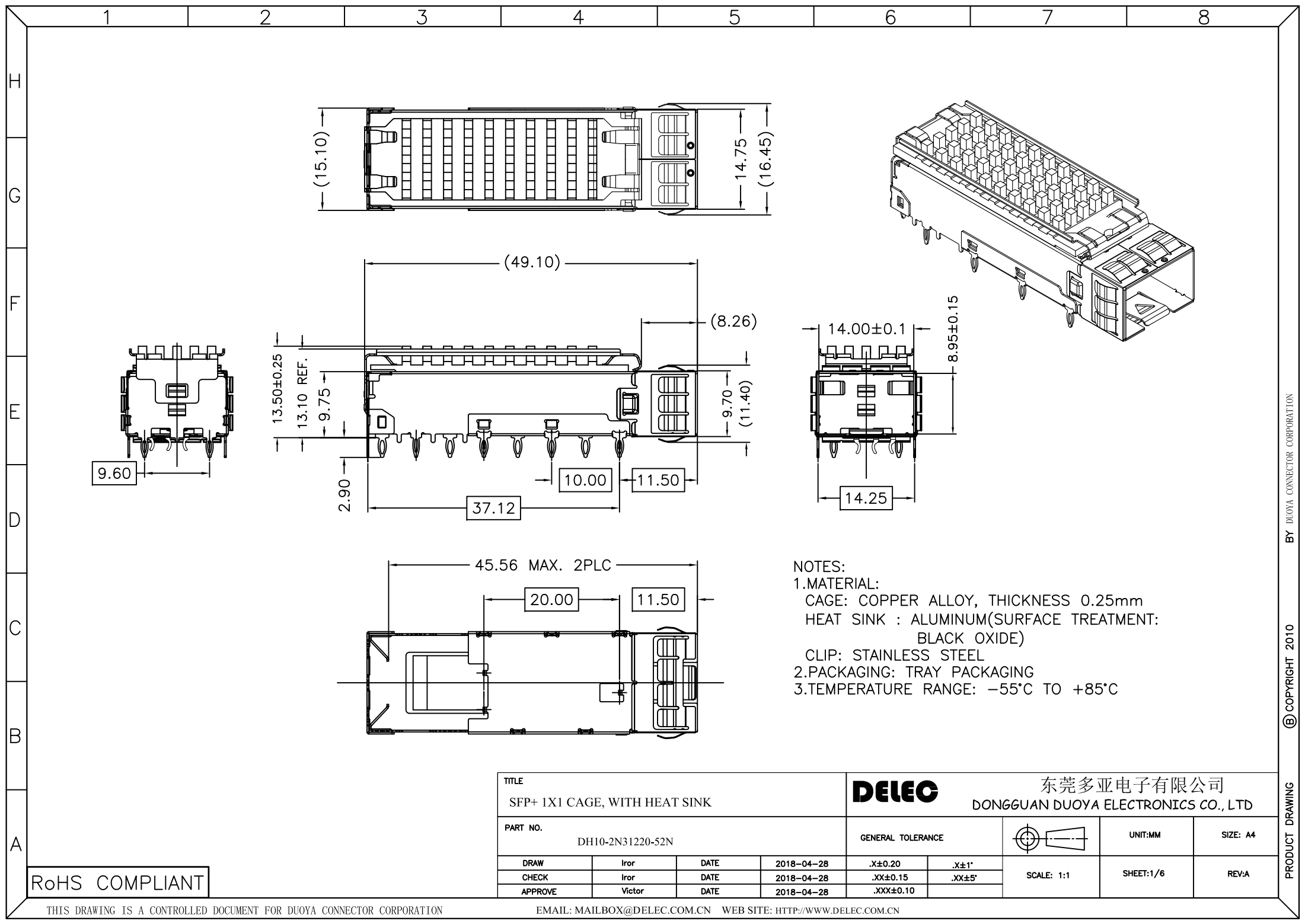

NOTES:
 1.MATERIAL:
 CAGE: COPPER ALLOY, THICKNESS 0.25mm
 HEAT SINK : ALUMINUM(SURFACE TREATMENT:
 BLACK OXIDE)
 CLIP: STAINLESS STEEL
 2.PACKAGING: TRAY PACKAGING
 3.TEMPERATURE RANGE: -55°C TO +85°C

TITLE				DELEC		东莞多亚电子有限公司 DONGGUAN DUOYA ELECTRONICS CO., LTD			
SFP+ 1X1 CAGE, WITH HEAT SINK						GENERAL TOLERANCE		UNIT:MM	
PART NO.				DRAW		CHECK		APPROVE	
DH10-2N31220-52N				Iror		Iror		Victor	
DATE		DATE		DATE		DATE		DATE	
2018-04-28		2018-04-28		2018-04-28		2018-04-28		2018-04-28	
.X±0.20		.XX±0.15		.XXX±0.10		SCALE: 1:1		SHEET:1/6	
.X±1'		.XX±5'				REV:A			

RoHS COMPLIANT

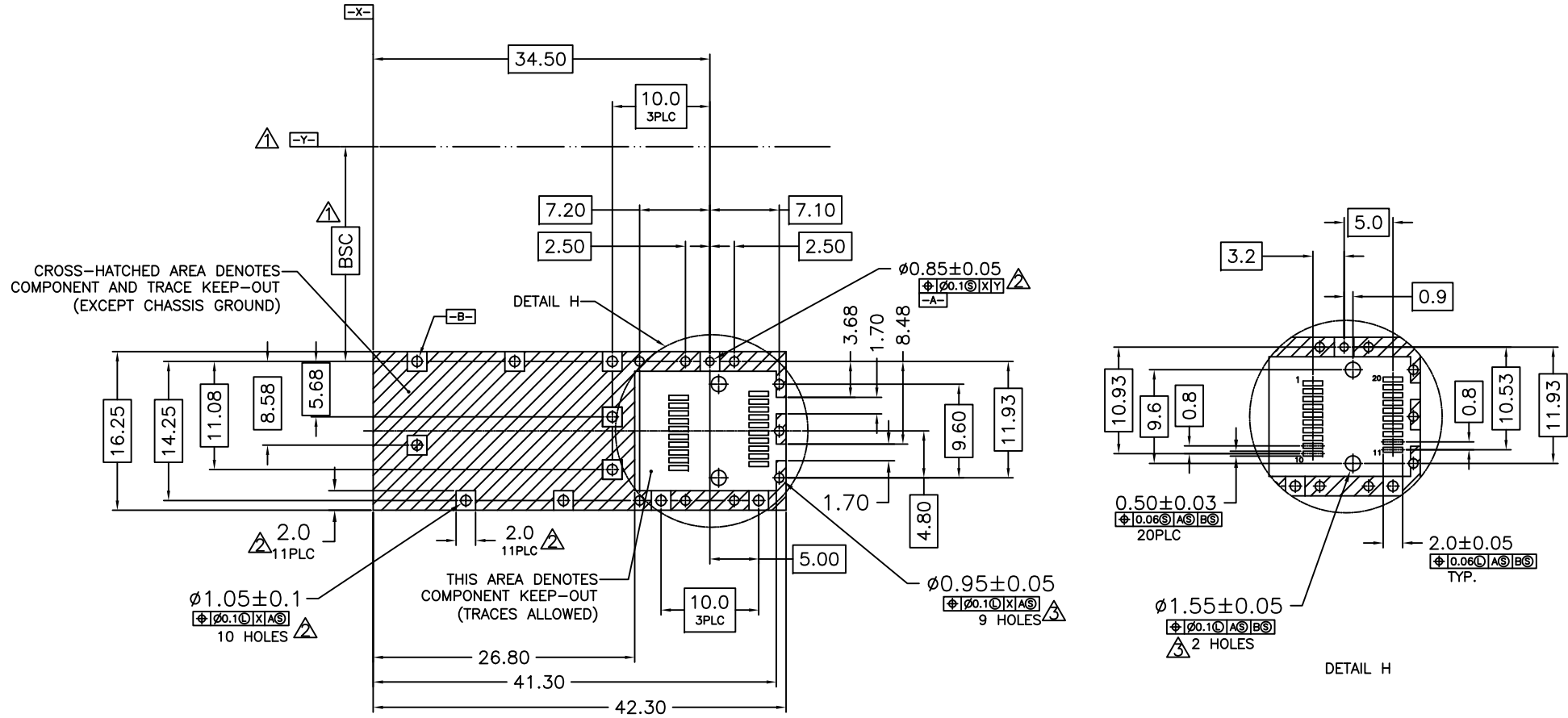

ECOMMENDED PCB CONFIGURATION

NOTES:

- ① DATUM AND BASIC DIMENSIONS ESTABLISHED BY CUSTOMER
- ② PADS AND VIAS ARE CHASSIS GROUND, 11 PLACES
- ③ THRU HOLES, PLATING OPTIONAL

TITLE SFP+ 1X1 CAGE, WITH HEAT SINK				东莞多亚电子有限公司 DONGGUAN DUOYA ELECTRONICS CO., LTD		UNIT:MM SIZE: A4	
PART NO. DH10-2N31220-52N							GENERAL TOLERANCE
DRAW	Iror	DATE	2018-04-28	.X±0.20	.X±1'	SHEET:4/6	
CHECK	Iror	DATE	2018-04-28	.XX±0.15	.XX±5'		REV:A
APPROVE	Victor	DATE	2018-04-28	.XXX±0.10			

RoHS COMPLIANT

NOTES:
 ▲ MINIMUM PITCH ILLUSTRATED, ENGLISH DIMENSIONS ARE FOR REFERENCE ONLY

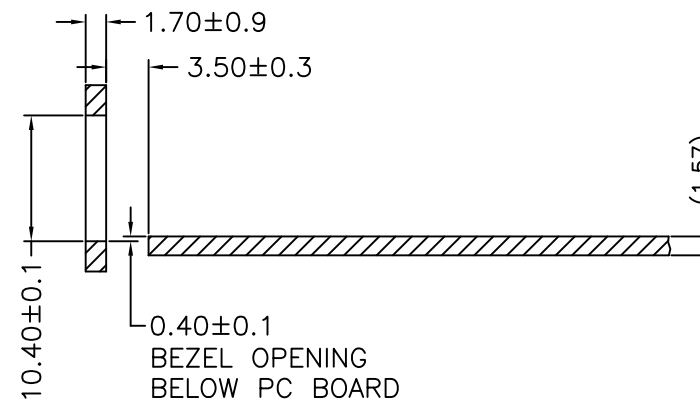
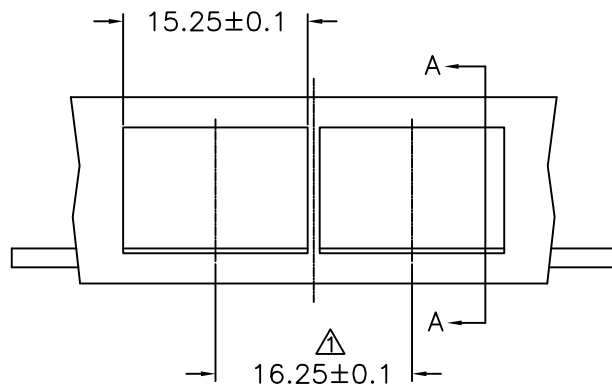
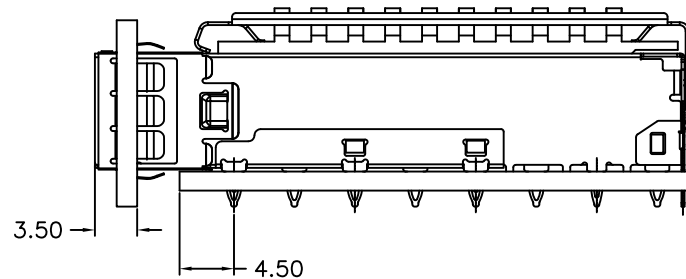

BEZEL OPENING
 BELOW PC BOARD

SECTION A-A

RECOMMENDED BEZEL DESIGN

TITLE SFP+ 1X1 CAGE, WITH HEAT SINK				DELEC		东莞多亚电子有限公司 DONGGUAN DUOYA ELECTRONICS CO., LTD		
PART NO. DH10-2N31220-52N				GENERAL TOLERANCE			UNIT:MM	SIZE: A4
DRAW	Iror	DATE	2018-04-28	.X±0.20	.X±1°	SCALE: 1:1	SHEET:5/6	REV:A
CHECK	Iror	DATE	2018-04-28	.XX±0.15	.XX±5°			
APPROVE	Victor	DATE	2018-04-28	.XXX±0.10				

RoHS COMPLIANT

PACKAGE INFORMATION AND LABEL

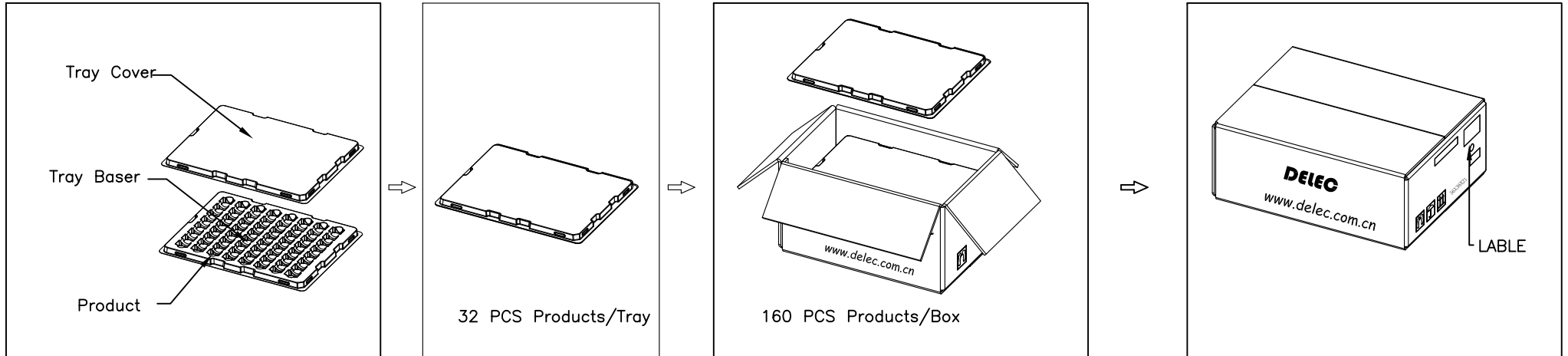

PACKING QUANTITY : 32 PCS FINISHED GOODS PER TRAY

5 TRAYS (160 PCS FINISHED GOODS) PER CARTON BOX

RoHS COMPLIANT

TITLE SFP+ 1X1 CAGE, WITH HEAT SINK				DELEC		东莞多亚电子有限公司 DONGGUAN DUOYA ELECTRONICS CO., LTD		
PART NO. DH10-2N31220-52N				GENERAL TOLERANCE			UNIT:MM	SIZE: A4
DRAW	Iror	DATE	2018-04-28	.X±0.20	.X±1'	SCALE: 1:1	SHEET: 6/6	REV:A
CHECK	Iror	DATE	2018-04-28	.XX±0.15	.XX±5'			
APPROVE	Victor	DATE	2018-04-28	.XXX±0.10				