

Platinum Whistle Digital Servo Drive Installation Guide

**Functional Safety
Safety Capability: F, S, T
EtherCAT and CANopen**

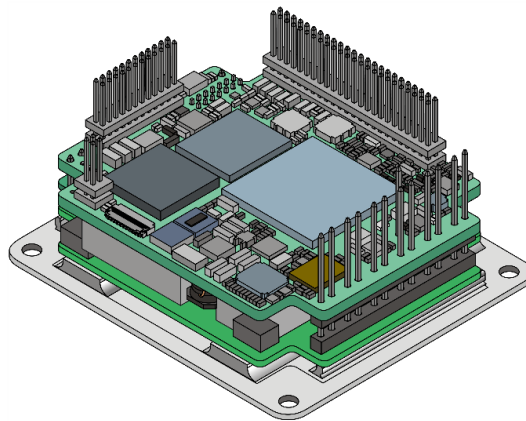
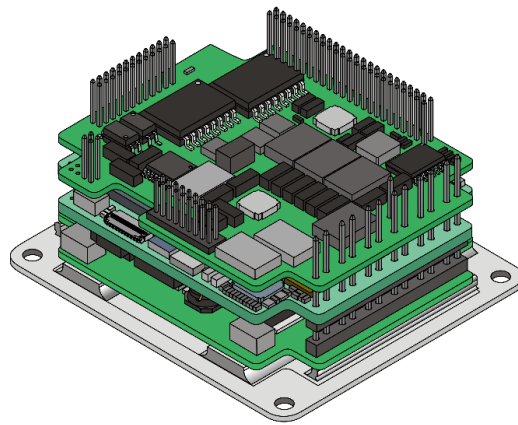

May 2021 (Ver. 2.006)

This guide is delivered subject to the following conditions and restrictions:

- This guide contains proprietary information belonging to Elmo Motion Control Ltd. Such information is supplied solely for the purpose of assisting users of Elmo’s servo drive(s) in their installation.
- The text and graphics included in this manual are for the purpose of illustration and reference only. The specifications on which they are based are subject to change without notice.
- Elmo Motion Control and the Elmo Motion Control logo are trademarks of Elmo Motion Control Ltd.
- Information in this document is subject to change without notice.



Elmo Motion Control and the Elmo Motion Control logo are registered trademarks of Elmo Motion Control Ltd.



EtherCAT® and Safety over EtherCAT® are registered trademarks and patented technologies, licensed by Beckhoff Automation GmbH, Germany.



EtherCAT® Conformance tested is a registered trademark and patented technology, licensed by Beckhoff Automation GmbH, Germany.



CANopen compliant. CANopen® is a registered trademark and patented technology, licensed by CAN in Automation (CiA) GmbH, Kontumazgarten 3, DE-90429 Nuremberg, Germany.

Document no. MAN-P-WHI (Ver. 2.006)

Copyright © 2021

Elmo Motion Control Ltd.

All rights reserved.

Revision History

Version	Date	Version	Date
Ver. 2.000	May 2020	Ver. 2.004	Aug 2020
Ver. 2.001	July 2020	Ver. 2.005	Oct 2020
Ver. 2.002	Aug 2020	Ver. 2.006	May 2021
Ver. 2.003	Aug 2020		

Catalog Number

PWHI-Mz-zXXX/YYYzzzQ

Family Name:
Platinum Whistle

Mounting Version:
M — Board Level Module

Safety Capability :
F — Functional Safety with SafeIO
S — Functional Safety without SafeIO
T — Hardware STO only

Rated Voltage

Rated Continuous Current

Rated Current Mode:
Blank — Standard

Dual Use:
Q — Not subjected to export control according to ECCN-3A225 (US) or 428/2009 - 3A225 (EU Dual Use)

IO Style for Non-SafeIO:
Blank

IO Style for SafeIO:
K — VDD=24V, All Outputs
L — VDD=24V, Outputs 1,2,3,4
VDD=48V, Outputs 7,8
N — VDD=48V, Outputs 7,8

Encoder Port B options:
E — Encoder, Incremental,
Analog Halls, Analog Encoder (SIN/COS)
R — Resolver

Network:
E — EtherCAT or Ethernet
USB
RS-232 Serial Communication
S — CAN (not available at this time)
USB
RS-232 Serial Communication

Chapter 1:	This Installation Guide.....	7
Chapter 2:	Functional Safety.....	7
Chapter 3:	Safety Information	7
3.1	Warnings.....	8
3.2	Cautions.....	8
3.3	CE Marking Conformance	8
3.4	Warranty Information	8
Chapter 4:	Product Description.....	9
Chapter 5:	Technical Information	10
5.1	Physical Specifications	10
5.2	Current/Voltage Technical Data	10
5.3	Control Supply	11
5.4	Encoder Supply.....	11
5.5	Product Features	12
5.5.1	General Product Features	12
5.5.2	Safe IO Features (Safety Capability: F)	12
5.5.3	Regular IO Features (Safety Capability: S and T)	12
5.6	Environmental Conditions	13
5.7	Certifications and Standards.....	14
5.7.1	Dual Use	14
Chapter 6:	Installation	15
6.1	Unpacking the Drive Components.....	15
6.2	Over-Current and Short-Circuit Protection.....	15
6.3	Mounting the Platinum Whistle	16
Chapter 7:	Connections	18
7.1	Motor Power Connector.....	18
7.2	Main Power Connector.....	19
7.3	Control Supply Connector	19
7.4	Connector J1	20
7.5	Connector J2	22
7.6	Connector J4.....	25
7.7	Safe IO Module Connector J5	26
7.8	Drive Status Indicator	26

Chapter 8:	Wiring	27
8.1	Wiring legend	27
8.2	The Platinum Whistle Connection Diagram.....	28
8.2.1	EtherCAT with Safe IO (For Safety Capability F)	28
8.2.2	EtherCAT with Regular IO (Safety Capability: S, T)	29
8.3	Integrating the Platinum Whistle on a PCB	30
8.3.1	Power Returns (PR)	30
8.3.2	COMRET	30
8.3.3	Earth Connection (PE)	30
8.3.4	Power Return (PR), Common Return (COMRET) and Earth Connections (PE)	30
8.4	Power Conductors PCB layout	31
8.5	Motor Power	32
8.6	Main and Control Power.....	33
8.6.1	Control Supply	33
8.6.2	Dual Power Supply for Safety Configuration	34
8.6.3	DC Bus Capacitance	34
8.7	Feedback.....	35
8.7.1	Feedback Port A	35
8.7.1.1	Incremental Encoder	35
8.7.1.2	Absolute Serial Encoder	36
8.7.1.3	Hiperface	36
8.7.2	Feedback Port B	37
8.7.2.1	Incremental Encoder	37
8.7.2.2	Interpolated Analog (Sine/Cosine) Encoder	38
8.7.2.3	Resolver	38
8.7.3	Feedback Port C.....	39
8.7.3.1	Incremental Encoder	39
8.7.3.2	Absolute Serial Encoder	40
8.7.3.3	Emulated Encoder Output	41
8.7.4	Feedback - Hall Sensors.....	41
8.8	Analog Inputs.....	42
8.8.1	Analog Input 1	42
8.9	STO (Safe Torque Off)	42
8.10	Safe Digital I/Os (Safety Capability: F)	43
8.10.1	Digital Input with Test Pulse.....	43
8.10.2	OSSD Digital Input	44
8.10.3	Digital Output	44
8.10.3.1	Option L Configuration VDD_24 & VDD_48.....	44
8.10.3.2	Option K Configuration VDD_24	45
8.10.3.3	Option N Configuration VDD_48	45

8.11	Regular Digital IO	46
8.11.1	Digital Inputs	46
8.11.2	Digital Outputs	46
8.12	Communication	47
8.12.1	RS232 TTL Logic Level	47
8.12.2	USB 2.0	47
8.12.3	EtherCAT/Ethernet	48
8.12.3.1	EtherCAT Status Indicator	48
8.13	CAN (Available within the near future)	49
Chapter 9:	Powering Up.....	50
9.1	Initializing the System.....	50
9.2	Heat Dissipation.....	50
9.2.1	Thermal Data.....	50
9.2.2	Heat Dissipation Data.....	50
9.2.3	How to Use the Charts	51
Chapter 10:	Dimensions	52
10.1	Safe IO Module (PWHI-MF-XXX/YYzzM)	52
10.2	Regular Safe Module (PWHI-MS-XXX/YYzzM) or (PWHI-MT-XXX/YYzzM)	52

Chapter 1: This Installation Guide

This installation Guide details the technical data, pinouts, and power connectivity of the Platinum Whistle.

For a comprehensive specification and detailed description of the functions, refer to the Platinum Safety Drive.

Chapter 2: Functional Safety

The modules of the Platinum Whistle servo drives support Functional Safety. It is necessary to implement the instructions in the [Platinum Safety Drive Manual](#) regarding using STO, Feedbacks, IOs and Power supplies with Functional Safety.

Chapter 3: Safety Information

In order to achieve the optimum, safe operation of the Platinum Whistle, it is imperative that you implement the safety procedures included in this installation guide. This information is provided to protect you and to keep your work area safe when operating the Platinum Whistle and accompanying equipment.

Please read this chapter carefully before you begin the installation process.

Before you start, ensure that all system components are connected to earth ground. Electrical safety is provided through a low-resistance earth connection.

Only qualified personnel may install, adjust, maintain and repair the servo drive. A qualified person has the knowledge and authorization to perform tasks such as transporting, assembling, installing, commissioning and operating motors.

The Platinum Whistle contains electrostatic-sensitive components that can be damaged if handled incorrectly. To prevent any electrostatic damage, avoid contact with highly insulating materials, such as plastic film and synthetic fabrics. Place the product on a conductive surface and ground yourself in order to discharge any possible static electricity build-up.

To avoid any potential hazards that may cause severe personal injury or damage to the product during operation, keep all covers and cabinet doors shut.

The following safety symbols are used in this and all Elmo Motion Control manuals:



Warning:

This information is needed to avoid a safety hazard, which might cause bodily injury or death as a result of incorrect operation.



Hot Surface Warning:

To alert against surfaces that may reach high temperatures. The heatsink and wires may reach high temperatures.



Caution:

This information is necessary to prevent bodily injury, damage to the product or to other equipment.



Important:

Identifies information that is critical for successful application and understanding of the product.

The following symbols are used in this document:



Note: Information critical to the understanding and/or operating the feature.



Tip: Information that helps understanding a feature, is good practice or a possible different way of action.

3.1 Warnings

- To avoid electric arcing and hazards to personnel and electrical contacts, never connect/disconnect the servo drive while the power source is on.
- Power cables can carry a high voltage, even when the motor is not in motion. Disconnect the Platinum Whistle from all voltage sources before servicing.
- The high voltage products within the Platinum Line range contain grounding conduits for electric current protection. Any disruption to these conduits may cause the instrument to become hot (live) and dangerous.
- All connectors except STO operating at voltage greater than ELV, require an isolation for working voltage 170VDC.



Capacitance Discharge

After shutting off the power and removing the power source from your equipment, wait at least 10 seconds before touching or disconnecting parts of the equipment that are normally loaded with electrical charges (such as capacitors or contacts). Measuring the electrical contact points with a meter, before touching the equipment, is recommended.

3.2 Cautions

- The maximum DC power source connected to the instrument must comply with the parameters outlined in this guide.
- When connecting the Platinum Whistle to an approved control supply, connect it through a line that is separated from hazardous live voltages using reinforced or double insulation in accordance with approved safety standards.
- Before switching on the Platinum Whistle, verify that all safety precautions have been observed and that the installation procedures in this manual have been followed.
- Make sure that the Safe Torque Off is operational

3.3 CE Marking Conformance

The Platinum Whistle is intended for incorporation in a machine or end product. The actual end product must comply with all safety aspects of the relevant requirements of the European Safety of Machinery Directive 2006/42/EC as amended, and with those of the most recent versions of standards EN 60204-1 and EN ISO 12100 at the least, and in accordance with 2006/95/EC.

Concerning electrical equipment designed for use within certain voltage limits, the Platinum Whistle meets the provisions outlined in 2006/95/EC. The party responsible for ensuring that the equipment meets the limits required by EMC regulations is the manufacturer of the end product.

3.4 Warranty Information

The products covered in this manual are warranted to be free of defects in material and workmanship and conform to the specifications stated either within this document or in the product catalog description. All Elmo drives are warranted for a period of 12 months from the date of shipment. No other warranties, expressed or implied — and including a warranty of merchantability and fitness for a particular purpose — extend beyond this warranty.

Chapter 4: Product Description

The Platinum Whistle is an advanced high power density servo drive, delivering up to **1.6 kW of continuous power** or **3.2 kW of peak power** in a 50.77 cc (3.10 in³) package (55 x 46.5 x 19.9 mm (2.17" x 1.83" x 0.78")). The Platinum Whistle is designed to be mounted on a PCB by soldering its pins directly to the PCB.

This advanced, high power density servo drive provides top performance, Functional Safety, advanced networking as well as a fully featured motion controller and local intelligence.

The Platinum Whistle is provided in three safety configurations:

- **Functional Safety with Safe IO (PWHI-MF):** Servo drive with Function Safety and Safe IO – This configuration of Servo drives includes safe Digital IO which support Safe Digital Inputs and Outputs including Brakes. This configuration supports the operation of the safety function either via FSOE or via the Safe I/O.
- **Functional Safety without Safe IO (PWHI-MS):** Servo drive with Function Safety excluding Safe IO – This configuration of Servo drives includes regular Digital IO. This configuration permits operation of safety functions only via FSOE (Fail Safe Over EtherCAT).
- **STO Only (PWHI-MT):** Servo drive with STO – The servo drive supports only STO



Important:

For functional safety the integration board must be designed and approved according to the safety standards IEC61800-5-2.

The Platinum Whistle is powered by dual isolated power supplies from the Main, main DC power 10 V to 195 V and a Control power supply for the logic.

The drive can operate as a stand-alone device or as part of a multi-axis system in a distributed configuration on a real-time network.

The Platinum Whistle drive is easily set up and tuned using the Elmo Application Studio (EASII) software tools. As part of the Platinum product line, it is fully programmable with the Elmo motion control language. For more information about software tools refer to the Elmo Application Studio (EASII) User Guide.

Chapter 5: Technical Information

5.1 Physical Specifications

Feature	Units	All Types
Weight	g (oz)	~55 g (1.94 oz)
Weight with SafelO Board	g (oz)	~65 g (2.29 oz)
Dimensions	mm (in)	55 x 46.5 x 19.9 mm (2.2" x 1.83" x 0.78")
Dimension with SafelO Board	mm (in)	55 x 46.5 x 23.2 mm (2.2" x 1.83" x 0.91")
Mounting method		PCB mount
Degrees of Protection		IP00

5.2 Current/Voltage Technical Data

Feature	Units	1/100	2.5/100	5/100	10/100	15/100	20/100	25/100
Minimum supply voltage	VDC	10						
Nominal supply voltage	VDC	85						
Maximum supply voltage	VDC	95						
Maximum continuous power output	W	80	200	400	800	1200	1600	2000
Efficiency at rated power (at nominal conditions)	%	> 99						
Maximum output voltage		> 95% of DC bus voltage at f = 22 kHz						
Control supply	VDC	12 to 60V for functional safety (up to 6 VA inc. 5 V/2 x 200 mA for Encoder)						
Amplitude sinusoidal/DC continuous current	A	1.0	2.5	5	10	15	20	25
Sinusoidal continuous RMS current limit (Ic)	A	0.7	1.8	3.5	7	10.6	14.1	17.5
Peak current limit	A	2 x Ic						

Table 1: Technical Data



Note (on current ratings):

The current ratings of the Platinum Whistle are given in units of DC amperes (ratings that are used for trapezoidal commutation or DC motors). The RMS (sinusoidal commutation) value is the DC value divided by 1.41.

Elmo offers a 200 VDC maximum output rating selection of Platinum Whistle, according to the following technical data:

Feature	Units	3/200	6/200	9/200
Minimum supply voltage	VDC	20		
Nominal supply voltage	VDC	170		
Maximum supply voltage	VDC	195		
Maximum continuous power output	W	480	960	1450
Efficiency at rated power (at nominal conditions)	%	> 99		
Maximum output voltage		> 95% of DC bus voltage at f = 22 kHz		
Control supply	VDC	12 to 60V for functional safety (up to 6 VA inc. 5 V/2 x 200 mA for Encoder)		
Amplitude sinusoidal/DC continuous current	A	3	6	9
Sinusoidal continuous RMS current limit (Ic)	A	2.1	4.2	6.3
Peak current limit	A	2 x Ic		

5.3 Control Supply

Feature	Details
Control supply input voltage	Isolated DC source: 12 to 60V
Control supply input power	≤4 VA without external loading ≤6 VA with full external loading

5.4 Encoder Supply

Feature	Details
5V supply	5V Nominal, 4.75V÷5.25V up to 400mA
11V supply only with SafeIO Module	11V Nominal, 10.6V÷11.5V up to 300mA

5.5 Product Features

5.5.1 General Product Features

Main Feature	Details	Presence and No.	
Feedback	Standard Port A, B, & C	√	
Communication Option	USB	√	
	EtherCAT	√	
	CAN (Available in the future)	√	Applicable only for Safety capability T
	RS-232 TTL level	√	
Analog Input	Differential ±10V	1	

5.5.2 Safe IO Features (Safety Capability: F)

Main Feature	Details	Presence and No.
STO	PLC Source	√
Digital Input	PLC Source	4
Safe Digital Output	PLC Source	3
	PLC Sink	1
Regular Digital Output	PLC Source	2

5.5.3 Regular IO Features (Safety Capability: S and T)

Main Feature	Details	Presence and No.
STO	TTL (isolated)	√
Digital Input	TTL 3.3V (Non Isolation)	6
Digital Output	TTL 3.3V (Non Isolation)	4

5.6 Environmental Conditions

You can guarantee the safe operation of the Platinum Whistle by ensuring that it is installed in an appropriate environment.

Feature	Details
Operating ambient temperature according to IEC60068-2-2	0 °C to 55 °C (32 °F to 131 °F)  Remark: Functional Safety is applicable to the above operating temperature. In some products, power derating is required to operate above 50°C.
Storage temperature	-20 °C to +85 °C (-4 °F to +185 °F)
Maximum non-condensing humidity according to IEC60068-2-78	95%
Maximum Operating Altitude	2,000 m (6562 feet) It should be noted that servo drives capable of higher operating altitudes are available on request.
Mechanical Shock according to IEC60068-2-27	15g / 11ms Half Sine
Vibration according to IEC60068-2-6	5 Hz ≤ f ≤ 10 Hz: ±10mm 10 Hz ≤ f ≤ 57 Hz: 4G 57 Hz ≤ f ≤ 500 Hz:5G
Pollution Degree	Pollution Degree 1

5.7 Certifications and Standards

The following table describes the Main Standards of the Platinum Whistle servo drive. For further details, refer to Chapter 22 in the [Platinum Safety Drive Manual](#).

Main Standards	Item
The related standards below apply to the performance of the servo drives as stated in section 5.6 Environmental Conditions above.	
IEC 61800-5-2:2016	Adjustable speed electrical power drive systems – Safety requirements – Functional
EN ISO 13849-1:2015	Safety of machinery — Safety-related parts of control systems.
IEC/EN 61800-5-1	Adjustable speed electrical power drive systems Safety requirements – Electrical, thermal and energy
IEC 61508	Functional Safety of Electrical/Electronic/Programmable Electronic Safety-related Systems (E/E/PE, or E/E/PES)
In compliance with UL61800-5-1	Adjustable speed electrical power drive systems Safety requirements – Electrical, thermal and energy
In compliance with CSA C22.2 NO. 274	Industrial Control Equipment
Conformity with CE 2006/95/EC	Low-voltage directive 2006/95/EC

5.7.1 Dual Use

No export license is required for the Platinum Line products signified with the suffix Q in the Part Number.

The operating frequency of the Platinum Line products is “factory limited” to ≤ 599 Hz, and therefore complies with the EU Dual Use Regulation 428/2009, 3A225, and the US Dual Use regulation EAR ECCN# 3A225.

This statement applies to all identical specimens and will become invalid if a change is made in the firmware.

Chapter 6: Installation

The Platinum Whistle must be installed in a suitable environment and properly connected to its voltage supplies and the motor.

6.1 Unpacking the Drive Components

Before you begin working with the Platinum Whistle, verify that you have all of its components, as follows:

- The Platinum Whistle servo drive
- The Elmo Application Studio (EASII) software

The Platinum Whistle is shipped in a cardboard box with Styrofoam protection.

To unpack the Platinum Whistle:

1. Carefully remove the servo drive from the box and the Styrofoam.
2. Check the drive to ensure that there is no visible damage to the instrument. If any damage has occurred, report it immediately to the carrier that delivered your drive.
3. To ensure that the Platinum Whistle you have unpacked is the appropriate type for your requirements, locate the part number sticker on the side of the Platinum Whistle. It looks like this:



4. Verify that the Platinum Whistle type is the one that you ordered, and ensure that the voltage meets your specific requirements.
The part number at the top provides the type designation. Refer to the appropriate part number in the section Catalog Number at the beginning of the installation guide.

6.2 Over-Current and Short-Circuit Protection

A serial fuse or circuit breaker should be installed Rated for drive's continuous current rating.

PWHI- <i>zz-zXXX/YYYzzz-z</i> XXX = rated continues current [A]	Fuse	Circuit Breaker
1, 2.5, 5, 10, 15, 20, 25 / 100v	Fast Acting	Type B
3, 6, 9, 10 / 200v	Fast Acting	
Rated short - circuit breaking capacity 5kA		

PL/CL protection: Peak and Continues Limitation

The peak current of servo drive limit for a given application is programmed to the parameter **PL[1]** amperes.

PL[1]: Value for peak current limit protection. Please refer to the "Platinum Administrative Guide".

6.3 Mounting the Platinum Whistle

The Platinum Whistle was designed for mounting on a printed circuit board (PCB) via 1.27 mm pitch 0.6 mm square pins and 2 mm pitch 0.9 mm square pins. When integrating the Platinum Whistle into a device, be sure to leave about 1 cm (0.4") outward from the heat-sink to enable free air convection around the drive. We recommend that the Platinum Whistle be soldered directly to the board. Alternatively, though this is not recommended, the Platinum Whistle can be attached to socket connectors mounted on the PCB. If the PCB is enclosed in a metal chassis, we recommend that the Platinum Whistle be screw-mounted to it as well to help with heat dissipation. The Platinum Whistle has screw-mount holes on each corner of the heat-sink for this purpose – see below.

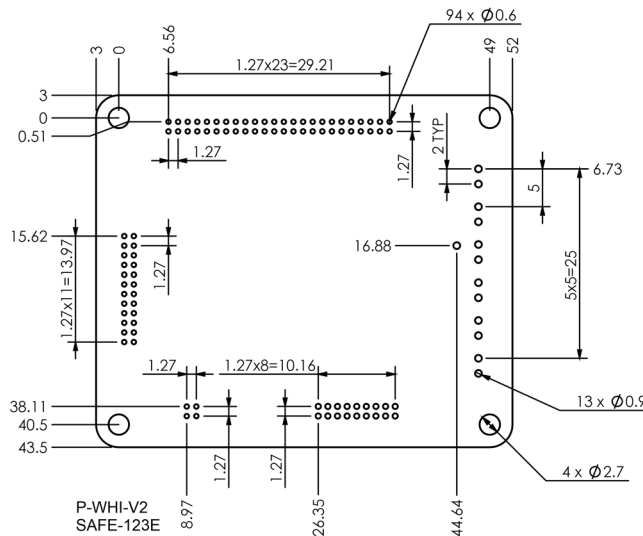

Figure 1: Platinum Whistle Dimensions with Safe IO Module - All measurements are in mm

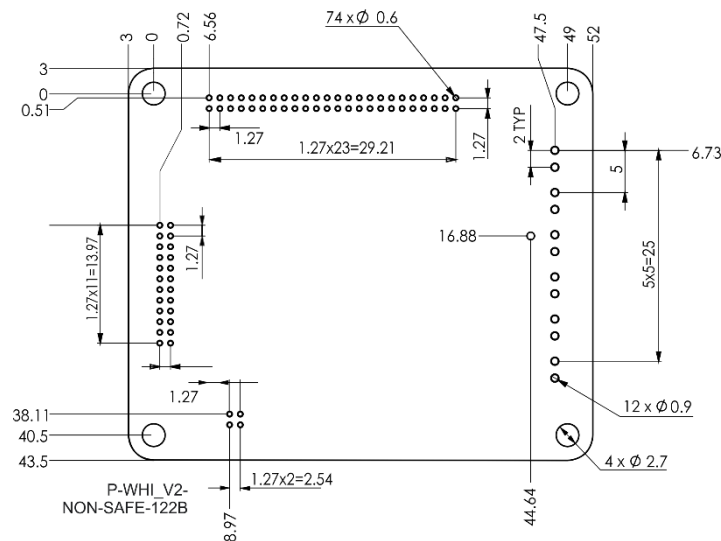
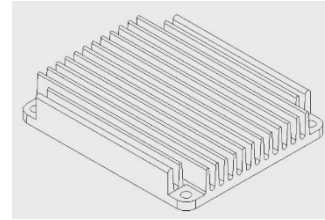

Figure 2: Platinum Whistle Dimensions - All measurements are in mm

When the Platinum Whistle is not connected to a metal chassis, the application's thermal profile may require a solution for heat dissipation due to insufficient air convection. In this case, we recommend that you connect an external heat sink. Elmo has an external heat sink (Catalog number: WHI-HEATSINK-2) that can be ordered for this purpose (see figure at side).



Chapter 7: Connections

The Platinum Whistle has ten connectors, and with the additional Safe IO Module, eleven connectors.

Port	Pins	Type	Function	Connector Location
J4	2x2	1.27 mm pitch 0.41 mm sq	STO	<p>P-WHI_V2-NON-SAFE-077A</p>
J2	2x24		Feedbacks, Digital Halls, Analog Inputs, Communications	
J1	2x12		Regular Digital I/O, LEDs	
M3	1x2		Motor power output 3	
M2	1x2	Motor power output 2		
M1	1x2	Motor power output 1		
PE	1x2	Protective earth		
PR	1x2	Power input return		
VP+	1x2	Positive power input		
VL+	1x1	Control power input		
J5	2x9	1.27 mm pitch 0.41 mm sq	Safe Digital IO	

Table 2: Connector Types

7.1 Motor Power Connector

For full details see section 16.3 in the [Platinum Safety Drive Manual](#).

Pin	Function	Cable		Pin Positions
		Brushless Motor	Brushed DC Motor	
PE	Protective earth	Motor	Motor	 <p>P-WHI_V2-NON-SAFE-779A</p>
M1	Motor phase	Motor	Not Connected	
M2	Motor phase	Motor	Motor	
M3	Motor phase	Motor	Motor	
Connector Type: 2 mm pitch 0.51 mm sq				

Table 3: Motor Connector

7.2 Main Power Connector

Pin	Function	Cable	Pin Positions
VP+	Positive Power input	DC Power	 <p>P-WHI_V2-NON-SAFE-880A</p>
PR	Power return	DC Power	
PE	Protective earth	DC Power	
Connector Type: 2 mm pitch 0.51 mm sq			

Table 4: Connector for Main Power

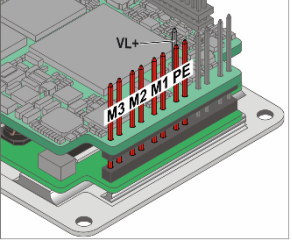
7.3 Control Supply Connector

Pin	Function	Pin Positions
VL+	Control Supply Input	 <p>P-WHI_V2-NON-SAFE-881A</p>
PR	Control Supply Return	
Connector Type: 2 mm pitch 0.51 mm sq		

Table 5: Control Supply Pins

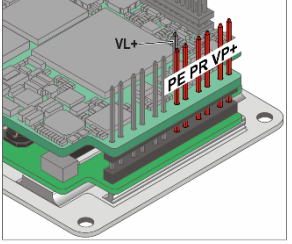
7.4 Connector J1

The connector J1 can either be utilized without the Safe IO module, or in conjunction with the Safe IO module, and consists of the following:

- Regular Digital I/Os
- LEDs

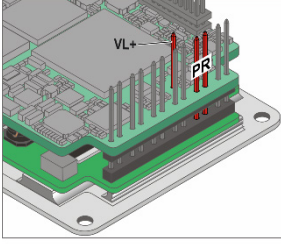
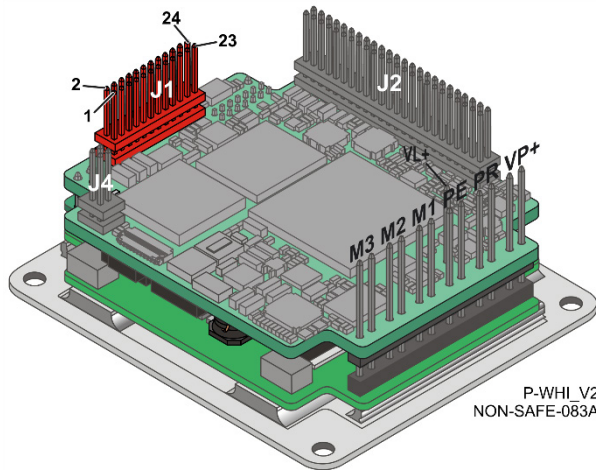

Platinum Whistle Connector J1

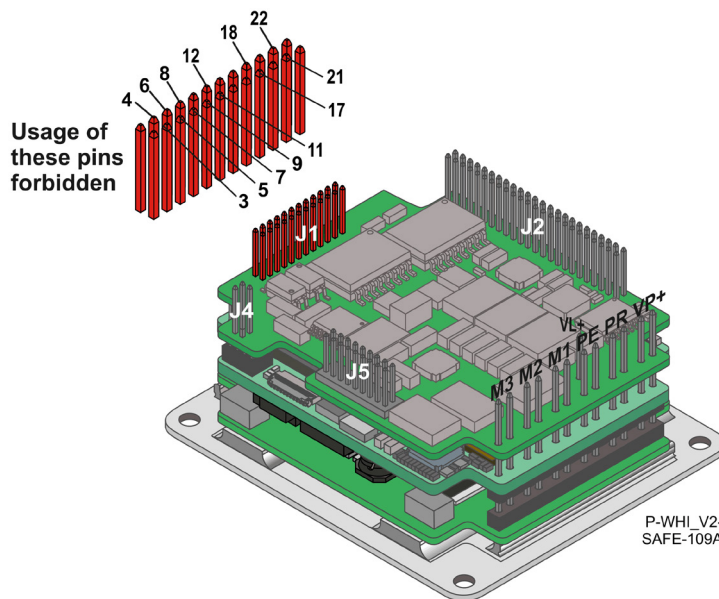

Platinum Whistle with Safe IO module Connector J1

For full details on Digital and Analog I/Os, see sections 16.7 and 16.8 in the [Platinum Safety Drive Manual](#).

For full details on the LEDs, see 16.4 Drive Status Indicator, and section 16.10.2.4 EtherCAT Status Indicator in the [Platinum Safety Drive Manual](#). for details.

For full details on STO, see section 16.5 in the [Platinum Safety Drive Manual](#). for details.

Connector Type: 1.27 mm pitch
0.41 mm sq

Pin (J1)	Signal	Function without Safe IO Regular IO: Safety capability: S, T	Function with Safe IO Safe IO : Safety capability: F
1	SB_Load	Serial Bus Load for extended IO (refer to section 16.9 of the MAN-P Safety Drive Manual)	
2	SB_Clock	Serial Bus_Clock (9.375Mhz) for extended IO (refer to section 16.9 of the MAN-P Safety Drive Manual)	
3	IN2	Digital input 2 (3.3V TTL level)	Reserved

Pin (J1)	Signal	Function without Safe IO Regular IO: Safety capability: S, T	Function with Safe IO Safe IO : Safety capability: F
4	IN1	Digital input 1 (3.3V TTL level)	Reserved
5	IN4	Digital input 4 (3.3V TTL level)	Reserved
6	IN3	Digital input 3 (3.3V TTL level)	Reserved
7	IN6	Digital input 6 (3.3V TTL level)	Reserved
8	IN5	Digital input 5 (3.3V TTL level)	Reserved
9	Not in use		
10	Not in use		
11	OUT8	Output 8 (3.3V TTL level)	Reserved
12	OUT7	Output 7 (3.3V TTL level)	Reserved
13	LED_ETHERCAT ERR	LED Status EtherCAT ERR	
14	LED_ETHERCAT RUN	LED Status EtherCAT RUN	
15	Not in use		
16	Not in use		
17	OUT2	Output 2 (3.3V TTL level)	Reserved
18	OUT1	Output 1 (3.3V TTL level)	Reserved
19	LED2	Bi-color indication output 2 (Cathode)	
20	LED1	Bi-color indication output 1 (Cathode)	
21	Not in use		
22	Not in use		
23	COMRET	Common return	
24	+11V	+11V supply voltage	

Table 6: Connector J1 Pinouts – I/O, LEDs

7.5 Connector J2

The J2 connector consists of the following:

- Feedback
- Analog Inputs
- RS-232
- USB
- EtherCAT, Ethernet
- CAN

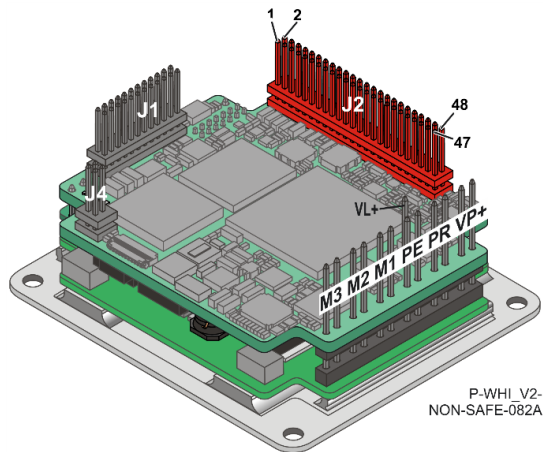

Feedback A/B/C, Digital Halls – see section 16.6: Feedback in the [Platinum Safety Drive Manual](#)..

Analog Inputs - For full details on Analog Inputs see section 16.8 Analog Input in the [Platinum Safety Drive Manual](#)..

RS-232 – For full details on RS-232 see section 16.10.3 in the [Platinum Safety Drive Manual](#)..

USB 2.0 – For full details on USB see section 16.10.1 in the [Platinum Safety Drive Manual](#)..

EtherCAT/Ethernet – For full details on EtherCAT/Ethernet see section 16.10.2 in the [Platinum Safety Drive Manual](#)..

CAN – For full details on CAN see section 4.10 in the [Platinum Safety Drive Manual](#)..

Connector Type: 1.27 mm pitch 0.41 mm sq

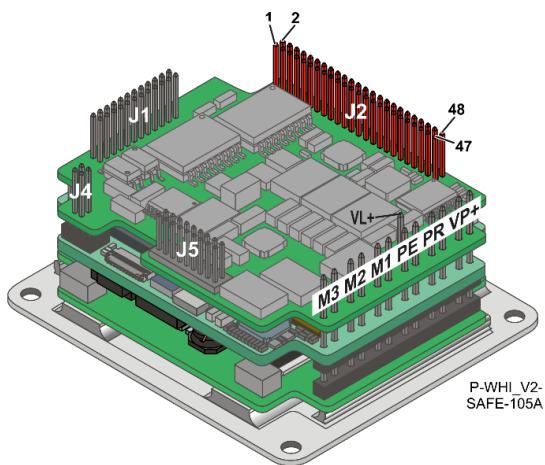

Note (regarding the EtherCAT and CAN communication option):

The J2 Connector exports all supported communication links. However, note that CAN and EtherCAT are not available in the same version of the Platinum Whistle and are thus not operational simultaneously. See the catalog number diagram **Catalog Number** above for the different Platinum Whistle configurations.

Pin (J2)	Signal	Function
1	PortA_A+	Port A- channel A+
2	PortC_A-	Port C- channel A-

Pin (J2)	Signal	Function
3	PortA_A-	Port A- channel A-
4	PortC_A+	Port C- channel A+
5	PortA_B+	Port A - channel B+
6	PortC_B-	Port C - channel B-
7	PortA_B-	Port A - channel B-
8	PortC_B+	Port C - channel B+
9	PortA_INDEX+	Port A – Channel_Index+
10	PortC_INDEX-	Port C - Channel_Index-
11	PortA_INDEX-	Port A - Channel_Index-
12	PortC_INDEX+	Port C -Channel_Index+
13	PortB_A+	Port B - channel A+
14	HC	Hall sensor C input
15	PortB_A-	Port B - channel A-
16	HB	Hall sensor B input
17	PortB_B+	Port B - channel B+
18	HA	Hall sensor A input
19	PortB_B-	Port B - channel B-
20	ANALOG_IN2	Analog Input 2
21	PortB_INDEX+	Port B - Channel_Index+
22	ANALOG1+	Analog input 1
23	PortB_INDEX-	Port B – Channel_Index-
24	ANALOG1-	Analog input 1 complement
25	COMRET	Common return
26	+3.3V	3.3 V supply voltage
27	PHY_IN_RX+	EtherCAT In receive
28	PHY_OUT_RX+	EtherCAT Out receive
29	PHY_IN_RX-	EtherCAT In receive complement
30	PHY_OUT_RX-	EtherCAT Out receive complement
31	COMRET	Common return
32	COMRET	Common return

Pin (J2)	Signal	Function
33	PHY_IN_TX+	EtherCAT In transmit
34	PHY_OUT_TX+	EtherCAT Out transmit
35	PHY_IN_TX-	EtherCAT In transmit complement
36	PHY_OUT_TX-	EtherCAT Out transmit complement
37	EtherCAT: PHY_IN_LINK_ACT	EtherCAT In active LED
	CAN: CAN_L	CAN_L BUS Line(dominant low)
38	EtherCAT: PHY_OUT_LINK_ACT	EtherCAT Out active LED
39	CAN: CAN_H	CAN_H BUS Line(dominant high)
40	Not in use	
41	USB D-	USB_N line
42	USB D+	USB_P line
43	Not in use	
44	USB_VBUS	USB VBUS 5V
45	RS232_RX /SB_OUT	There are two options for this pin: Option 1: RS232 receive (default) Option 2: Serial Bus output for extended I/O (refer to section 16.9 of the MAN-P Safety Drive Manual)
46	RS232_TX /SB_IN	There are two options for this pin: Option 1: RS232 transmit (Default) Option 2: Serial Bus IN for extended I/O (refer to section 16.9 of the MAN-P Safety Drive Manual)
47	+5VE	Encoder +5 V supply
48	COMRET	Common return

Table 7: Connector J2 Pinouts – Feedback and Analog Input

7.6 Connector J4

The J4 connector consists of the following:

- STO

Connector Type: 1.27 mm pitch
0.41 mm sq

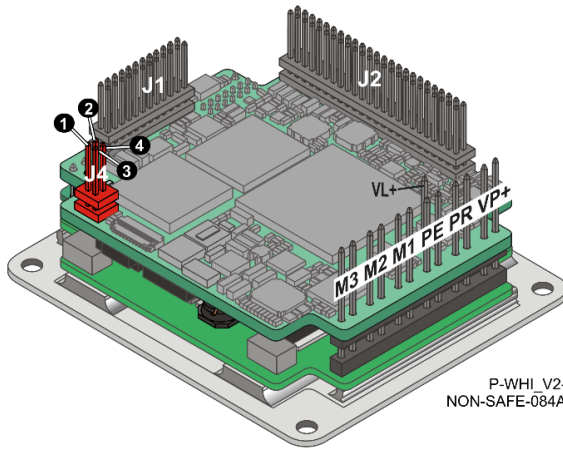

Platinum Whistle Connector J4

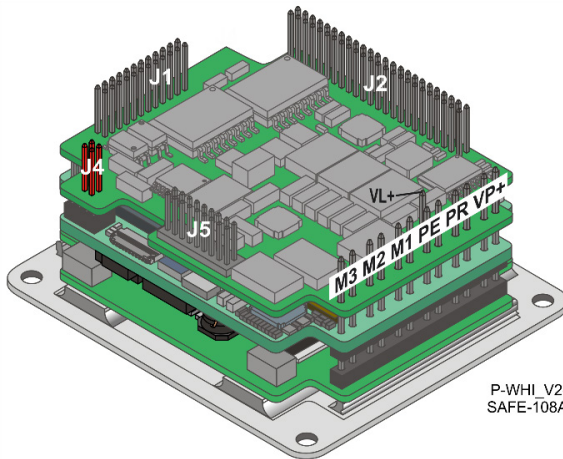

Platinum Whistle with Safe IO module Connector J4

Pin (J4)	Signal	Function
1	STO_RET	STO signal return
2	STO_RET	STO signal return
3	STO1	STO 1 input
4	STO2	STO 2 input

7.7 Safe IO Module Connector J5

The J5 connector consists of the following:

- Digital Outputs/ Inputs
- VDD

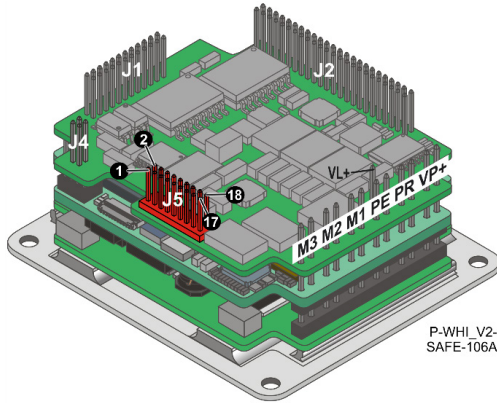

Connector Type:

1.27 mm pitch

0.41 mm sq

Refer to sections 16.7.2 and 16.7.3 Digital Inputs/Outputs in the [Platinum Safety Drive Manual](#). in order to implement the IOs

Pin (J5)	Signal	Function
1	IN1	PLC Source, Safe digital input 1
2	IN3	PLC Source Safe digital input 3
3	IN2	PLC Source Safe digital input 2
4	IN4	PLC Source Safe digital input 4
5	OUT8	Safe OUT8 - PLC SINK
6	OUT7	Safe OUT7 - PLC Source
7	VDD 48V	Supply, VDD Power
8	VDD 48V	
9	VDD RET	
10	VDD RET	
11	VDD RET	VDD Return
12	VDD RET	
13	VDD 24V	
14	VDD 24V	
15	OUT2	OUT2 - PLC Source, can be used for Test_pulse2 or Non-Safe OUT2
16	OUT4	OUT4 - PLC Source can be for Safe OUT, Test_pulse4 or Non-Safe OUT4
17	OUT1	OUT1 - PLC Source, can be used for Test_pulse1 or Non-Safe OUT1
18	OUT3	OUT3 - PLC Source can be for Safe OUT, Test_pulse3 or Non-Safe OUT3

Table 8: Connector J5 Pinouts

7.8 Drive Status Indicator





For details of the Drive Status Indicator wiring, refer to section 16.4 in the [Platinum Safety Drive Manual](#).

Chapter 8: Wiring

8.1 Wiring legend

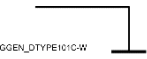
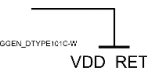
Once the product is mounted, you are ready to wire the device. Proper wiring, grounding and shielding are essential for ensuring safe, immune and optimal servo performance of the drive.

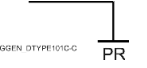
The following table legend describes the wiring symbols detailed in all installation guides.

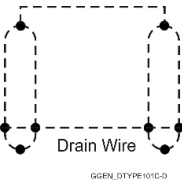
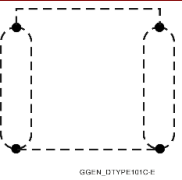
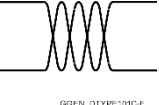
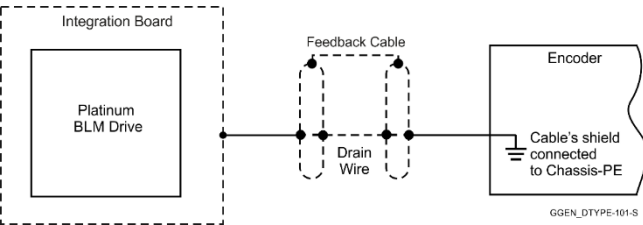
Wiring Symbol	Description
	Earth connection (PE)
	User Side: This symbol signifies that any type of grounding may be used on the user side
	VDD Return
	Isolated Ground
	Power Return
	COMRET Common at the Drive
	Shielded cable with drain wire. The drain wire is a non-insulated wire that is in direct contact with the braid (shielding). Shielded cable with drain wire significantly simplifies the wiring and earthing.
	Shielded cable braid only, without drain wire.
	Twisted-pair wires
	Encoder Earthing. The cable's shield is connected to the chassis (PE) in the connector. The servo drive shield is connected to Earth.

8.2 The Platinum Whistle Connection Diagram

8.2.1 EtherCAT with Safe IO (For Safety Capability F)

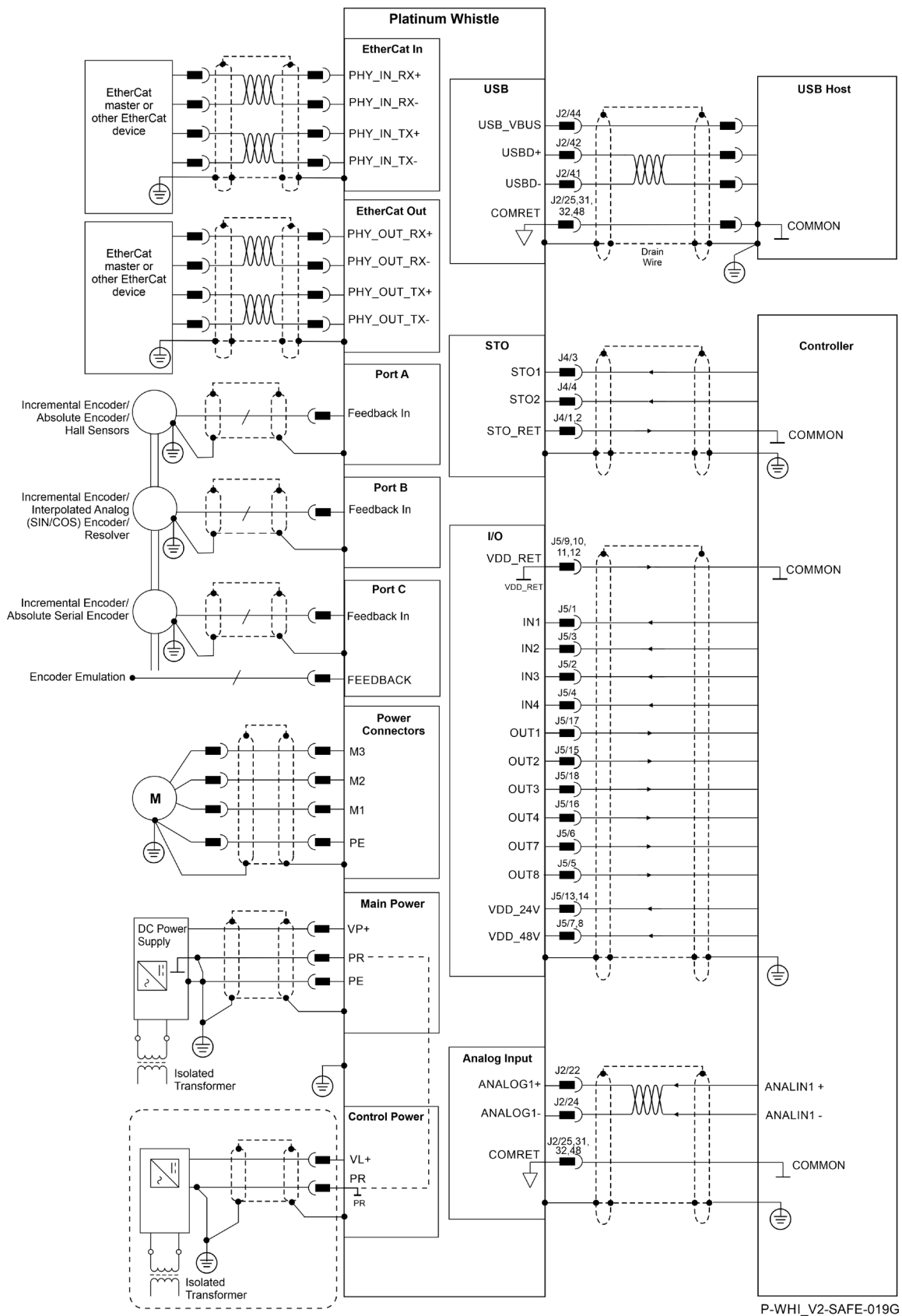

Figure 3: The Platinum Whistle with Safe IO Connection Diagram

8.2.2 EtherCAT with Regular IO (Safety Capability: S, T)

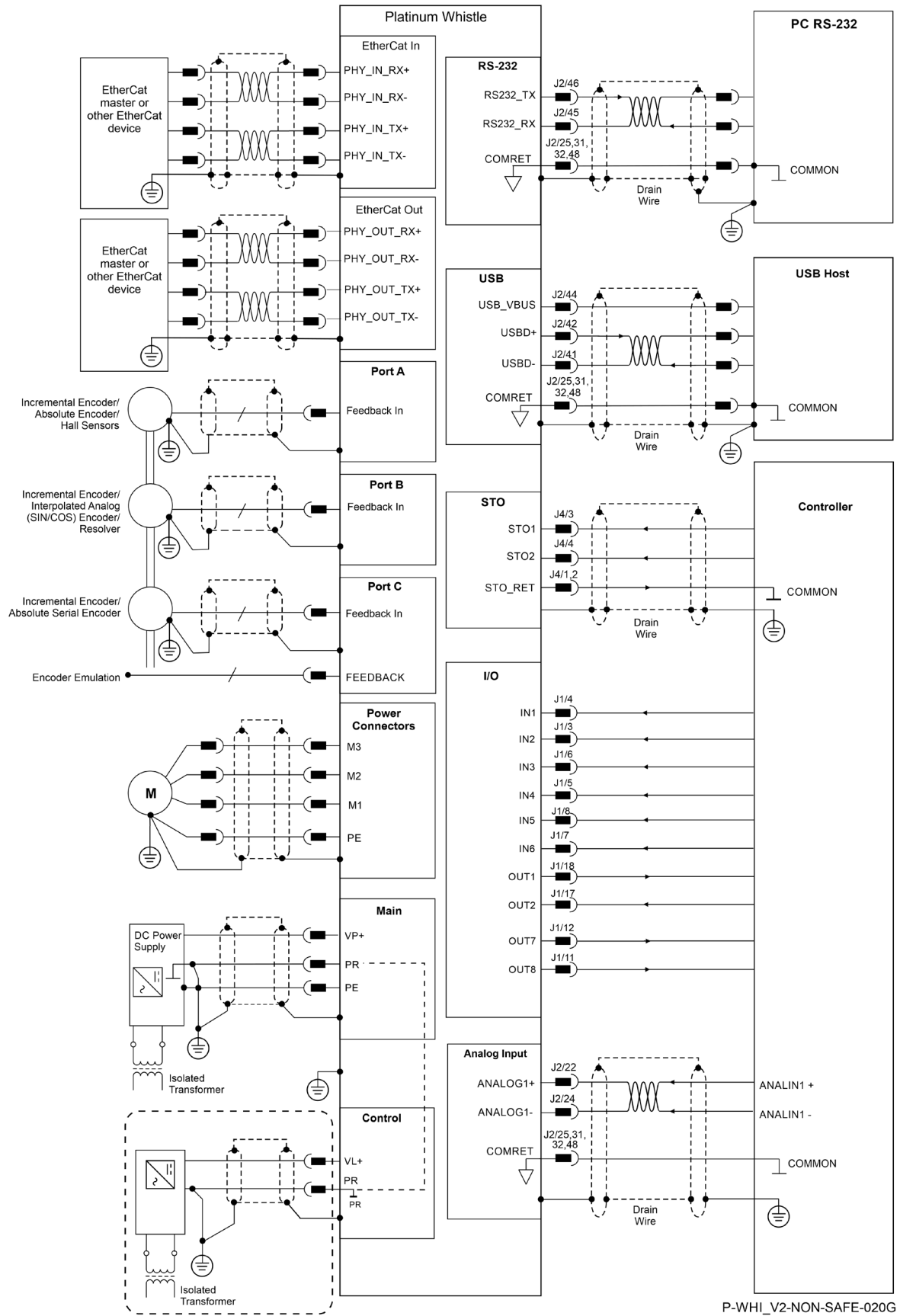

Figure 4: The Platinum Whistle Connection Diagram

8.3 Integrating the Platinum Whistle on a PCB

The Platinum Whistle is designed to be mounted on a PCB by soldering its pins directly to the PCB. Refer to Chapter 16 in the [Platinum Safety Drive Manual](#). for further information.

8.3.1 Power Returns (PR)

In the Platinum Whistle, the power stage and control stage are internally connected, and the negative node of the DC power bus is designated as PR.

The maximum realistic Power Return is achieved using a plane, which connects between the Platinum Drive and the power source. The impedance on this plane must be as low as possible to reduce the impedance between the “Grounds”. This effectively reduces the levels of common mode differences, interferences, EMI, etc.

8.3.2 COMRET

For details of the COMRET, refer to section 16.1.4 in the [Platinum Safety Drive Manual](#).

8.3.3 Earth Connection (PE)

The PE (Earth connection) terminal is connected internally in the drive to the Platinum Whistle’s chassis (heat-sink + metal cover) which serves as an EMI common plane. Any other assembly metallic parts (such as the chassis) should also be connected to the PE.

Under normal operating conditions, the PE trace carries no current. The only time these traces carry current is under unusual conditions (such as when the device has become a potential shock or fire hazard while conducting external EMI interferences directly to ground). When connected properly the PE trace prevents these hazards from affecting the drive.

8.3.4 Power Return (PR), Common Return (COMRET) and Earth Connections (PE)

Safety regulations (UL61800-5-1, IEC61800-5-1, and UL508C) require that the servo drive, as a “stand alone”, must withstand breakdown voltages of 2KV for the 200V models, and 1.7KV for the 100V models, between PE to PR. However, the connections between PE to PR and the COMRET are essential for the safe operation of the servo drive. Therefore the following topology must be used:

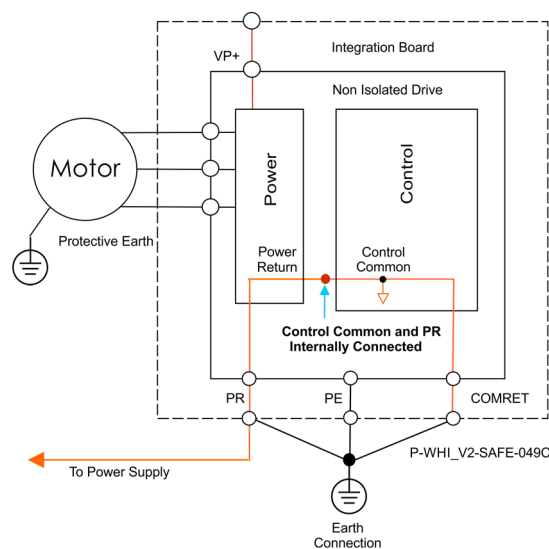

Figure 5: Platinum Whistle Earth Connections

The connections to PE are essential but must be done externally to the integration board. The COMRET should be connected to the PR in the Integration Board.

8.4 Power Conductors PCB layout

The PCB is virtually divided into two zones; Power Zone, and Control & Communication Zone.

- Power Zone**
 This area is dedicated to Power conductors only: VP+, PR, PE, VL+, and motor leads.
- Control and Communication Zone**
 This area of the PCB is dedicated to Control low level signals

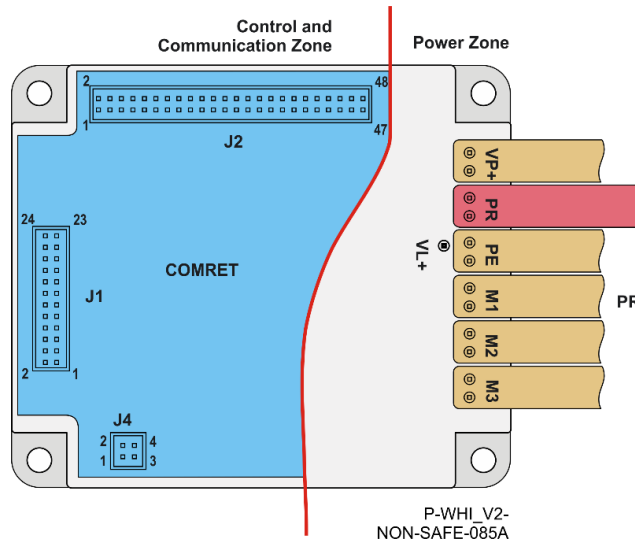

Figure 6: Platinum Whistle Power Conductors PCB layout

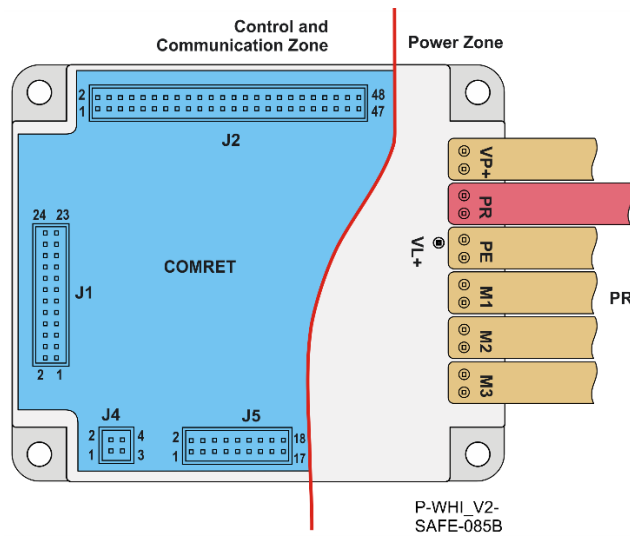

Figure 7: Platinum Whistle Power Conductors PCB layout with Safe IO Module

For more details, refer to section 16.2 in the [Platinum Safety Drive Manual](#).

8.5 Motor Power

When connecting several drives to several similar motors, all should be wired in an identical manner. This will enable the same settings to run on all drives.

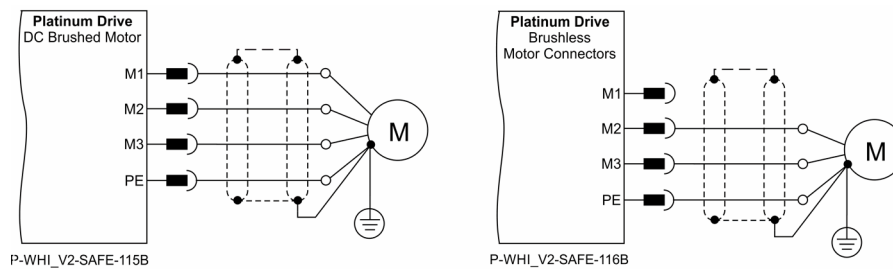

Figure 8: Brushless and Brushed Motor Power Connection Diagrams

To connect the motor:

1. Ensure that the motor chassis is properly earthed.
2. Connect the appropriate wire from the Motor Power cables to the M1, M2, M3, and PE terminals on the Platinum Whistle.
Make sure not to bundle the wires.
3. The phase connection is arbitrary as Elmo Application Studio (EAS II) will establish the proper commutation automatically during setup. When tuning a number of drives, you can copy the setup file to the other drives and thus avoid tuning each drive separately. In this case, the motor-phase order must be the same as on the first drive.
4. For high EMI environment, it is highly recommended to use a 4-wire shielded (not twisted) cable for the motor connection. The gauge is determined by the actual RMS current consumption of the motor.

Connect the cable shield to the closest ground connection at the motor end.

For better EMI performance, the shield should be connected to Earth Connection (heat sink mounting holes).

8.6 Main and Control Power

There are two power ratings for the Platinum Whistle:

- 100V is for the 10 to 95 VDC
- 200V is for the 20 to 195 VDC

For power rating 200V

Two DC power sources are required, a DC power source of 20 to 195V isolated from the Mains, and a control supply 12 to 60 VDC isolated from the Mains for the logic.

For power rating of 100V

Two DC power sources are required, a DC power source of 10 to 95V isolated from the Mains, and a control supply 12 to 60 VDC isolated from the Mains for the logic.



Note:

The Main power supply (10V to 95VDC or 20V to 195VDC) and Control supply (12 to 60VDC) must be isolated from the Mains.

Connect the DC power source cable to the VP+ and PR terminals on the main power connector.

To connect the main power:

1. The DC power supply source must be isolated from the Mains.
2. For best immunity, it is highly recommended to use shielded (not twisted) cables for the DC power source. A 3-wire shielded cable should be used. The gauge is determined by the actual current consumption of the motor.
3. Connect the cable shield to the closest earth connection near the power supply.
4. Connect the PE to the closest earth connection near the power supply.
5. Connect the PR to the closest earth connection near the power supply.
6. Before applying power, first, verify the polarity of the connection.

8.6.1 Control Supply

The Control Power (VL) for Safety configuration must be 12V to 60V. Refer to the Safety Power Configuration and to **Chapter 8 Input Power Supply in the MAN-P Safety Drive Manual**.

To connect your integration board to the control supply:

1. The source of the control supply must be isolated from the Mains.
2. For safety reasons, connect the return (common) of the control supply source to the closest earth connection near the control supply source.
3. Connect the cable shield to the closest earth connection near the control supply source.
4. Before applying power, verify the polarity of the connection.

8.6.2 Dual Power Supply for Safety Configuration

Two DC power sources are required for functional Safety. For details, specification, and connections, refer to Chapter 8 Input Power Supply in the Platinum Safety Drive.

- Main power isolated from the Mains
 - Main power 20 to 195V DC for 200V module
 - Main power 10 to 95V DC for 100V module
- Control Power supply must be 12V to 60V (isolated from the Mains)

The following figure describes the connection of main power and control.

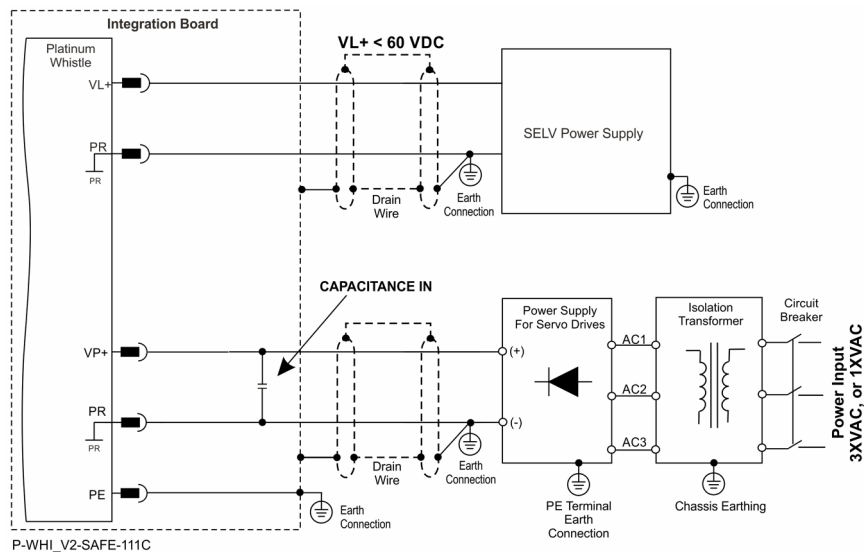

Figure 9: Power Supply Connection Diagram for Safety Configuration



Note:

Make sure to connect the PR to the closest earth connection near the power supply.

8.6.3 DC Bus Capacitance

CAPACITANCE IN for 100V: A DC Bus Capacitance must be connected between the VP+ and the PR in the integration board as shown in the following figure. It is recommended to use a combination of ceramic capacitor (up to 50uF) and electrolytic capacitor of 150uF.

An additional Capacitance of 900uF must be connected for the P-WHI modules 20/100 and 25/100.

CAPACITANCE IN for 200V: A DC Bus Capacitance must be connected between the VP+ and the PR in the integration board as shown in the following figure. It is recommended to use a combination of ceramic capacitor (up to 6uF) and electrolytic capacitor of 50uF.

8.7 Feedback

Refer to the section 16.6 Feedback, in the Platinum Safety Drive Manual for details, specification, and connections of the Feedback for safety.



Note:

For Safe IO, 11V for the Encoder is available. Make sure that the encoder supports 11V.

8.7.1 Feedback Port A

Port A supports the following sensor inputs as described in the table below:

- Incremental Encoder or absolute serial Encoder, depending on the specific model
- Differential pulse-width modulation (PWM) signal input can be connected to Port A
- Differential Pulse & Direction signal inputs can be connected to Port A

Pin (J2) Port A	Signal	Incremental Encoder	Absolute Serial Encoder
1	PortA_A+	Channel A +	Absolute encoder clock+
3	PortA_A-	Channel A -	Absolute encoder clock-
5	PortA_B+	Channel B+	Absolute encoder data+
7	PortA_B-	Channel B -	Absolute encoder data -
25, 31, 32, 48	COMRET	Common return	

8.7.1.1 Incremental Encoder

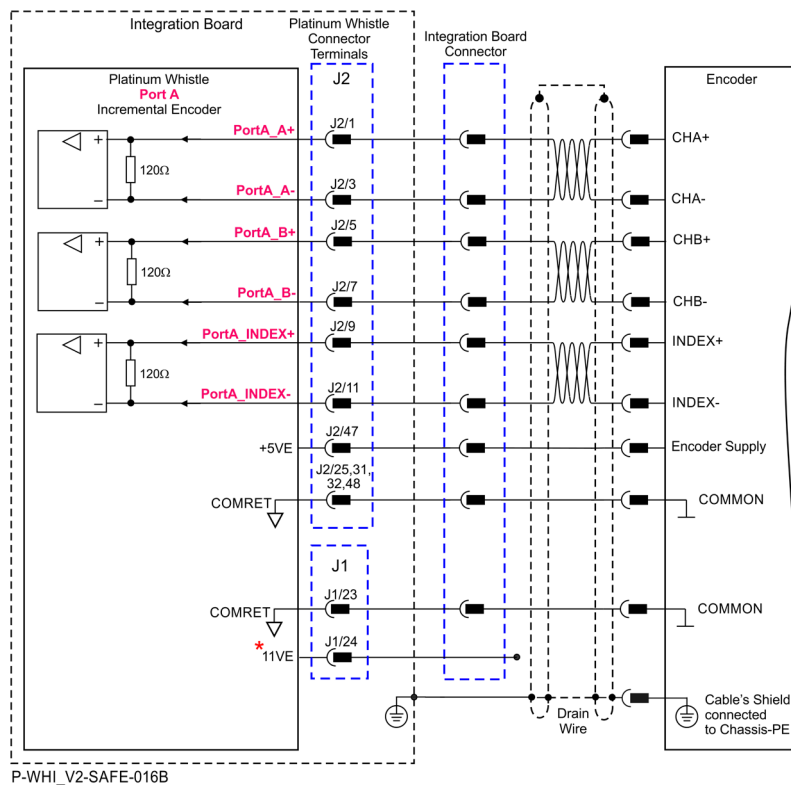

*** Note:**

If the Encoder supports 11V, then for Safety Capability F, 11V is available.

Figure 10: Port A Incremental Encoder Input – Recommended Connection Diagram

8.7.1.2 Absolute Serial Encoder

The following Absolute Encoder types are supported:

- Endat 2.2
- Biss C and Biss B
- SSI

The following is the diagram connection of the EnDat, Biss, SSI:

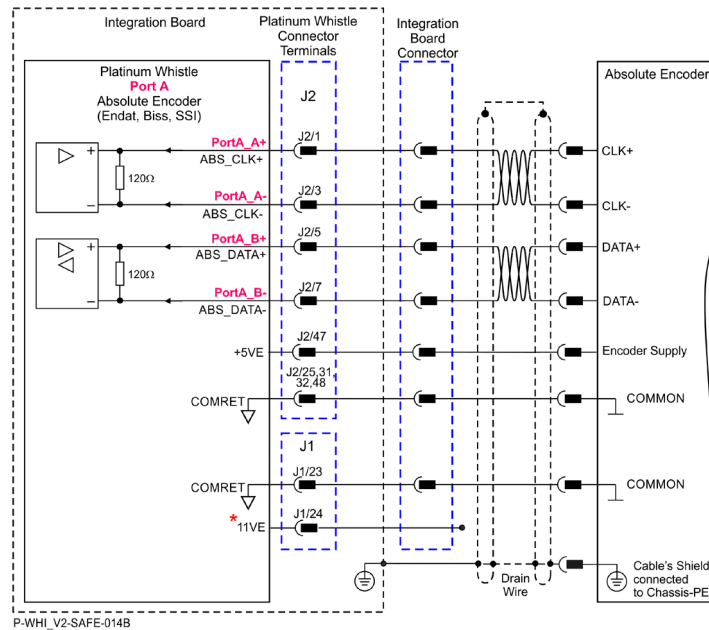

* **Note:** If the Encoder supports 11V, then for Safety Capability F, 11V is available.

Figure 11: Absolute Serial Encoder – Recommended Connection Diagram for Endat, Biss, SSI

8.7.1.3 Hiperface

The following figure describes the connection diagram.

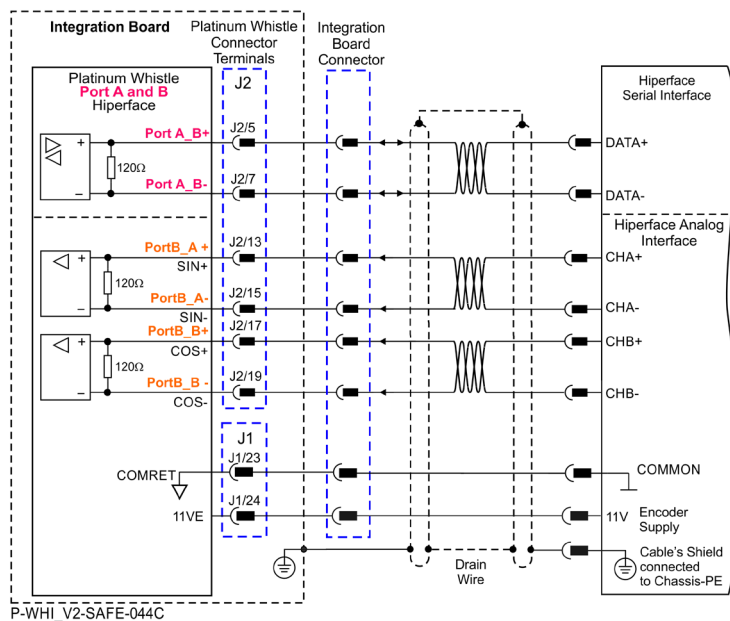

Figure 12: Absolute Serial Encoder – Recommended Connection Diagram for Stegmann Hiperface



Note: If there is no Safe IO, an external 11V supply is required.

8.7.2 Feedback Port B

Port B supports any of the following sensors described in the table below:

- Incremental Encoder interpolated analog Encoder or analog Hall sensors

Or

- Resolver (separate hardware option)

Differential PWM signal input can be connected to port B

Differential Pulse & Direction signal inputs can be connected to port B

Pin (J2) Port B	Signal	Incremental Encoder Function	Interpolated Analog Encoder Function	Resolver Function
		PWHI-MX-XXX/YYYYES		PWHI-MX-XXX/YYYYERX
13	PortB_A+	Channel A+	Sine+	Sine+
15	PortB_A-	Channel A -	Sine-	Sine-
17	PortB_B+	Channel B+	Cosine+	Cosine+
19	PortB_B-	Channel B-	Cosine-	Cosine-
21	PortB_INDEX+	Channel_Index+	Analog_Index+	RESOLVER_OUT+
23	PortB_INDEX-	Channel_Index-	Analog_Index-	RESOLVER_OUT-
25, 31, 32, 48	COMRET	Common return		

8.7.2.1 Incremental Encoder

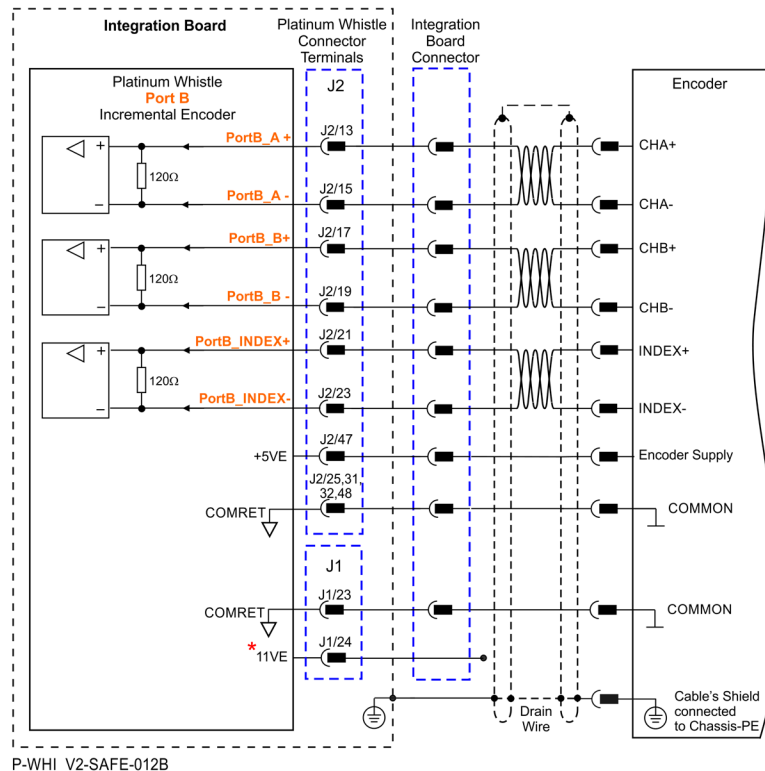

* **Note:** If the Encoder supports 11V, then for Safety Capability F, 11V is available.

Figure 13: Port B Incremental Encoder Input – Recommended Connection Diagram

8.7.2.2 Interpolated Analog (Sine/Cosine) Encoder

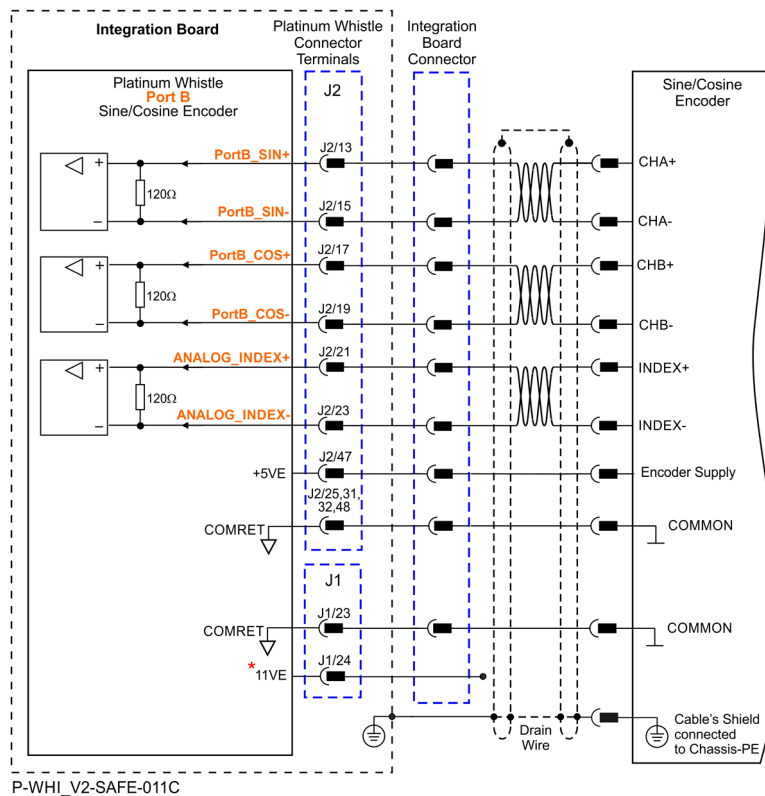

* Note: If the Encoder supports 11V, then for Safety Capability F, 11V is available.

Figure 14: Port B - Interpolated Analog Encoder Connection Diagram

8.7.2.3 Resolver

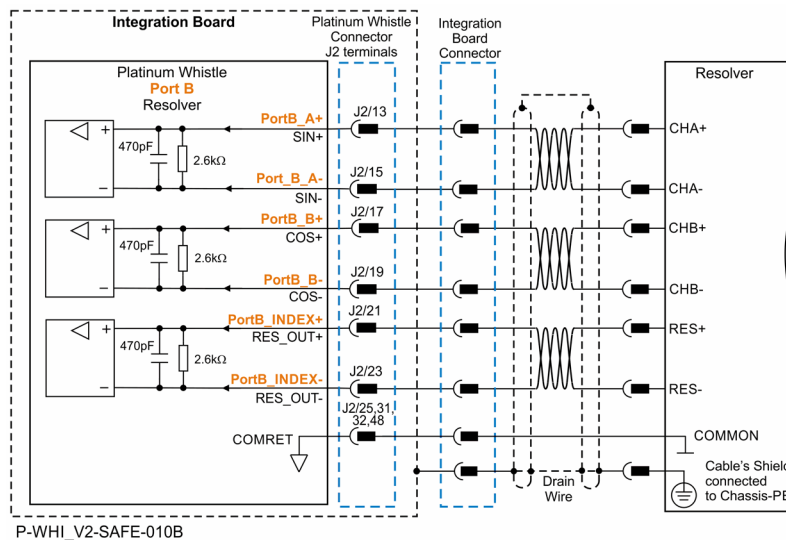

Figure 15: Port B – Resolver Connection Diagram

8.7.3 Feedback Port C

Port C provides the following sensor feedbacks as described in the table below:

- Incremental Encoder feedbacks
- Absolute Serial Encoder feedbacks
- Emulated Encoder output derived from port A, port B feedback inputs, or from internal variables

Pin (J2)		Incremental Encoder	Absolute Serial Encoder	General Outputs
Signal		Function	Function	Function
2	PortC_A-	Channel A -	Absolute encoder clock-	General Output A-
4	PortC_A+	Channel A +	Absolute encoder clock+	General Output A+
6	PortC_B-	Channel B -	Absolute encoder data -	General Output B-
8	PortC_B+	Channel B+	Absolute encoder data+	General Output B+
10	PortC_INDEX-	Index -	Reserved	General Output Index-
12	PortC_INDEX+	Index+	Reserved	General Output Index+

8.7.3.1 Incremental Encoder

The following Incremental Encoder types are supported:

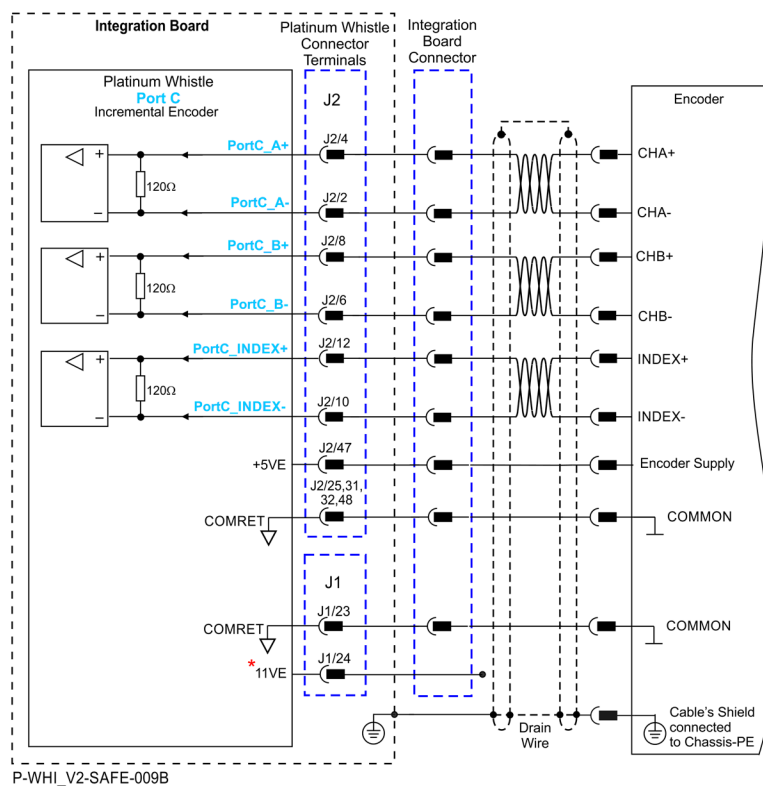

* **Note:** If the Encoder supports 11V, then for Safety Capability F, 11V is available.

Figure 16: Port C Incremental Encoder Input – Recommended Connection Diagram

8.7.3.2 Absolute Serial Encoder

Port C supports the following ABS feedback:

- Endat 2.2
- Biss C and Biss B
- SSI
- Panasonic, Tamagawa
- Nikon

The following is the diagram connection of the Endat, Biss, SSI:

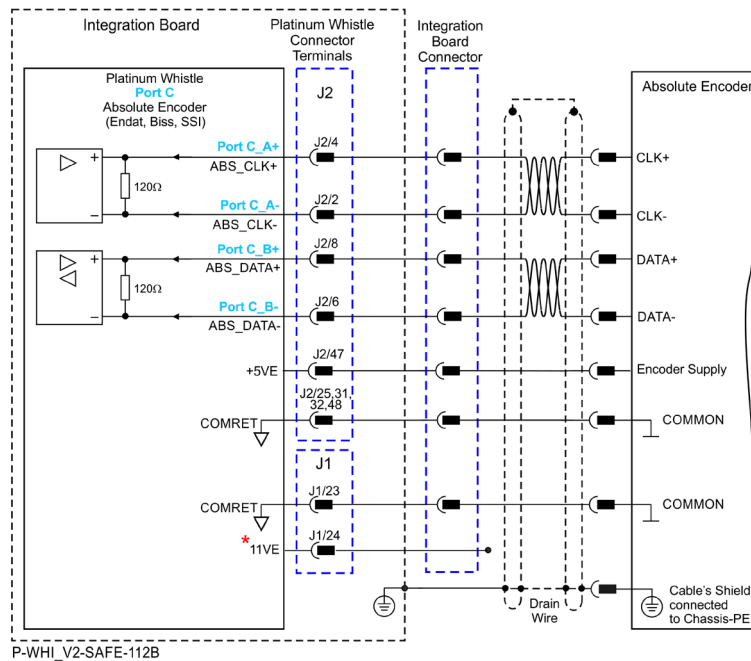

P-WHI_V2-SAFE-112B



*** Note:** If the Encoder supports 11V, then for Safety Capability F, 11V is available.

Figure 17: Absolute Serial Encoder – Recommended Connection Diagram for Endat, Biss, SSI

The following is the feedback diagram connection for Panasonic, Tamagawa, and Sanyo-Denki:

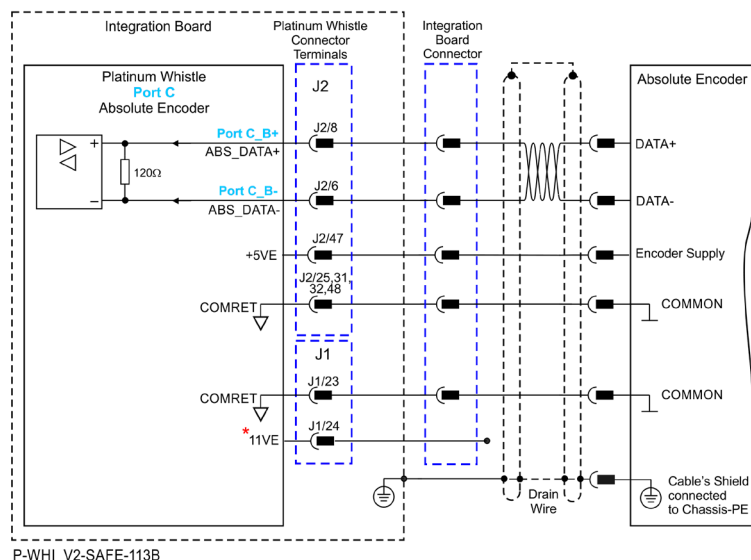

P-WHI_V2-SAFE-113B



*** Note:** If the Encoder supports 11V, then for Safety Capability F, 11V is available.

Figure 18: Absolute Serial Encoder – Recommended Connection Diagram for Panasonic, Tamagawa, Sanyo-Denki

8.7.3.3 Emulated Encoder Output

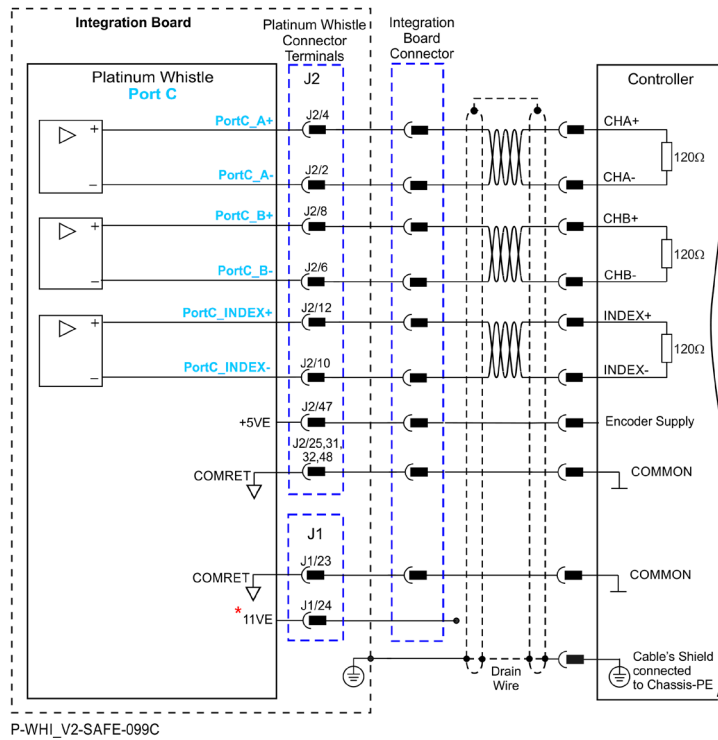
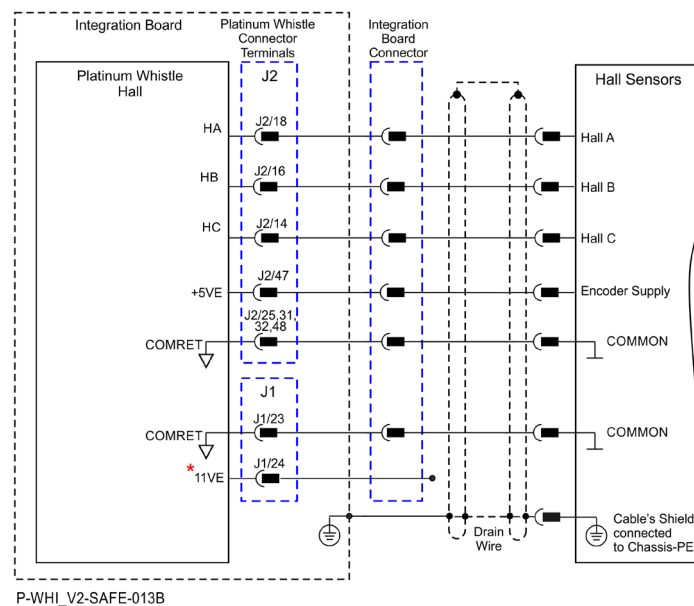

Figure 19: Emulated Encoder Differential Output – Recommended Connection Diagram

8.7.4 Feedback - Hall Sensors

Pin (J2)		Hall Encoder
Signal		Function
14	HC	Hall C Input
16	HB	Hall B Input
18	HA	Hall A Input



* Note: If the Encoder supports 11V, then for Safety Capability F, 11V is available.

Figure 20: Hall Sensors Connection Diagram

8.8 Analog Inputs

There is a single type of Analog Input in the Platinum Whistle:

- Analog Input 1 – Differential ± 10 V using Connector J2 in the Platinum Whistle

Refer to the Chapter 14 Analog Input section, in the Platinum Safety Drive Manual for specification details of the Analog Input.

8.8.1 Analog Input 1

The following circuit (Figure 21) describes the internal interface of the Analog input.

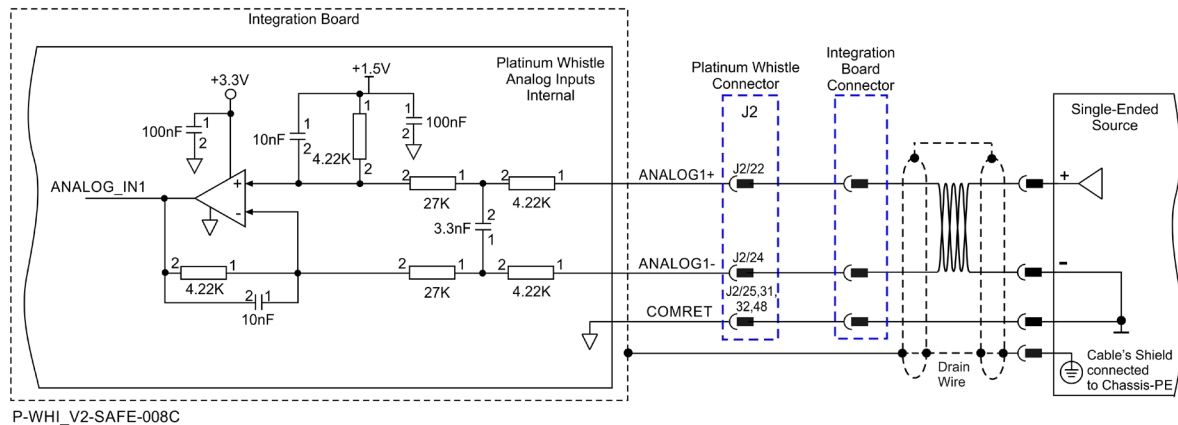

Figure 21: Analog Input with Differential ± 10 V

8.9 STO (Safe Torque Off)

Refer to the Chapter 10 Safe Torque Off (STO) section, in the Platinum Safety Drive Manual for details, specification and connection of the STO.

The diagram below describes the TTL connection for the STO input interfaces.

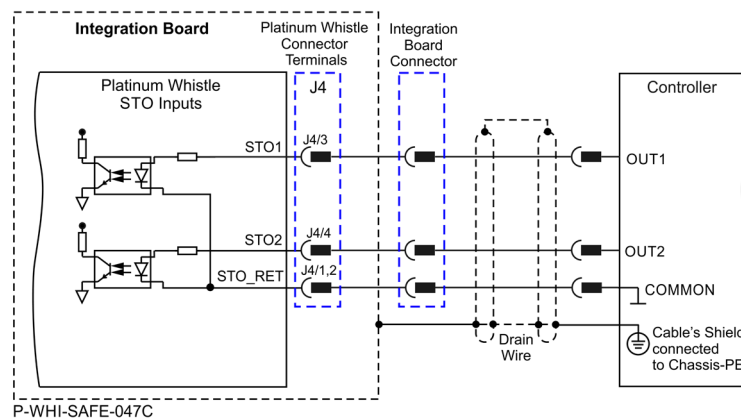

Figure 22: STO Input Connection – TTL

8.10 Safe Digital I/Os (Safety Capability: F)

Refer to the Chapter 12 Safe Digital IO section, in the Platinum Safety Drive Manual for details, specification and connection of IO for Safety.

8.10.1 Digital Input with Test Pulse

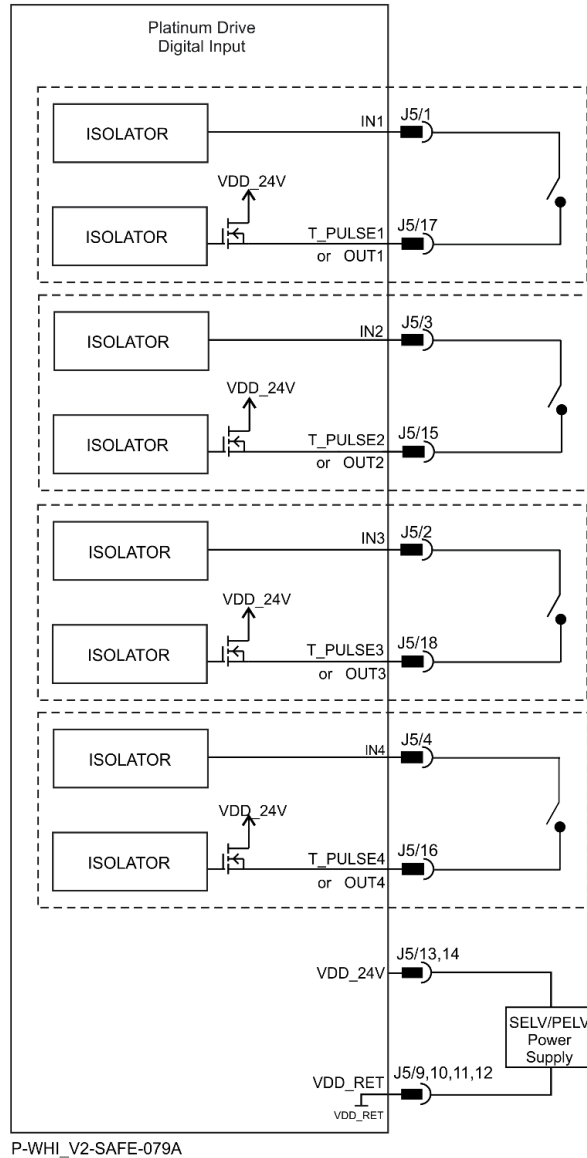

Figure 23: Digital input with Test Pulse

8.10.2 OSSD Digital Input

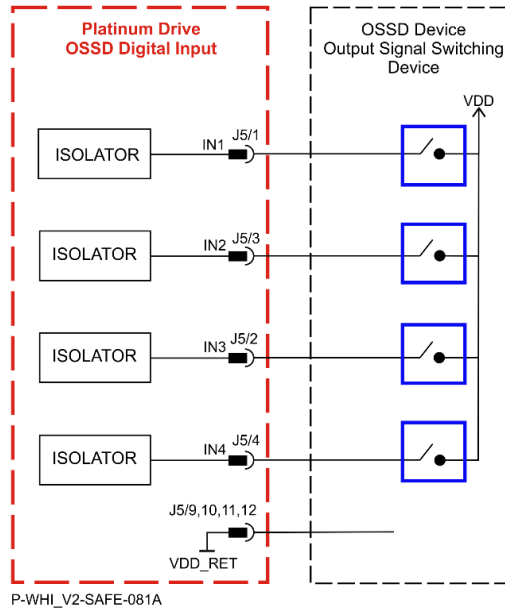

Figure 24: OSSD Digital input

8.10.3 Digital Output

The Platinum servo drive provides three configurations of the VDD connection as shown in the :

- K — VDD=24V, All Outputs
- L — VDD=24V, Outputs 1,2,3,4 and VDD=48V, Outputs 7,8
- N — VDD=48V, Outputs 7,8

8.10.3.1 Option L Configuration VDD_24 & VDD_48

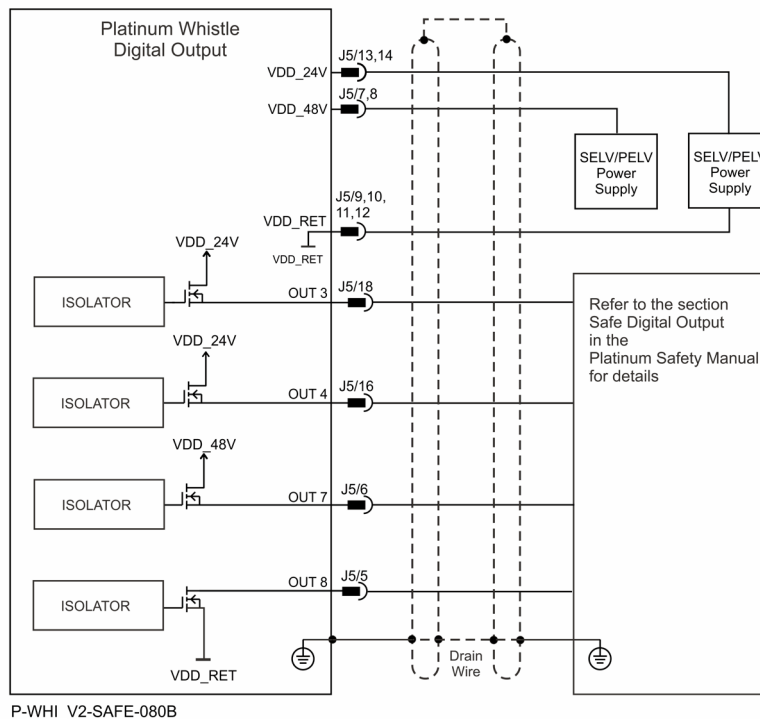

Figure 25: Safe Digital Outputs for Option L Configuration

8.10.3.2 Option K Configuration VDD_24

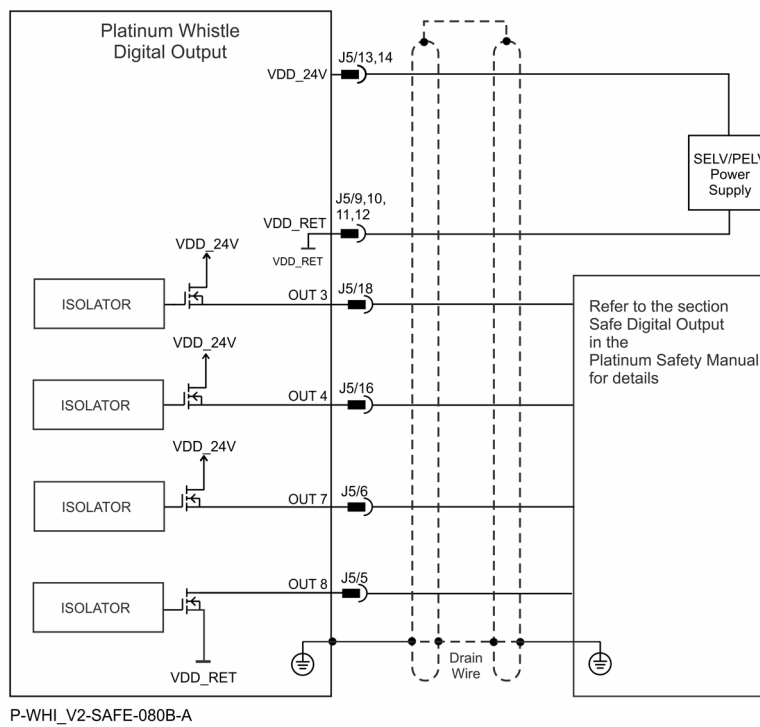

Figure 26: Safe Digital Outputs for K Option Configuration

8.10.3.3 Option N Configuration VDD_48

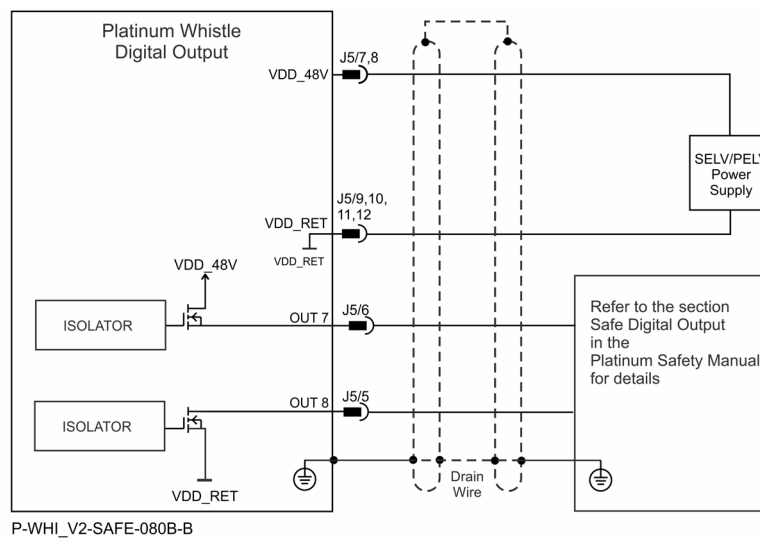

Figure 27: Safe Digital Outputs for Option N Configuration

8.11 Regular Digital IO

Refer to the section 16.7 Regular Digital IO, in the Platinum Safety Drive Manual for details, specification and connection of the Regular IO.

8.11.1 Digital Inputs

The following diagram describes the connection of IN1 to IN6 to opto coupler in order to isolate the digital inputs.

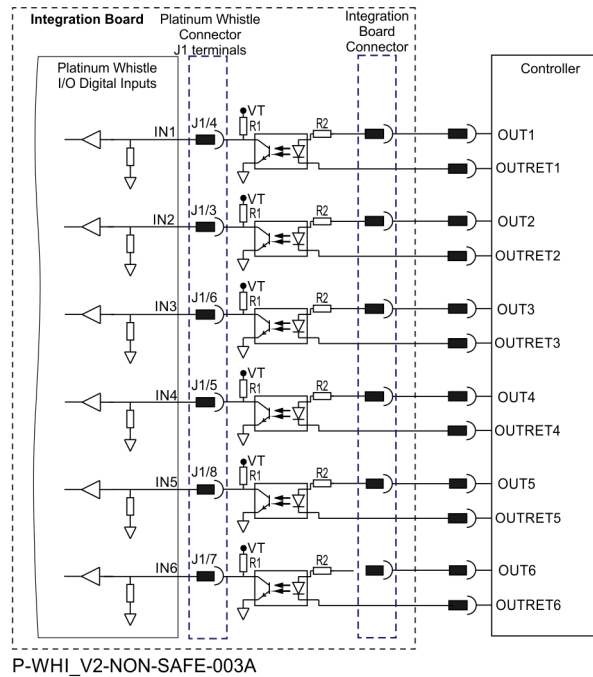

Figure 28: Digital Input TTL Mode Connection Diagram

8.11.2 Digital Outputs

The following diagram describes the connection of OUT1 to OUT4 to opto coupler in order to isolate the digital outputs.

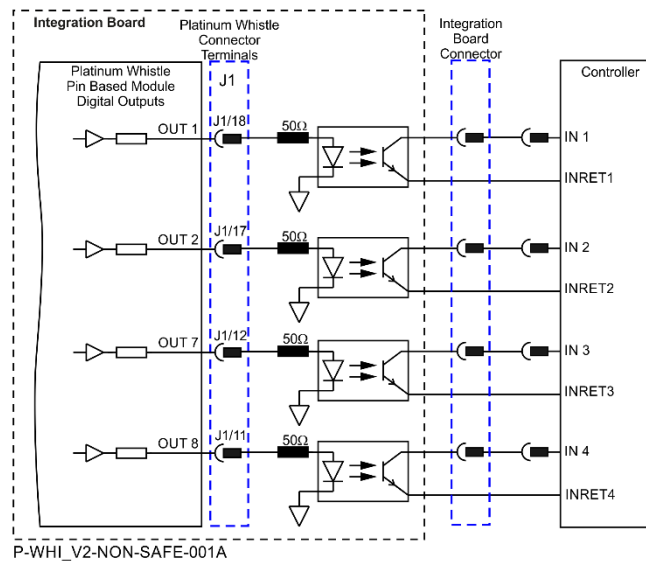

Figure 29: Digital Output TTL Mode Connection Diagram

8.12 Communication

8.12.1 RS232 TTL Logic Level

Figure 30 describes the standard RS232 connection diagram.

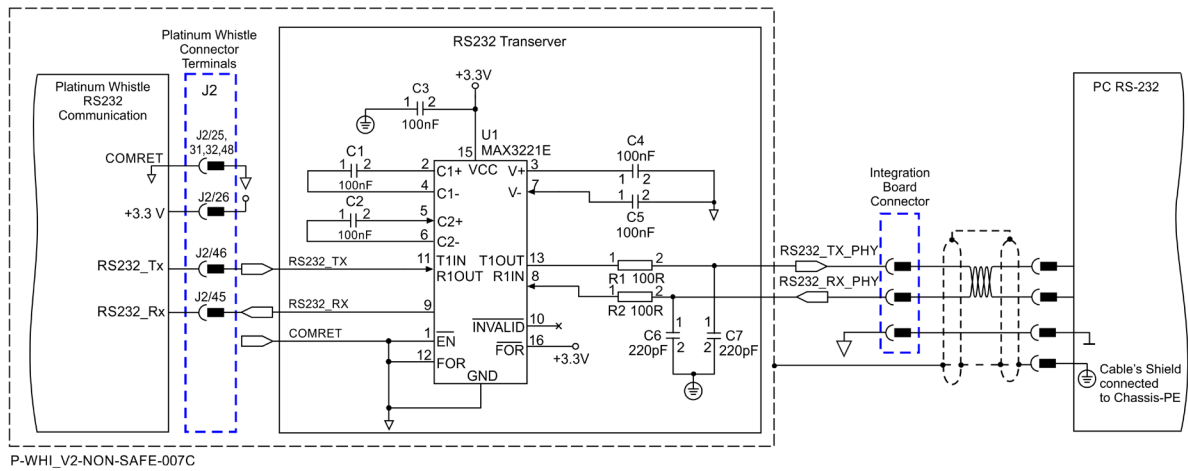

Figure 30: Standard RS232 Voltage Level incorporating RS232 TX/RX Transceiver Connection Diagram

8.12.2 USB 2.0

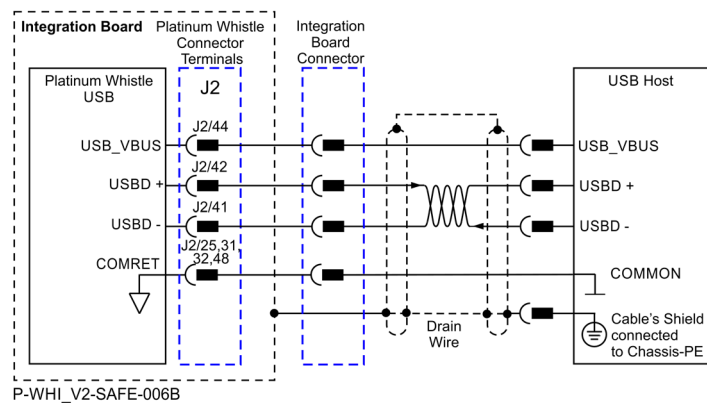

Figure 31: USB Network Diagram



Note:

In the Platinum Whistle the shield of the USB connector should be connected to the COMRET.

8.12.3 EtherCAT/Ethernet

The Platinum Whistle serves as an EtherCAT slave device, therefore it includes EtherCAT_IN and EtherCAT_OUT ports. It also includes LED indicators. The EtherCAT_OUT port can be configured to an Ethernet port.

The following figure describes the EtherCAT connection with a standard RJ-45 connector that includes transformer isolation.

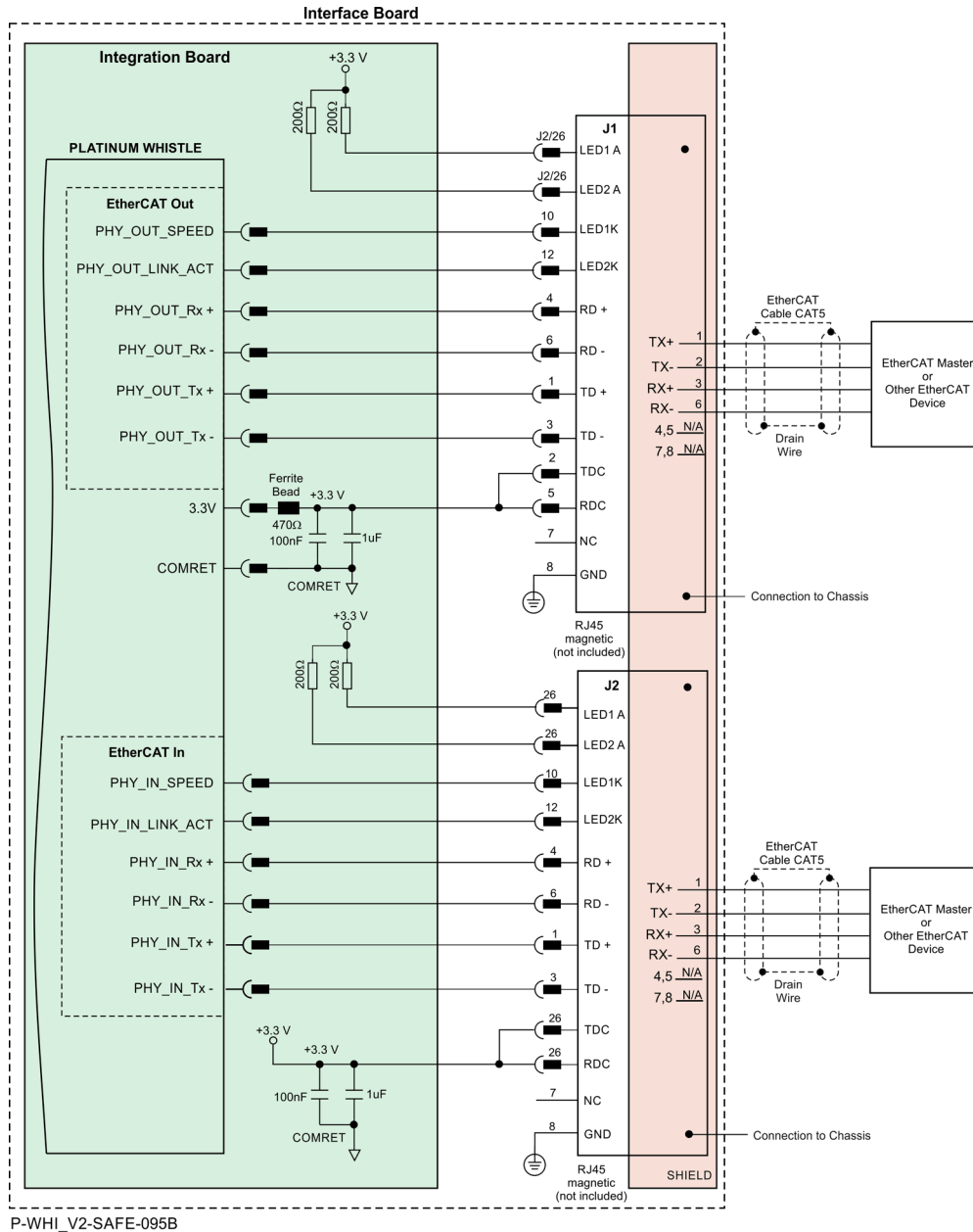

Figure 32: EtherCAT Connection Schematic with Diagram Sign of 3.3V

8.12.3.1 EtherCAT Status Indicator

For details of the EtherCAT Status Indicator, refer to section 16.10.2.4 EtherCAT Status Indicator in the [Platinum Safety Drive Manual](#) for full details.

8.13 CAN (Available within the near future)

Figure 33 displays the CAN connectivity.

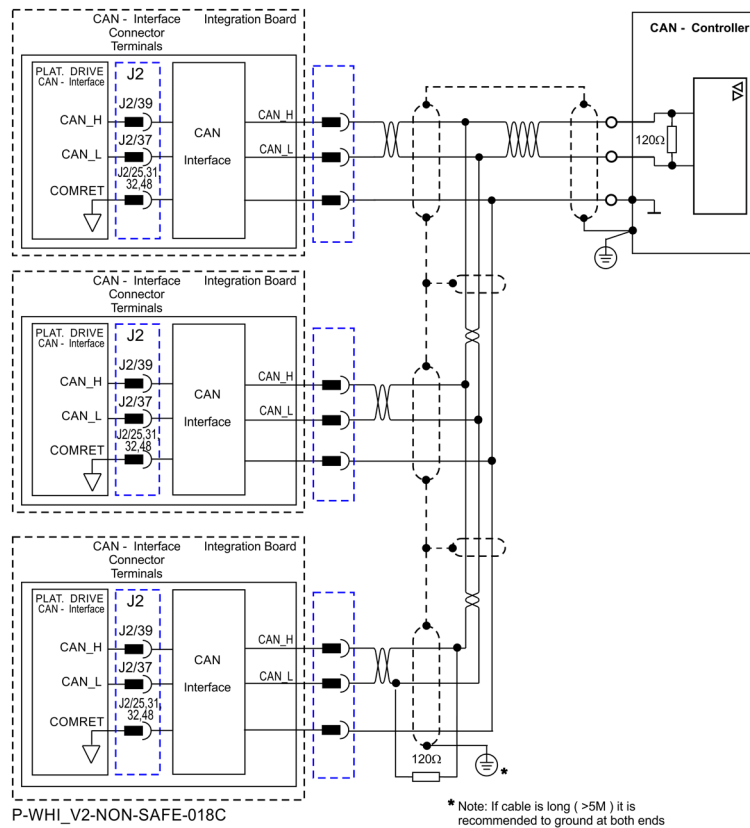

Figure 33: CANbus Connections



Important:

A 120 Ω termination resistor should be connected at each end of the network cable.

Chapter 9: Powering Up

After the Platinum Whistle is connected to its device, it is ready to be powered up.



Caution:

Before applying power, ensure that the DC supply is within the specified range and that the proper plus-minus connections are in order.

9.1 Initializing the System

After the Platinum Whistle has been connected and mounted, the system must be set up and initialized. This is accomplished using the *EASII*, Elmo's Windows-based software application. Install the application and then perform setup and initialization according to the directions in the *EASII User Manual*.

9.2 Heat Dissipation

The best way to dissipate heat from the Platinum Whistle is to mount it so that its heat-sink faces up. For best results leave approximately 10 mm of space between the Platinum Whistle's heat-sink and any other assembly.

9.2.1 Thermal Data

- Heat dissipation capability (θ): Approximately 10 °C/W
- Thermal time constant: Approximately 240 seconds (thermal time constant means that the Platinum Whistle will reach 2/3 of its final temperature after 4 minutes)
- Shut-off temperature: 86 °C to 88 °C (measured on the heat sink)

9.2.2 Heat Dissipation Data

Heat Dissipation is shown in graphically below:

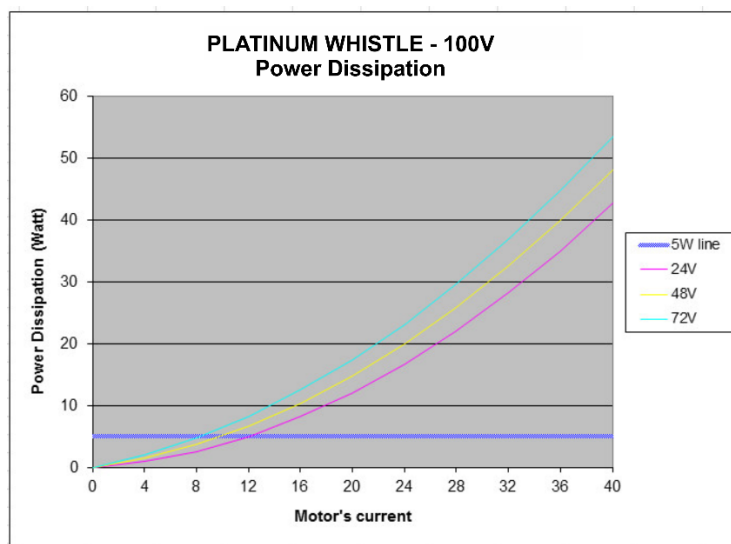

P-WHI-V2
SAFE-Graph 100V

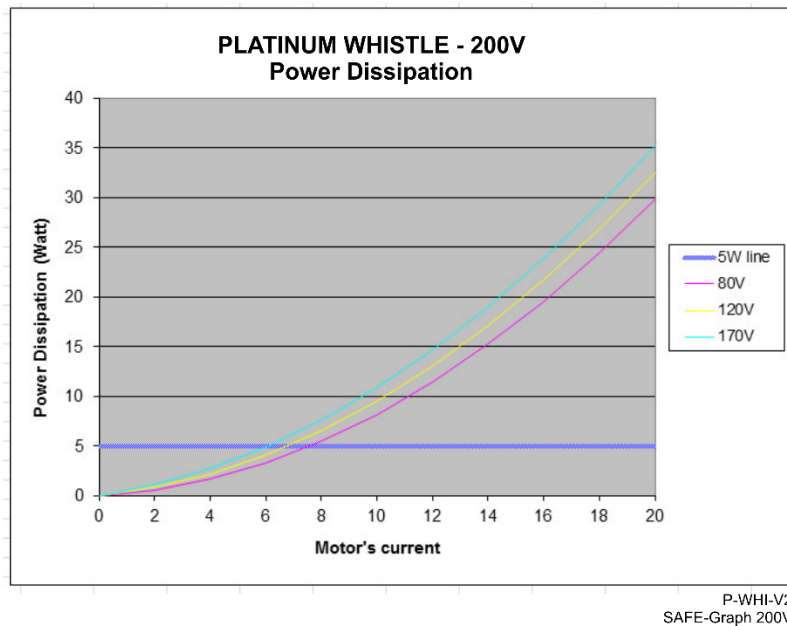

9.2.3 How to Use the Charts

The above charts indicate the net power conversion losses and exclude the control losses.

To determine if your application heat dissipation requires a heat sink:

1. Determine the power dissipation according to the "continuous current" and the DC bus voltage curve.
If the DC bus is not one of the two curves above, estimate the dissipation by interpolation. The estimation error is not critical.
2. The chart is calculated for continuous current operation, if the actual operation is pulsed current, add 25% to 30% to the power dissipation of the average (RMS) current.
3. When the Heat-Sink temperature reaches $\approx 85^{\circ}\text{C}$, the Platinum Whistle will shut down.
Design the system for continuous operation so that the maximum Heat Sink temperature should be no higher than between 80°C to 82°C .
4. For model **PWHI-Mz-zXXX/YYYzzM**
If the average heat dissipation is less than $\approx 4\text{W}$ to 5W (Average operating power of 300W to 600W) there will be no requirement for an additional external heat sink.
If the average Heat dissipation is higher than 4W then an additional heat dissipation means is required, usually by connecting to an additional external heat-sink.
5. When an external Heat-Sink is required, calculate the thermal resistance of the heat sink according to:

$$6. \quad \theta_{\text{C/W}} = \frac{80^{\circ}\text{C} - T_{\text{Ambient}}}{\text{Heat Dissipation}}$$

Chapter 10: Dimensions

This chapter provides detailed technical dimensions regarding the Platinum Whistle.

10.1 Safe IO Module (PWHI-MF-XXX/YYYzzM)

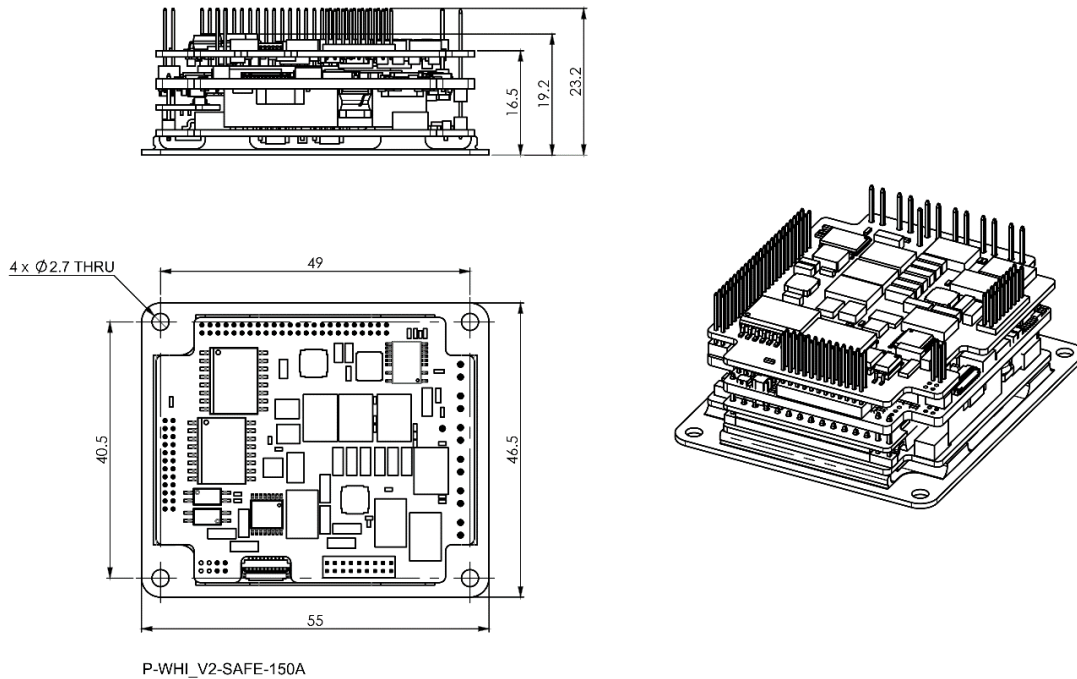

Figure 34: P-Whistle dimensions with Safe IO Module

10.2 Regular Safe Module (PWHI-MS-XXX/YYYzzM) or (PWHI-MT-XXX/YYYzzM)

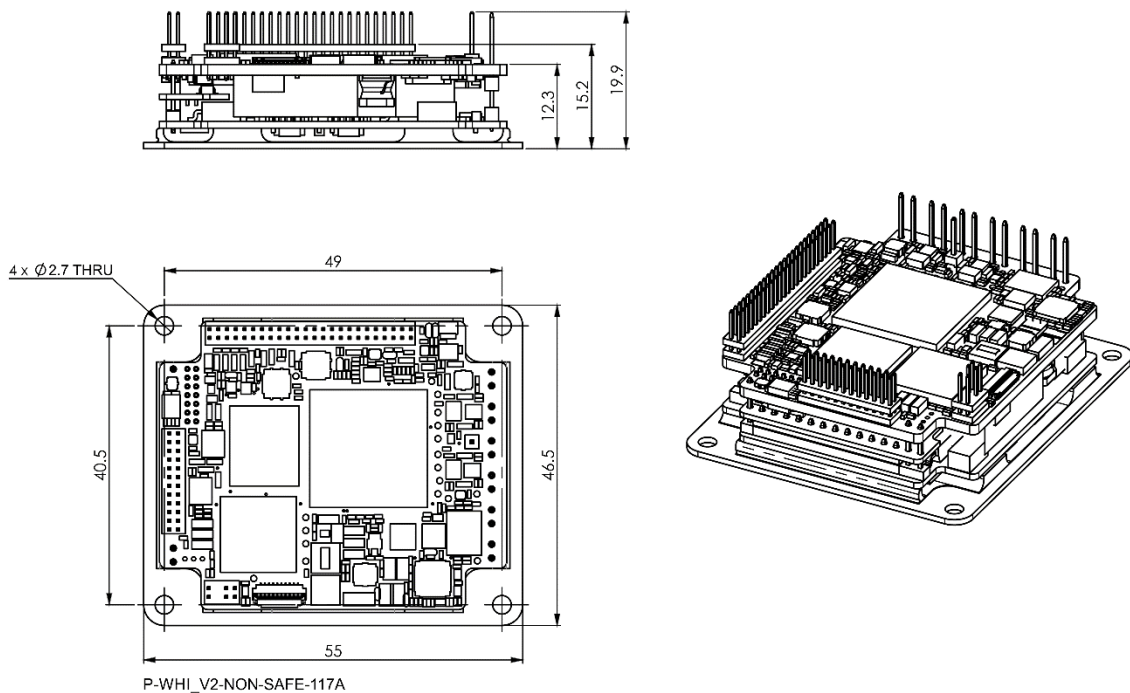

Figure 35: P-Whistle dimensions

Go Safer, Smarter, Smaller, Simpler.
Go Platinum.

Platinum 
by **Elmo**

www.elmcmc.com