

Description

JRS165R65, the silicon N-channel Enhanced MOSFETs, is obtained by advanced Super Junction technology which reduce the conduction loss, improve switching performance. The transistor is suitable device for SMPS, high speed switching and general purpose applications

FEATURES

- Fast Switching
- 100% avalanche tested
- Improved dv/dt capability
- RoHS product

Product Summary

Parameter	Value	Units
$V_{DS@Tj,max}$	700	V
I_D	24	A
$R_{DS(ON),Typ}@V_{GS}=10V$	0.135	Ω

APPLICATIONS

- High frequency switching mode power supply

100% DVDS Tested!
100% Avalanche Tested!

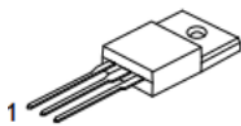

TO-220F

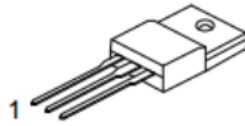

TO-220

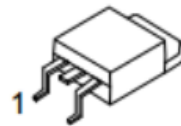

TO-263

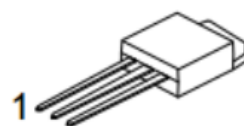

TO-262

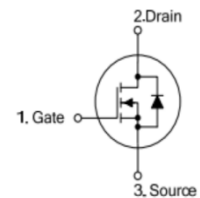

Schematic Diagram

Ordering Information

Device	Device Package	Product Code	Packing
JRS165R65-P	TO-220	S165R65	Tube
JRS165R65-A	TO-220F	S165R65	Tube
JRS165R65-I	TO-262	S165R65	Tube
JRS165R65-B	TO-263	S165R65	Tape Reel
JRS165R65-W	TO-3PN	S165R65	Tube

Absolute Maximum Ratings($T_C=25^{\circ}\text{C}$ unless otherwise noted)

Parameter	Symbol	Rating	Units
Drain-to-Source Voltage	V_{DSS}	650	V
Continuous Drain Current	I_D	24	A
Continuous Drain Current $T_C = 100^{\circ}\text{C}$		15	A
Pulsed Drain Current(Note1)	I_{DM}	72	A
Gate-to-Source Voltage	V_{GS}	± 30	V
Single Pulse Avalanche Energy(Note2)	E_{AS}	550	mJ
Peak Diode Recovery dv/dt (Note3)	dv/dt	15	V/ns
Power Dissipation TO-3PN\TO-262\TO-220\TO-263	PD	220	W
Derating Factor above 25°C		1.75	W/ $^{\circ}\text{C}$
Power Dissipation TO-220F	P_D	42	W
Derating Factor above 25°C		0.33	W/ $^{\circ}\text{C}$
Operating Junction and Storage Temperature Range	T_J, T_{stg}	150, -55 to 150	$^{\circ}\text{C}$
Maximum Temperature for Soldering	T_L	300	$^{\circ}\text{C}$

Thermal characteristics

Thermal characteristics TO-263\TO-262\TO-220\TO-3PN

Parameter	Symbol	Rating	Units
Junction-to-Case	$R_{\theta JC}$	0.57	$^{\circ}\text{C}/\text{W}$
Junction-to-Ambient	$R_{\theta JA}$	62.5	$^{\circ}\text{C}/\text{W}$

Thermal characteristics TO-220F

Parameter	Symbol	Rating	Units
Junction-to-Case	$R_{\theta JC}$	3	$^{\circ}\text{C}/\text{W}$
Junction-to-Ambient	$R_{\theta JA}$	80	$^{\circ}\text{C}/\text{W}$

Electrical Characteristics (TC=25°C unless otherwise noted)

Parameter	Symbol	Test Conditions	Values			Units
			Min	Typ	Max	
OFF Characteristics						
Drain to Source Breakdown Voltage	V_{DSS}	$V_{GS}=0V, I_D=250\mu A$	650	-	-	V
Bvdss Temperature Coefficient	$\frac{\Delta B_{VDSS}}{\Delta T_J}$	$I_D=250\mu A$, Reference 25°C	-	0.67	-	V/°C
Drain to Source Leakage Current	I_{DSS}	$V_{DS} = 650V$, $V_{GS} = 0V$, $T_j = 25^\circ C$	-	-	1	μA
		$V_{DS} = 520V$, $V_{GS} = 0V$, $T_j = 125^\circ C$	-	-	100	μA
Gate to Source Forward Leakage	$I_{GSS(F)}$	$V_{GS} = +30V$	-	-	100	nA
Gate to Source Reverse Leakage	$I_{GSS(R)}$	$V_{GS} = -30V$	-	-	-100	nA
ON Characteristics						
Drain-to-Source OnResistance	$R_{DS(ON)}$	$V_{GS}=10V$, $I_D=9A$ (Note4)	-	0.135	0.16	Ω
Gate Threshold Voltage	$V_{GS(TH)}$	$V_{DS}=V_{GS}$, $I_D= 250\mu A$ (Note4)	2.5	-	4.5	V
Dynamic Characteristics						
Gate resistance	R_g	$f = 1.0MHz$	-	3.2	-	Ω
Output Capacitance	C_{iss}	$V_{GS} = 0V$ $V_{DS} = 25V$ $f = 1.0MHz$	-	1830	-	PF
Input Capacitance	C_{oss}		-	1050	-	
Reverse Transfer Capacitance	C_{rss}		-	52	-	

Switching Characteristics, at $T_J = 25\text{ }^\circ\text{C}$

Parameter	Symbol	Test Conditions	Values			Units
			Min.	Typ.	Max.	
Turn-on Delay Time	$t_{d(on)}$	$I_D = 11\text{A}$ $V_{DD} = 400\text{V}$ $V_{GS} = 10\text{V}$ $R_G = 2\Omega$	-	13	-	ns
Rise Time	t_r		-	8	-	
Turn-Off Delay Time	$t_{d(off)}$		-	38	-	
Fall Time	t_f		-	7	-	
Total Gate Charge	Qg	$I_D = 11\text{A}$ $V_{DD} = 400\text{V}$ $V_{GS} = 10\text{V}$	-	43	-	nC
Gate to Source Charge	Qgs		-	10	-	
Gate to Drain ("Miller") Charge	Qgd		-	16	-	

Source-Drain Diode Characteristics

Parameter	Symbol	Test Conditions	Values			Units
			Min.	Typ.	Max.	
Continuous Source Current (Body Diode)	I_S	TC=25 °C	-	-	24	A
Maximum Pulsed Current (Body Diode)	I_{SM}		-	-	72	A
Diode Forward Voltage	V_{SD}	$I_S = 11\text{A}$, $V_{GS} = 0\text{V}$ (Note4)	-	-	1.2	V
Reverse Recovery Time	T_{rr}	$I_S = 11\text{A}$, $T_J = 25\text{ }^\circ\text{C}$ $dI_F/dt = 100\text{A}/\mu\text{s}$, $V_{GS} = 0\text{V}$	-	380	-	ns
Reverse Recovery Charge	Q_{rr}		-	5320	-	nC
Reverse Recovery Current	I_{rrm}		-	28	-	A

Note1: Pulse width limited by maximum junction temperature

Note2: $L = 20\text{mH}$, $V_{DS} = 50\text{V}$, Start $T_J = 25\text{ }^\circ\text{C}$

Note3: $I_{SD} = 11\text{A}$, $dI/dt \leq 100\text{A}/\mu\text{s}$, $V_{DD} \leq B_{VDS}$, Start $T_J = 25\text{ }^\circ\text{C}$

Note4: Pulse width $t_p \leq 300\mu\text{s}$, $\delta \leq 2\%$

Characteristics Curves

Figure 1a Safe Operating Area (No FullPAK)

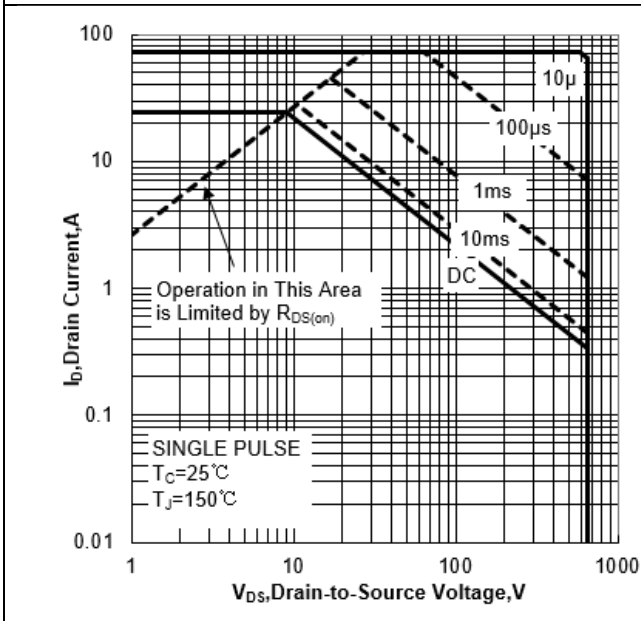

Figure 1b Safe Operating Area (FullPAK)

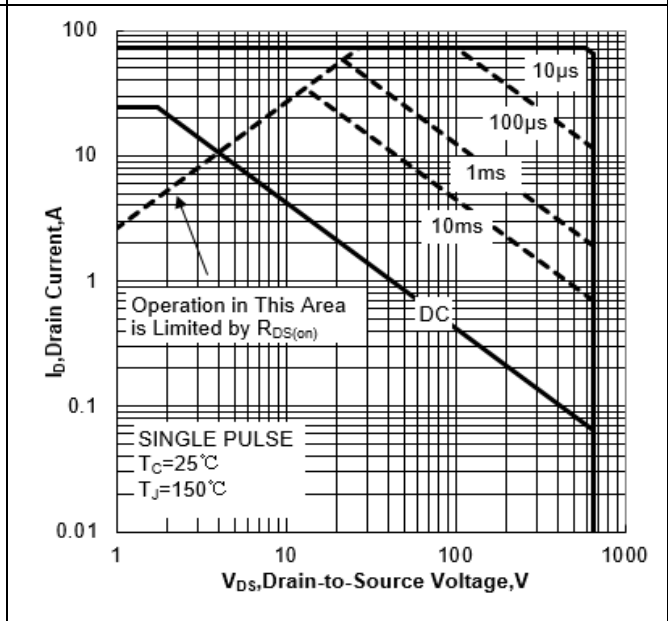

Figure 2a Power Dissipation (No FullPAK)

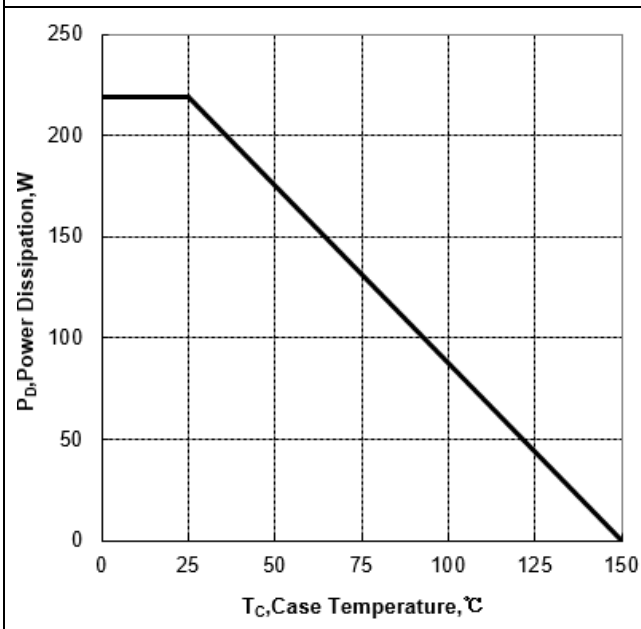

Figure 2b Power Dissipation (FullPAK)

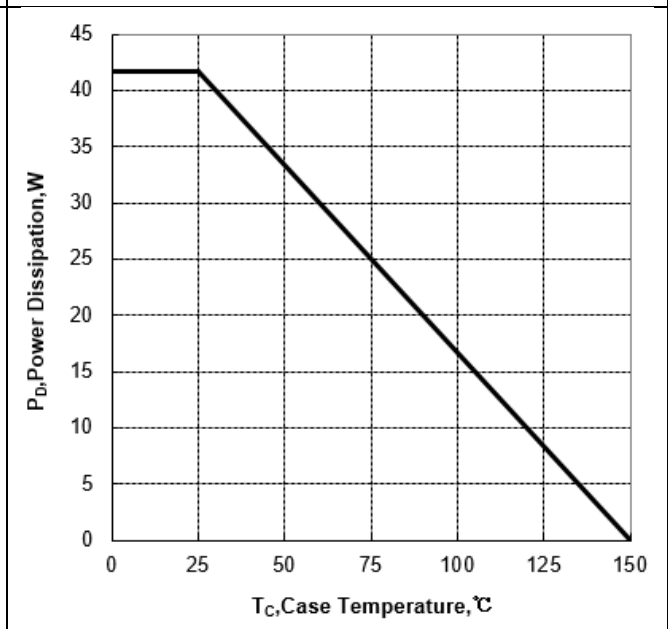

Figure 3a Max Thermal Impedance (No FullPAK)

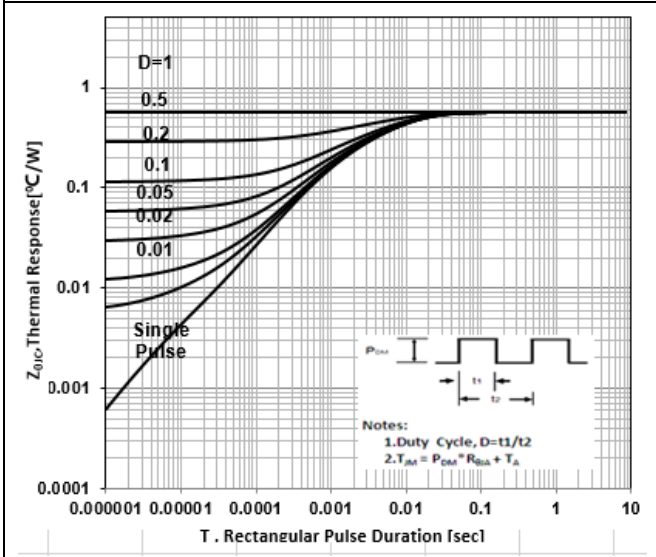

Figure 3b Max Thermal Impedance (FullPAK)

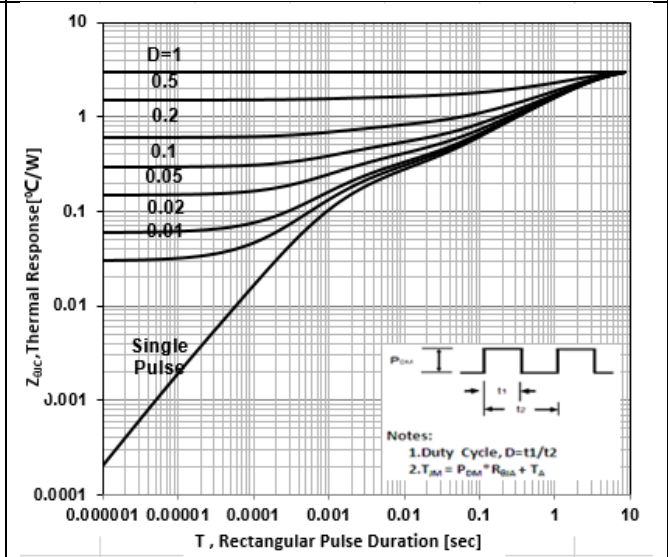

Figure 4 Typical Output Characteristics

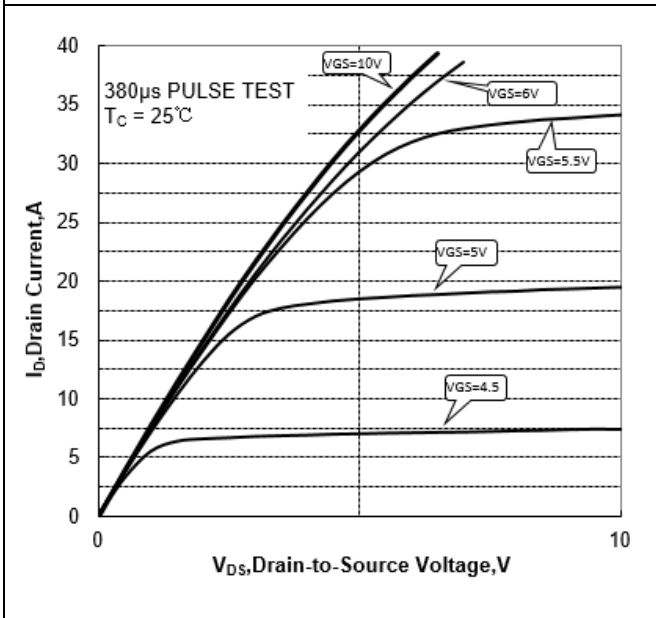

Figure 5 Typical Transfer Characteristics

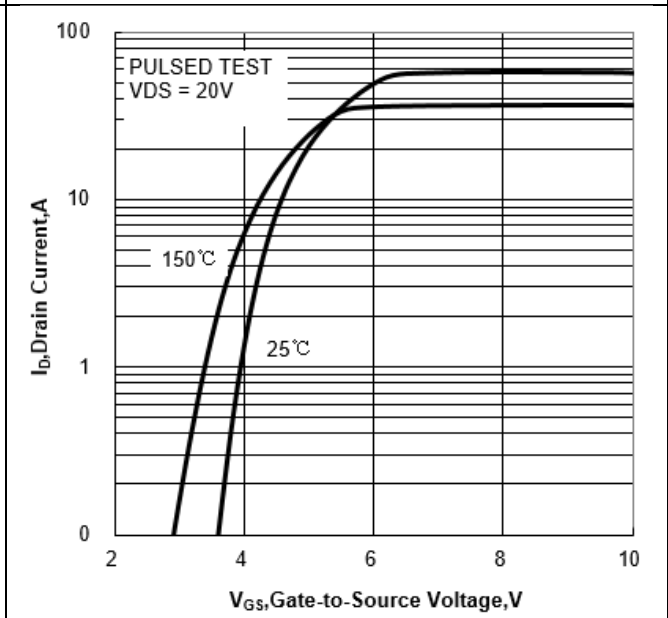

Figure 6 Typical Drain to Source ON Resistance vs Drain Current

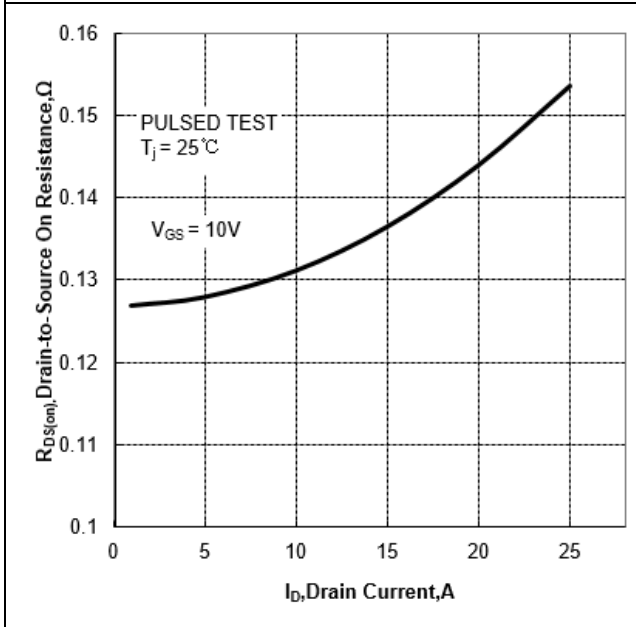

Figure 7 Typical Drain to Source on Resistance vs Junction Temperature

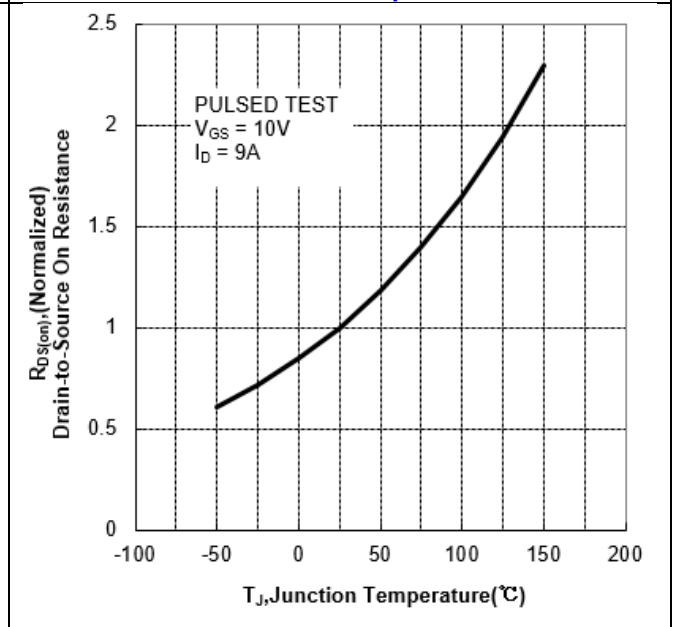

Figure 8 Typical Theshold Voltage vs Junction Temperature

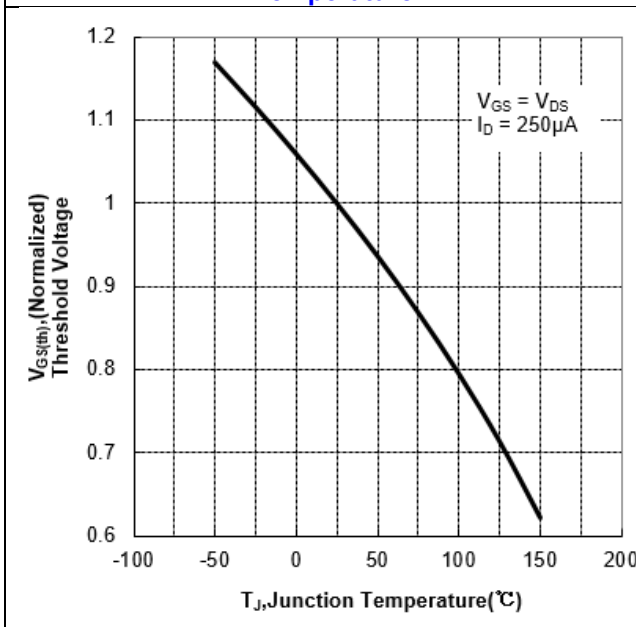

Figure 9 Typical Breakdown Voltage vs Junction Temperature

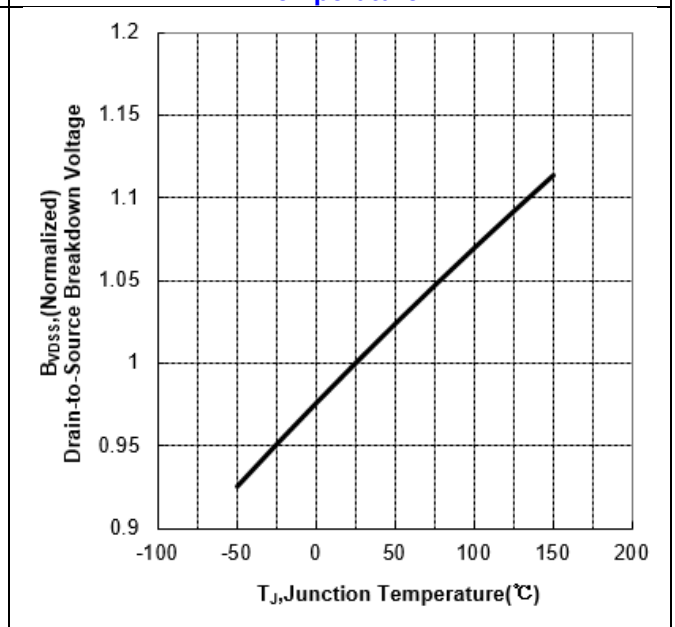

Figure 10 Typical Theshold Voltage vs Junction Temperature

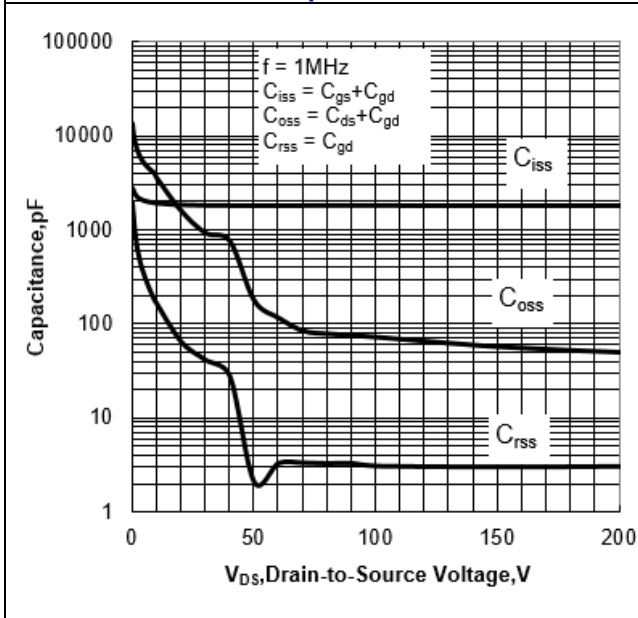
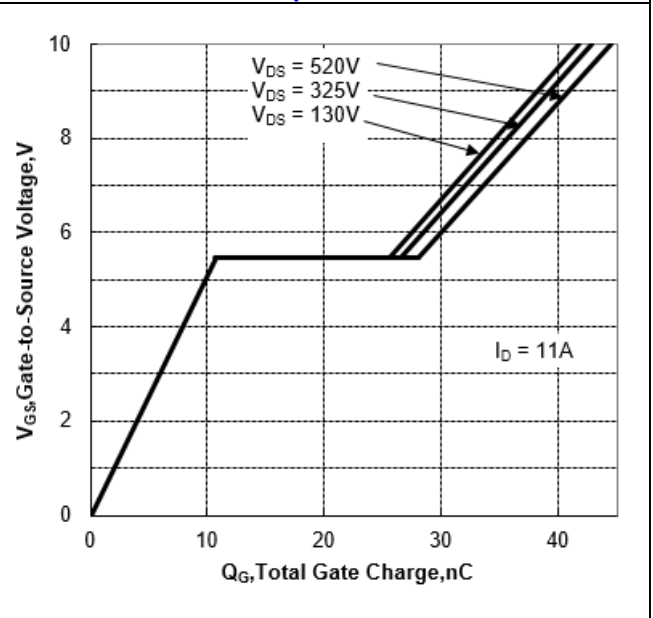

Figure 11 Typical Breakdown Voltage vs Junction Temperature



Test Circuit and Waveform

Figure 12 Gate Charge Test Circuit

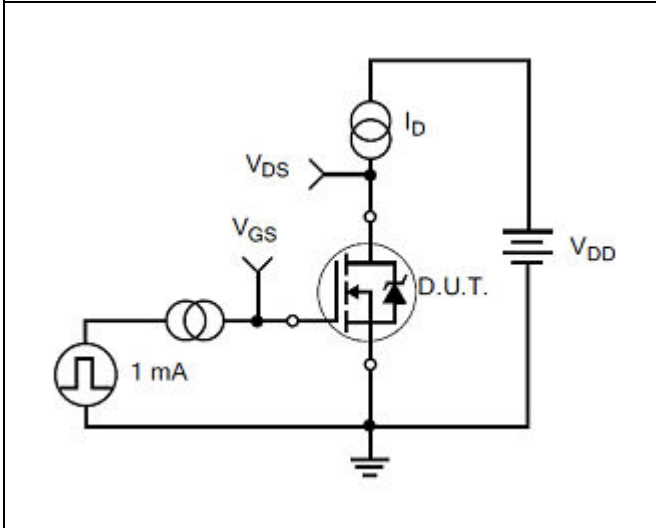

Figure 13 Gate Charge Waveforms

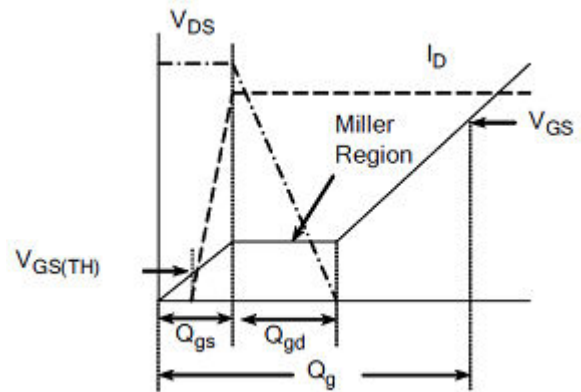

Figure 14 Resistive Switching Test Circuit

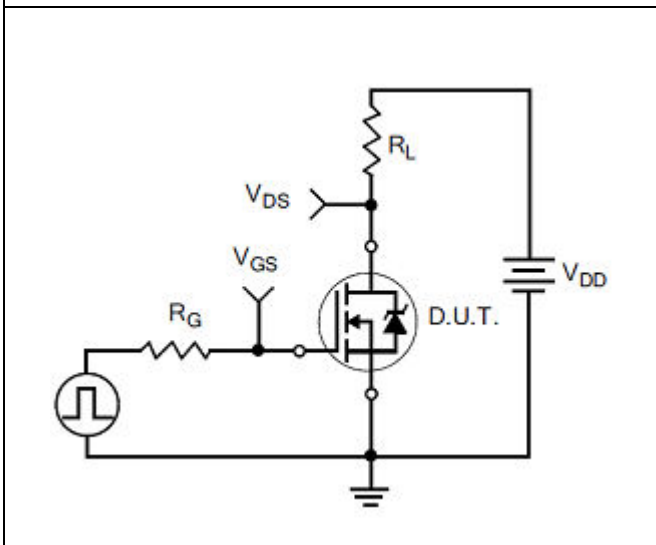

Figure 15 Resistive Switching Waveforms

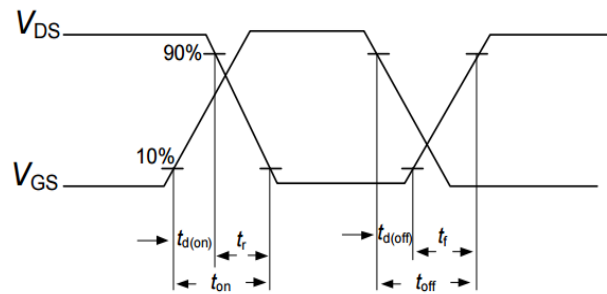

Figure 16 Diode Reverse Recovery Test Circuit

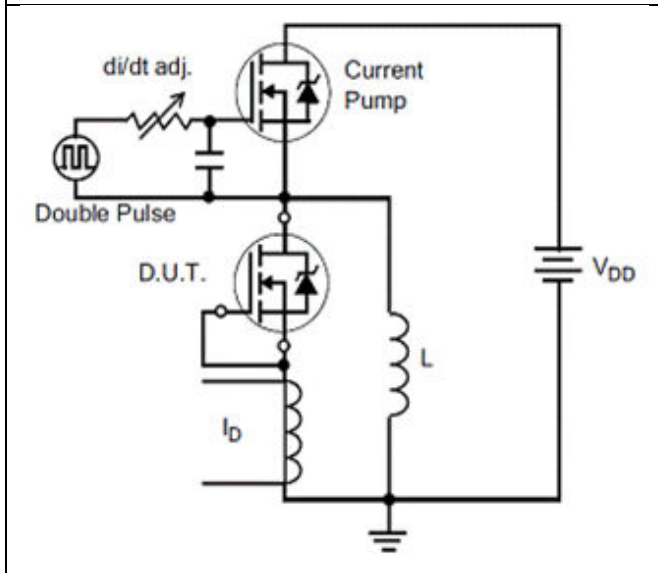

Figure 17 Diode Reverse Recovery Waveform

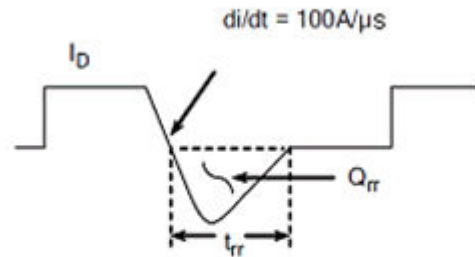

Figure 18 Unclamped Inductive Switching Test Circuit

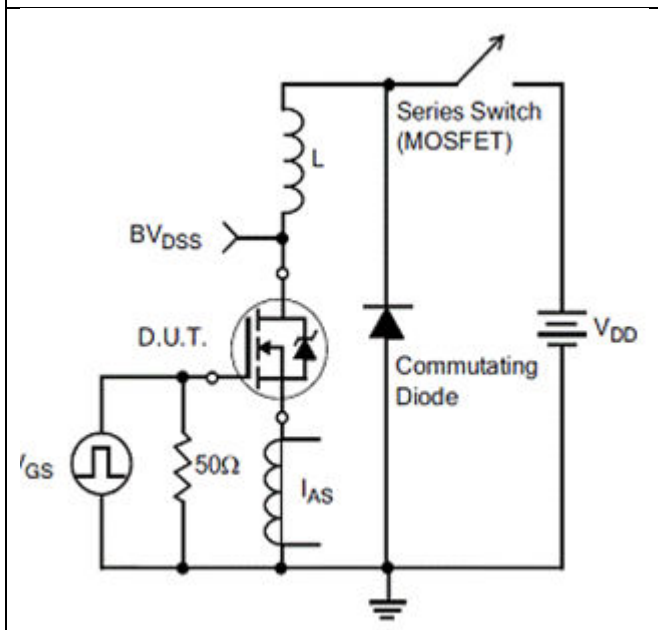
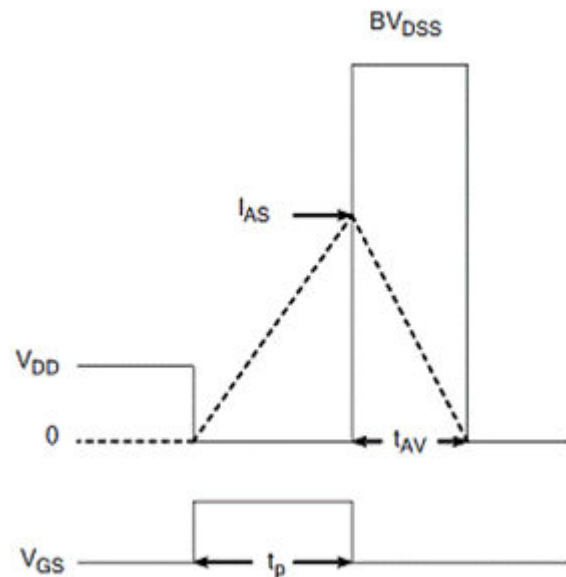
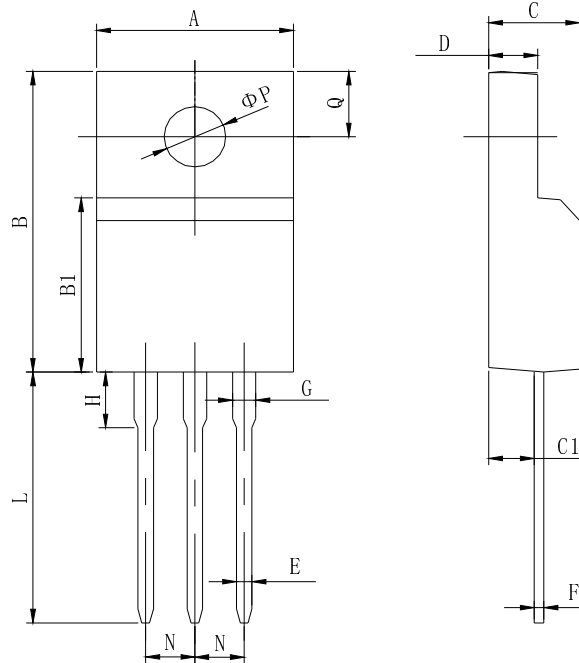

Figure 19 Unclamped Inductive Switching Waveform



Package Description



Items	Values(mm)	
	MIN	MAX
A	9.60	10.4
B	15.4	16.2
B1	8.90	9.50
C	4.30	4.90
C1	2.10	3.00
D	2.40	3.00
E	0.60	1.00
F	0.30	0.60
G	1.12	1.42
H	3.40	3.80
	1.60	2.90
L	12.0	14.0
N	2.34	2.74
Q	3.15	3.55
ϕP	2.90	3.30

TO-220F Package

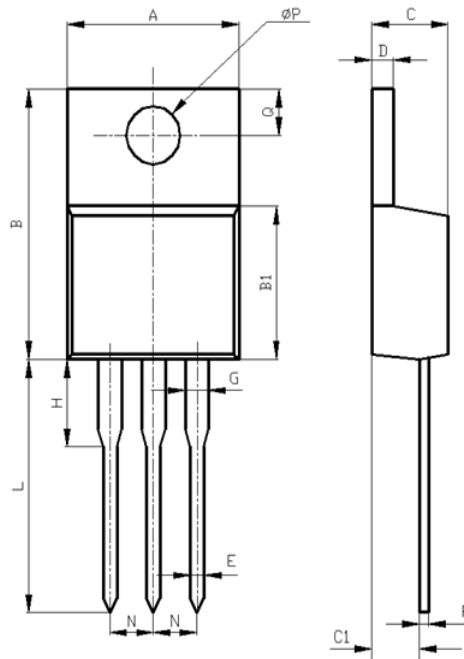

Items	Values(mm)	
	MIN	MAX
A	9.60	10.6
B	15.0	16.0
B1	8.90	9.50
C	4.30	4.80
C1	2.30	3.10
D	1.20	1.40
E	0.70	0.90
F	0.30	0.60
G	1.17	1.37
H	2.70	3.80
L	12.6	14.8
N	2.34	2.74
Q	2.40	3.00
Ø P	3.50	3.90

TO-220 Package

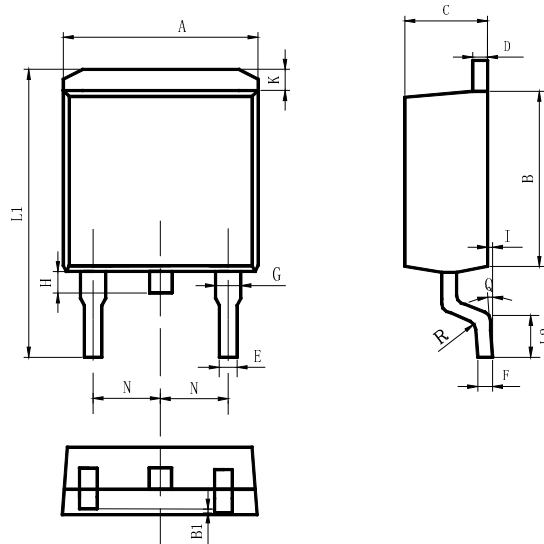

Items	Values(mm)	
	MIN	MAX
A	9.80	10.40
B	8.90	9.50
B1	0	0.10
C	4.40	4.80
D	1.16	1.37
E	0.70	0.95
F	0.30	0.60
G	1.07	1.47
H	1.30	1.80
K	0.95	1.37
L1	14.50	16.50
L2	1.60	2.30
I	0	0.2
Q	0°	8°
R	0.4	
N	2.39	2.69

TO-263 Package

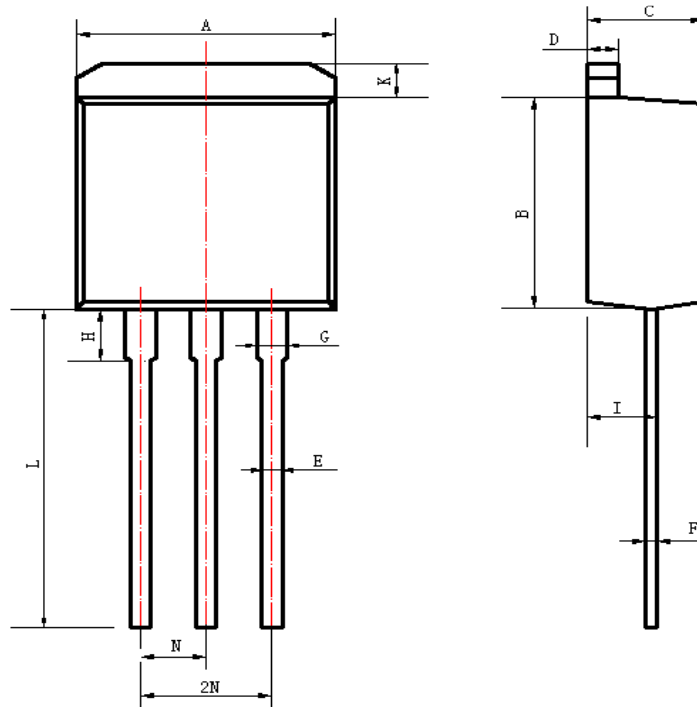

Items	Values(mm)	
	MIN	MAX
A	9.80	10.40
B	8.90	9.50
C	4.30	4.80
D	1.15	1.40
E	0.70	0.91
F	0.28	0.55
G	1.07	1.47
H	3.37	3.77
I	2.50	2.90
K	0.90	1.40
L	12.7	14.7
N	2.35	2.70

TO-262 Package