

Description

JRS360R60, the silicon N-channel Enhanced MOSFETs, is obtained by advanced Super Junction technology which reduce the conduction loss, improve switching performance. The transistor is suitable device for SMPS, high speed switching and general purpose applications.

FEATURES

- Fast Switching
- 100% avalanche tested
- Improved dv/dt capability
- RoHS product

Product Summary

Parameter	Value	Unit
V_{DSS}	650	V
I_D	11	A
$R_{DS(on)}$.typ @ $V_{GS}=10V$	0.31	Ω

APPLICATIONS

- High frequency switching mode power supply

100% DVDS Tested!
100% Avalanche Tested!



TO-220



TO-220F

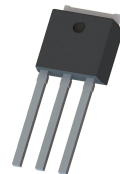

TO-251



TO-263



TO-252

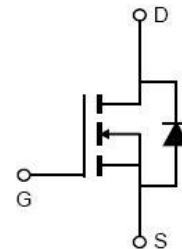

Schematic Diagram

Ordering Information

Device	Device Package	Product Code	Packing
JRS360R60-P	TO-220	S360R60	Tube
JRS360R60-A	TO-220F	S360R60	Tube
JRS360R60-U	TO-251	S360R60	Tube
JRS360R60-D	TO-252	S360R60	Tape Reel
JRS360R60-B	TO-263	S360R60	Tape Reel

Absolute Maximum Ratings(TC=25°C unless otherwise noted)

Parameter	Symbol	Rating	Units
Drain-Source Voltage	V_{DSS}	600	V
Continuous Drain Current	I_D	11	A
Continuous Drain Current TC =100°C	I_D	6.93	A
Pulsed Drain Current	I_{DM} ^{Note1}	33	A
Gate-Source Voltage	V_{GS}	±30	V
Avalanche Energy	E_{AS} ^{Note2}	260	mJ
Peak Diode Recovery dv/dt	dv/dt ^{Note3}	15	V/ns
Power Dissipation (TO-220 TO-263 TO-251 TO-252)	P_D	110	W
Derating Factor above 25°C (TO-220F)		0.8	W/°C
Power Dissipation	P_D	31	W
Derating Factor above 25°C		0.25	W/°C
Operating Junction and Storage Temperature Range	T_J, T_{STG}	150, - 55 to 150	°C
Maximum Temperature for Soldering	T_L	300	°C

Thermal characteristics(TO-220 TO-263 TO-251 TO-252)

Parameter	Symbol	Max	Units
thermal resistance , Junction- Case	$R_{\theta JC}$	1.25	°C/W
thermal resistance , Junction-Ambient	$R_{\theta JA}$	62.5	°C/W

Thermal characteristics (TO-220F)

Parameter	Symbol	Max	Units
thermal resistance , Junction- Case	$R_{\theta JC}$	4.03	°C/W
thermal resistance , Junction-Ambient	$R_{\theta JA}$	80	°C/W

Note1: Pulse width limited by maximum junction temperature

Note2: L=20mH, VD_s=50V, Start T_J=25°C

Note3: ISD =4.8A, di/dt ≤100A/us, VDD≤BVDS, Start T_J=25°C

Note4: Pulse width tp≤300μs, δ≤2%

Electrical Characteristics (TC=25°C unless otherwise noted)

Parameter	Symbol	Test Conditions	Values			Units
			Min	Typ	Max	
Off Characteristics						
Drain-Source Breakdown Voltage	V_{DSS}	$V_{GS}=0V, I_D=250\mu A$	600		-	V
Bvdss Temperature Coefficient	$\frac{\Delta BV_{DSS}}{\Delta T_J}$	$I_D=250\mu A$, Reference 25°C	-	0.67	-	V/°C
Drain-Source Leakage Current	I_{DSS}	$V_{DS}=600V, V_{GS}=0V$ $T_J=125^\circ C$	-	-	1	μA
		$V_{DS}=480V, V_{GS}=0V$ $T_J=125^\circ C$	-	-	100	μA
Gate-Source Forward Leakage	$I_{GSS(F)}$	$V_{GS}=+30V$	-	-	100	nA
Gate-Source Reverse Leakage	$I_{GSS(R)}$	$V_{GS}=-30V$	-	-	- 100	nA
On Characteristics						
Drain- Source On- Resistance	$R_{DS(on)}$	$V_{GS}=10V, I_D=50A$	-	0.31	0.36	Ω
Gate Threshold Voltage	$V_{GS(th)}$	$V_{DS}=V_{GS}, I_D=250\mu A$	2.0	-	4.0	V
Dynamic Characteristics						
Gate resistance	R_g	f=1 MHz	-	10.5	-	m Ω
Input Capacitance	C_{iss}	$V_{DS}=25V,$ $V_{GS}=0,$ f=1 MHz	-	760	-	pF
Output Capacitance	C_{oss}		-	710	-	
Reverse Transfer Capacitance	C_{rss}		-	16	-	
Total Gate Charge	Q_g	$V_{DD}=480V,$ $I_D=4.8A,$ $V_{GS}=10V$	-	20.8	-	nC
Gate- Source charge	Q_{gs}		-	4.9	-	
Gate-Drain charge	Q_{gd}		-	7.3	-	
Switching Characteristics						
Turn- On Delay Time	$t_{d(on)}$	$V_{DD}=400V,$ $I_D=4.8A,$ $V_{GS}=10V,$ $R_G=5\Omega,$	-	11	-	ns
Rise Time	t_r		-	8	-	
Turn- Off Delay Time	$t_{d(off)}$		-	38	-	
Fall Time	t_f		-	7	-	
Source-Drain Diode Characteristics						
Continuous Source Current	I_S	TC=25 °C	-	-	11	A
Maximum Pulsed Current	I_{SM}		-	-	33	A
Diode Forward Voltage	V_{SD}	$I_S=4.8A$ $V_{GS}=0V$ (Note4)	-	-	1.2	V
Reverse Recovery Time	T_{rr}	$I_S=4.8A,$ $T_J=25^\circ C$	-	280	-	ns
Reverse Recovery Charge	Q_{rr}	dIF/dt=100A/us, VGS=0V	-	3080	-	nC

Characteristics Curves

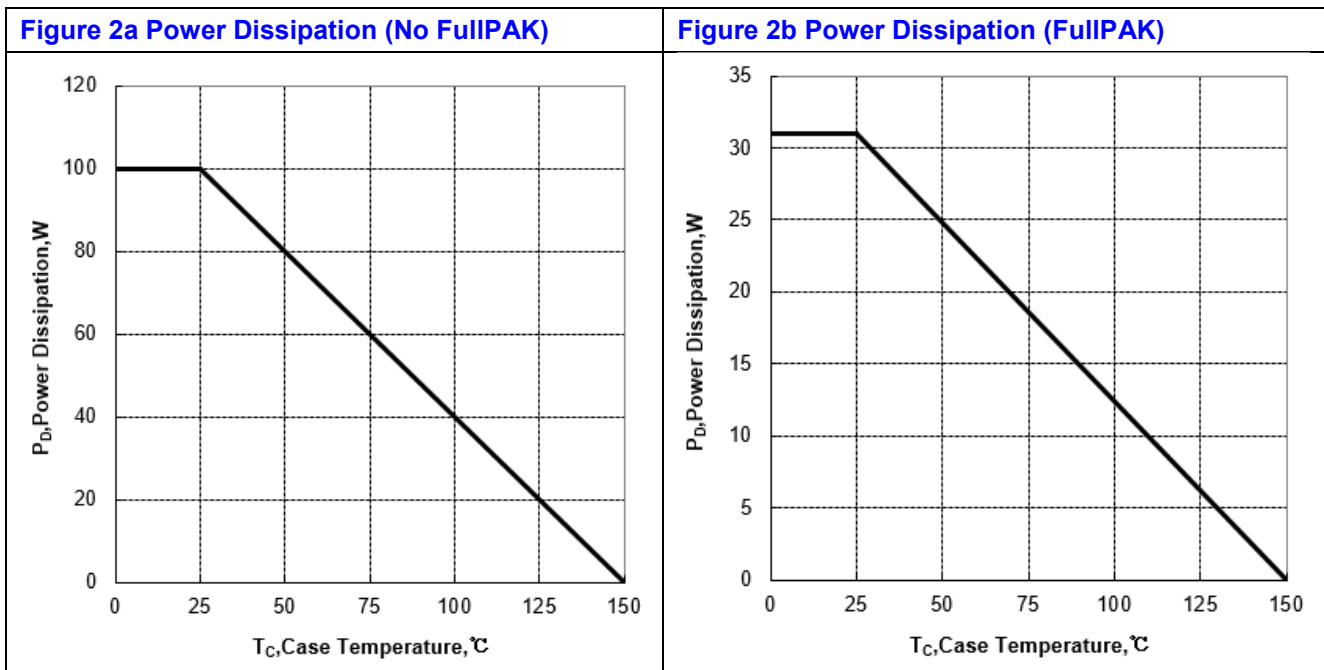
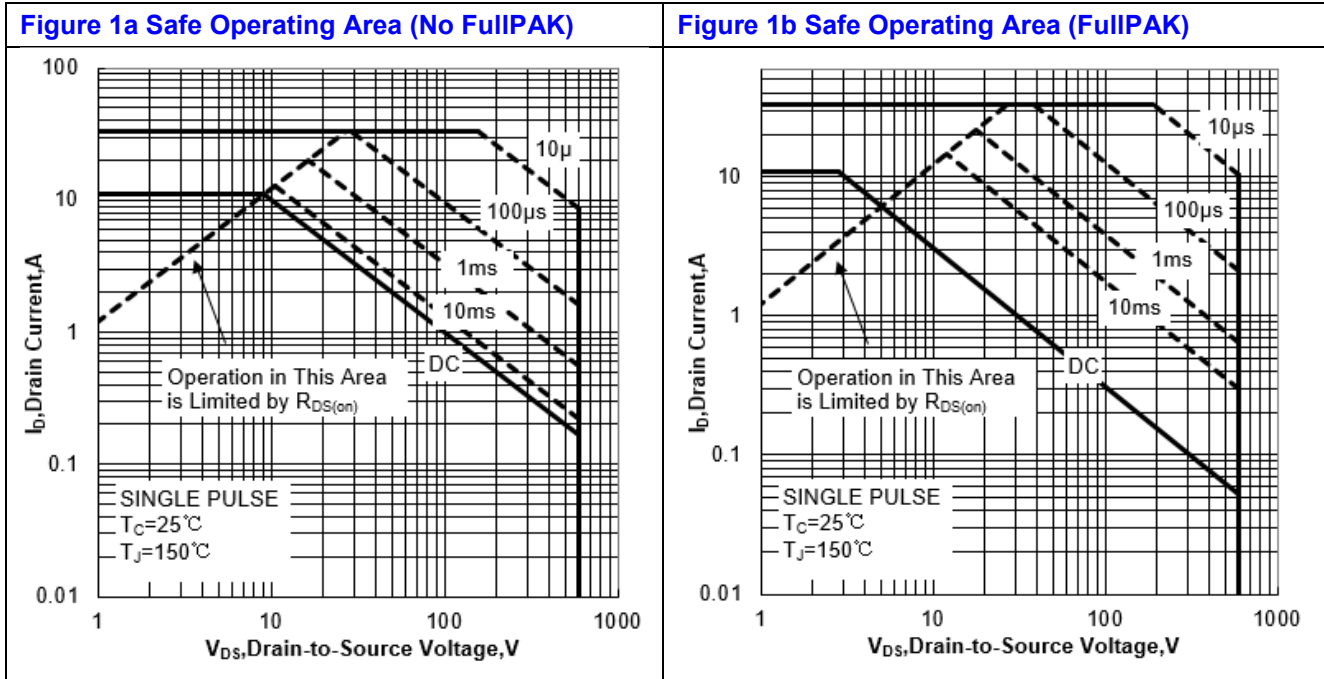

Figure 3a Max Thermal Impedance (No FullPAK)

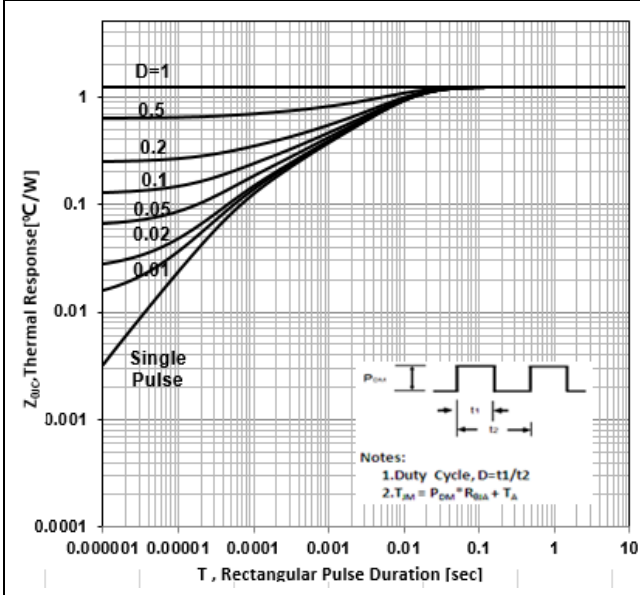

Figure 3b Max Thermal Impedance (FullPAK)

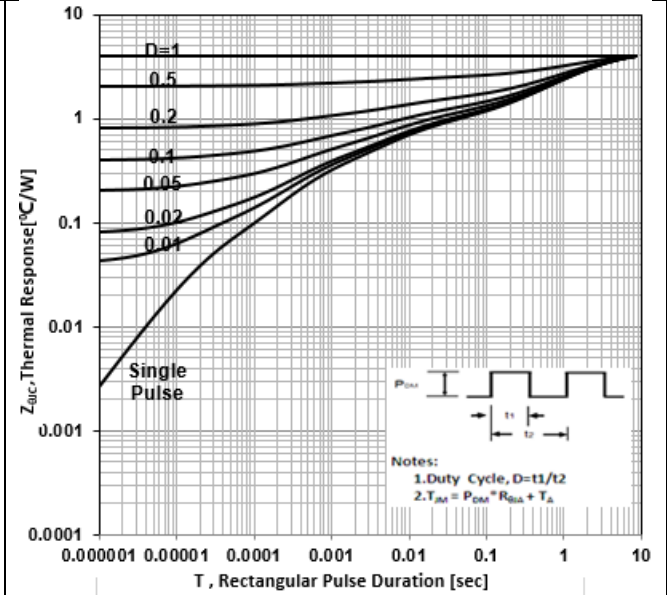

Figure 4 Typical Output Characteristics

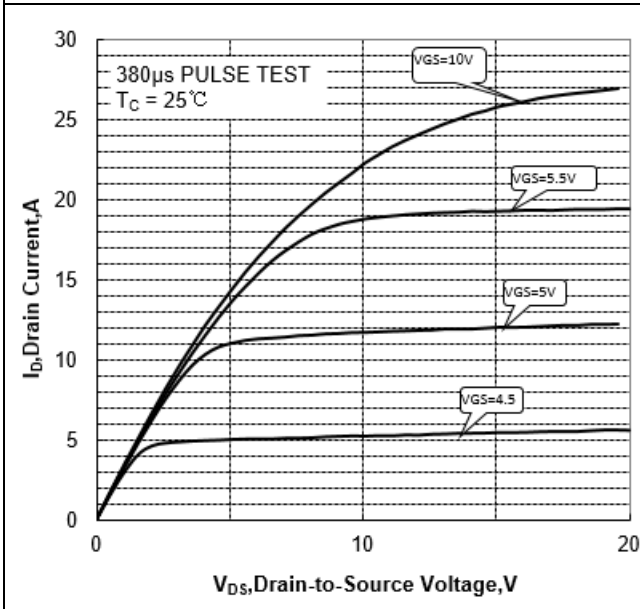

Figure 5 Typical Transfer Characteristics

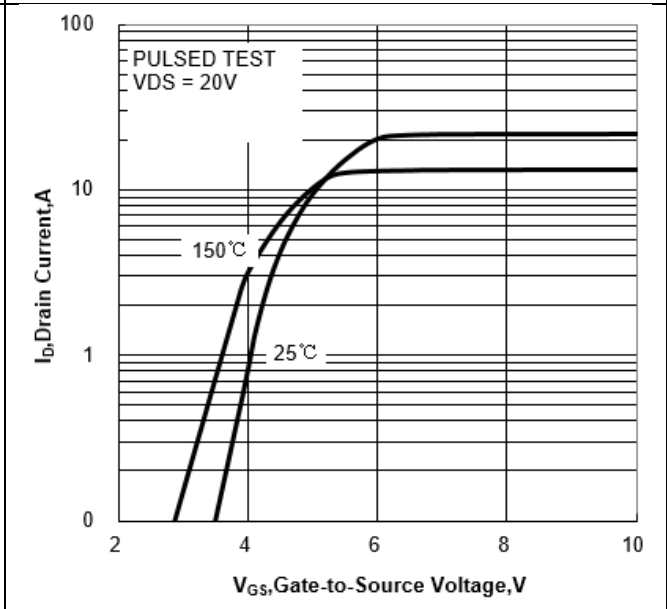

Figure 6 Typical Drain to Source ON Resistance vs Drain Current

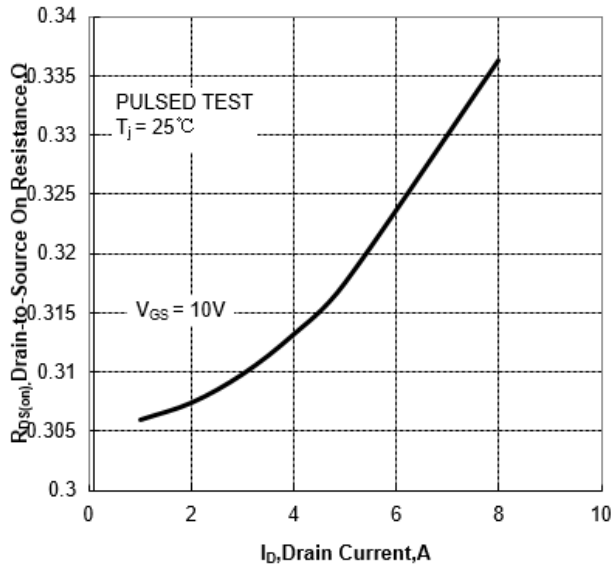

Figure 7 Typical Drain to Source on Resistance vs Junction Temperature

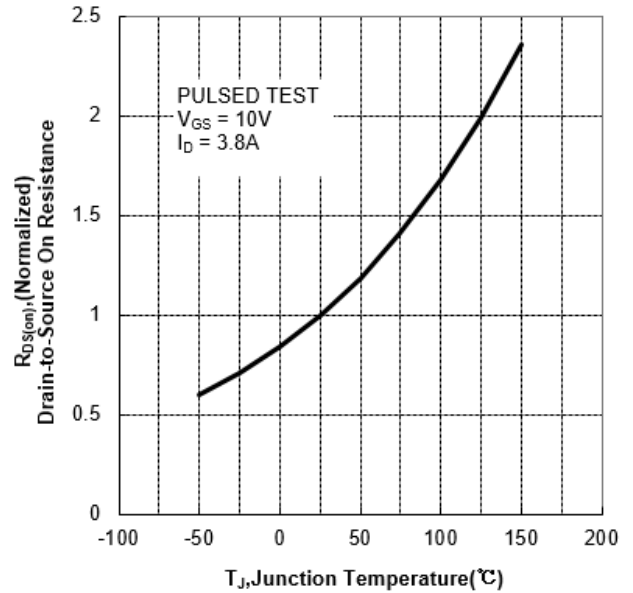

Figure 8 Typical Threshold Voltage vs Junction Temperature

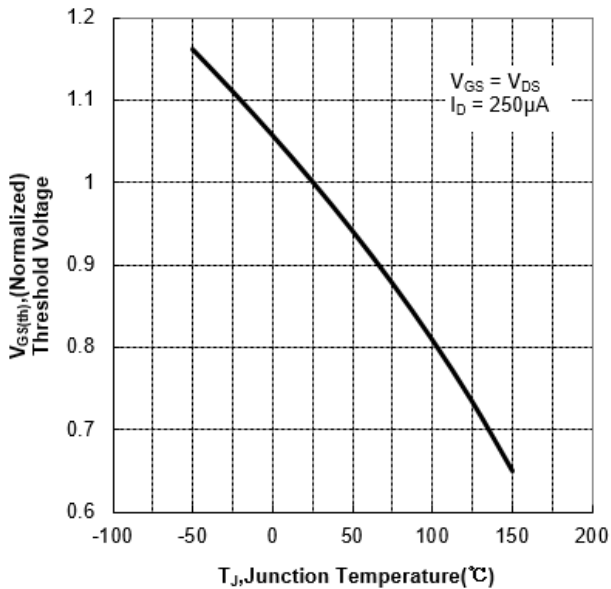

Figure 9 Typical Breakdown Voltage vs Junction Temperature

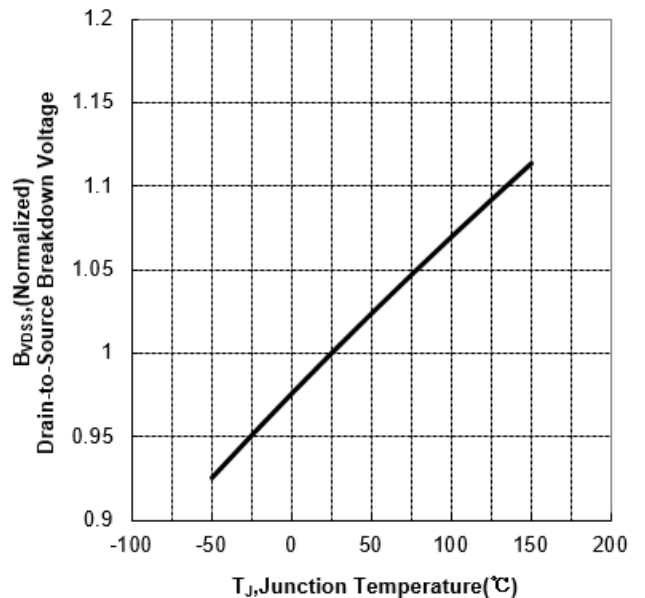

Figure 10 Typical Theshold Voltage vs Junction Temperature

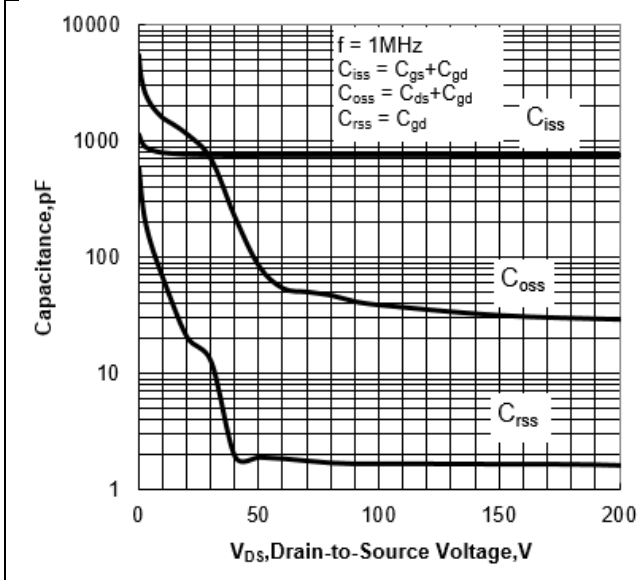
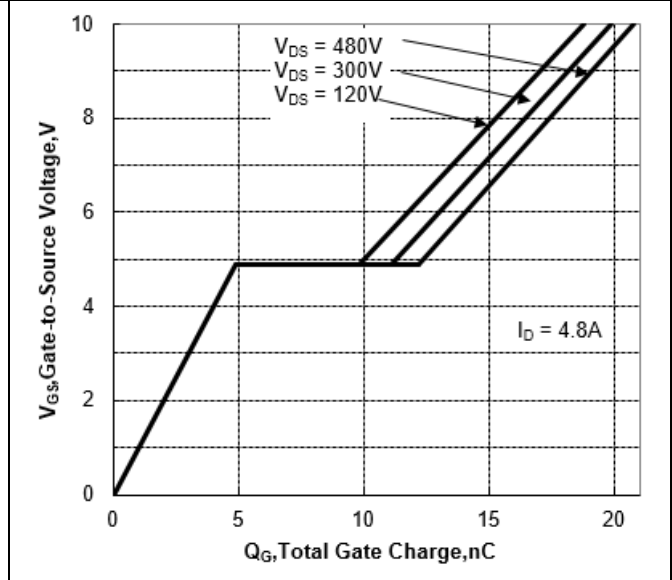

Figure 11 Typical Breakdown Voltage vs Junction Temperature



Test Circuit and Waveform

Figure 12 Gate Charge Test Circuit

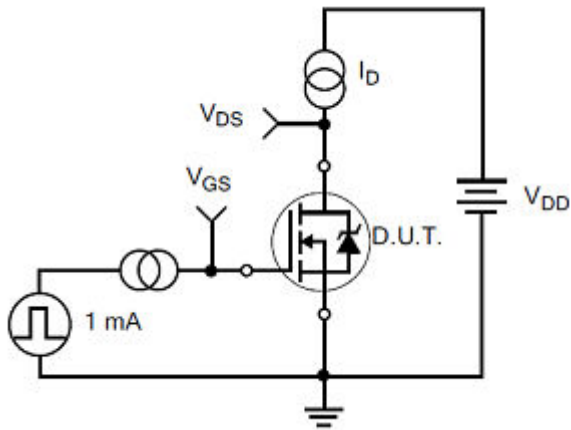

Figure 13 Gate Charge Waveforms

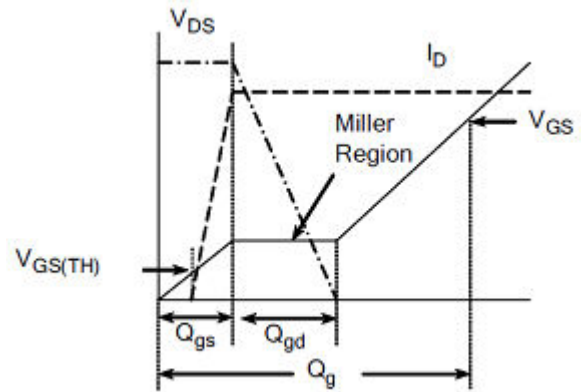

Figure 14 Resistive Switching Test Circuit

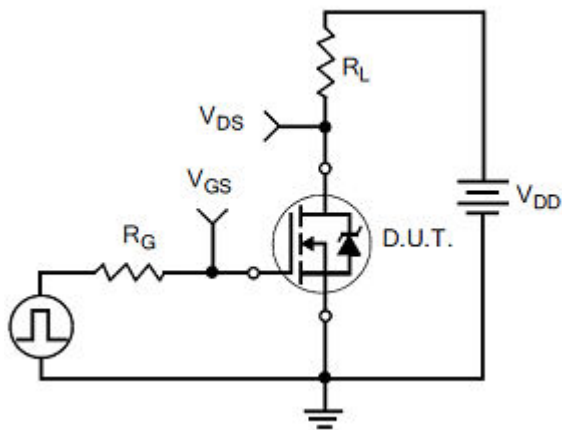

Figure 15 Resistive Switching Waveforms

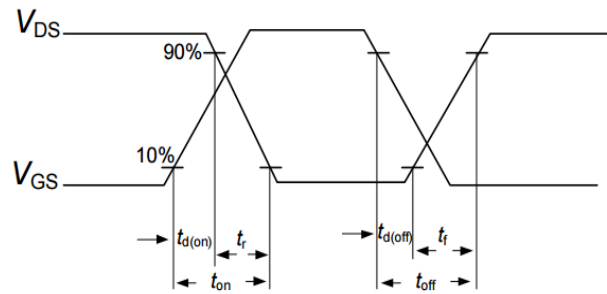

Figure 16 Diode Reverse Recovery Test Circuit

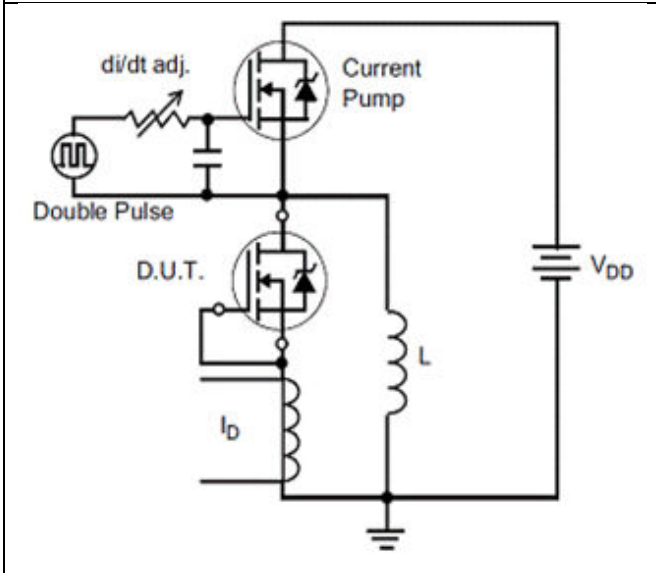

Figure 17 Diode Reverse Recovery Waveform

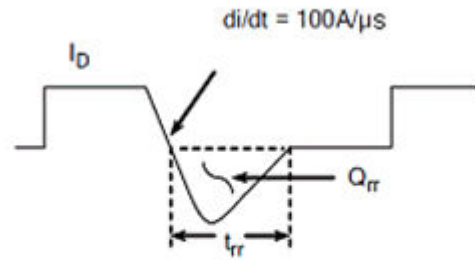

Figure 18 Unclamped Inductive Switching Test Circuit

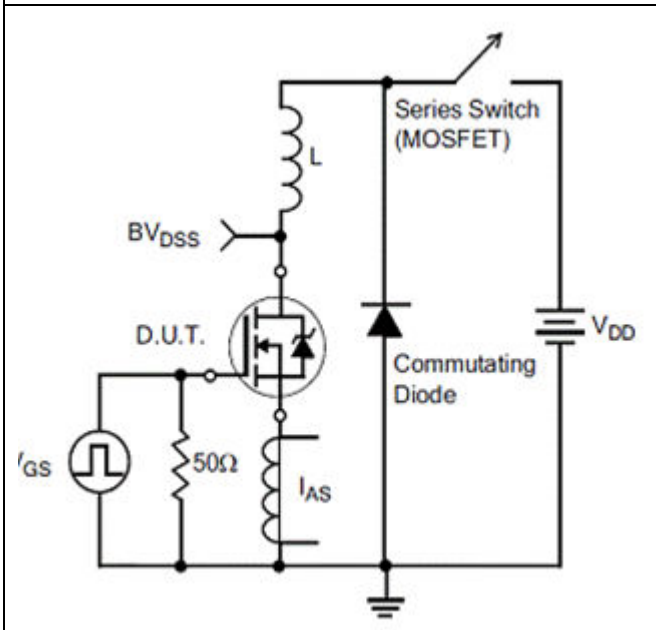
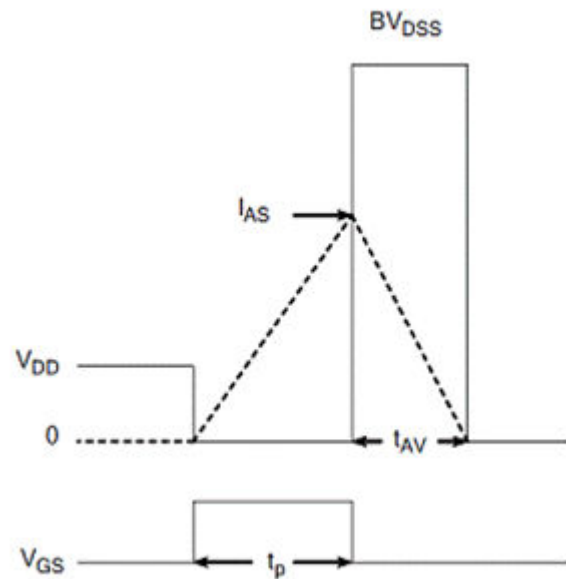
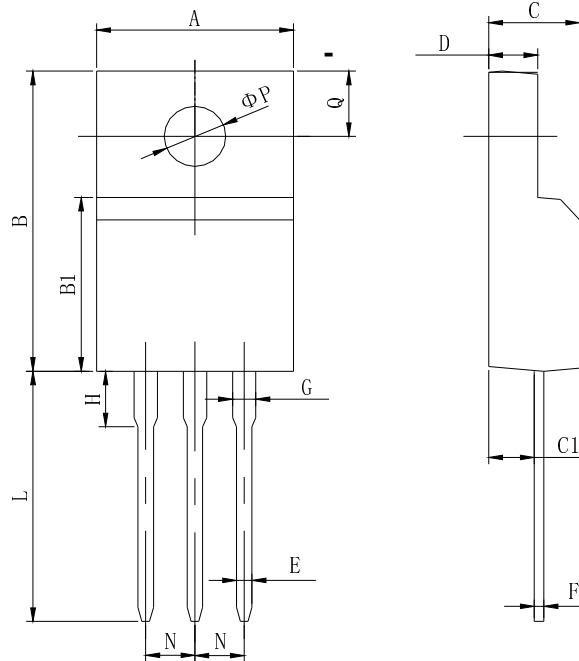

Figure 19 Unclamped Inductive Switching Waveform



Package Description



Items	Values(mm)	
	MIN	MAX
A	9.60	10.4
B	15.4	16.2
B1	8.90	9.50
C	4.30	4.90
C1	2.10	3.00
D	2.40	3.00
E	0.60	1.00
F	0.30	0.60
G	1.12	1.42
H	3.40	3.80
	1.60	2.90
L	12.0	14.0
N	2.34	2.74
Q	3.15	3.55
ϕP	2.90	3.30

TO-220F Package

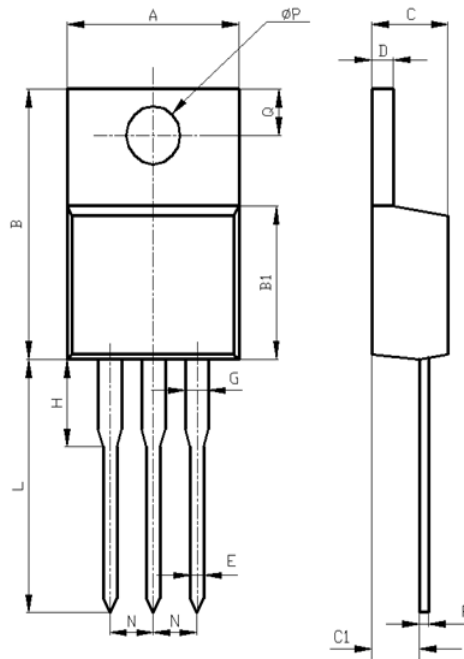

Items	Values(mm)	
	MIN	MAX
A	9.60	10.6
B	15.0	16.0
B1	8.90	9.50
C	4.30	4.80
C1	2.30	3.10
D	1.20	1.40
E	0.70	0.90
F	0.30	0.60
G	1.17	1.37
H	2.70	3.80
L	12.6	14.8
N	2.34	2.74
Q	2.40	3.00
Φ P	3.50	3.90

TO-220 Package

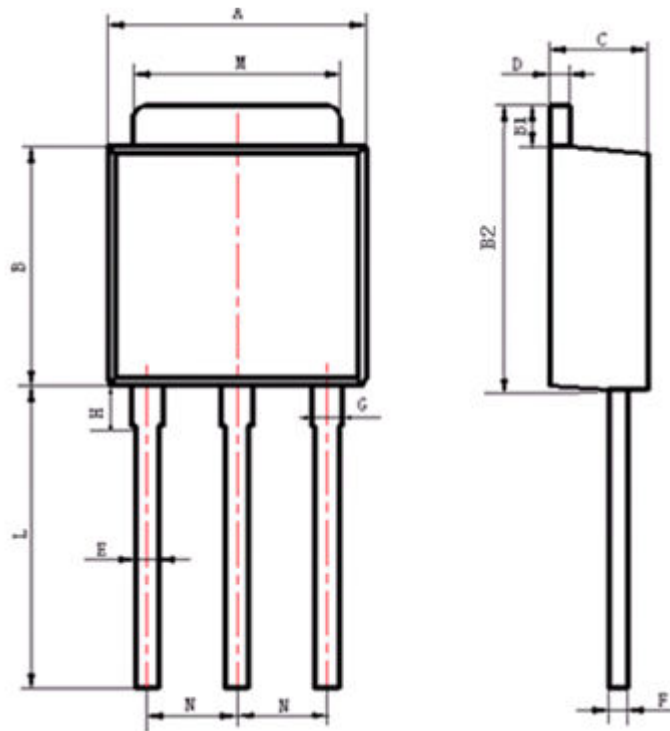

Items	Values(mm)	
	MIN	MAX
A	6.30	6.90
B	5.70	6.30
B1	1.00	1.20
B2	6.80	7.40
C	2.10	2.50
D	0.30	0.60
E	0.50	0.70
F	0.30	0.60
G	0.70	1.00
H	1.60	2.40
L	3.9	4.3
M	5.10	5.50
N	2.09	2.49

TO-251 Package

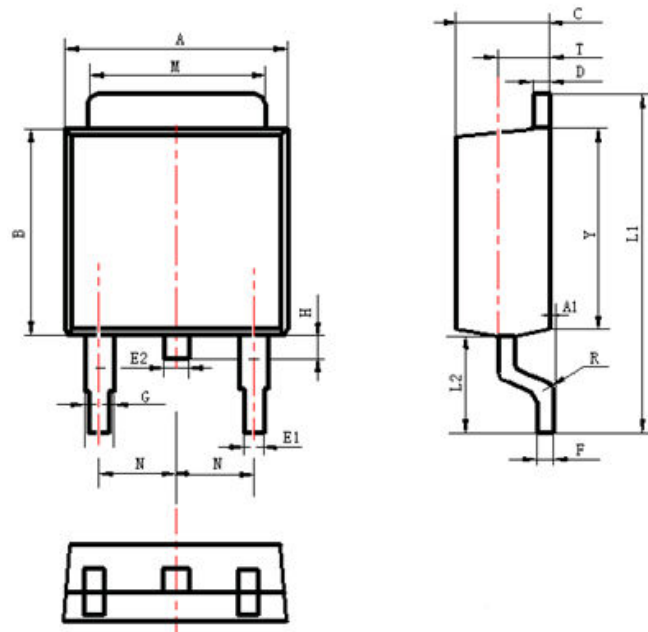

Items	Values(mm)	
	MIN	MAX
A	6.30	6.90
A1	0	0.13
B	5.70	6.30
C	2.10	2.50
D	0.30	0.60
E1	0.60	0.90
E2	0.70	1.00
F	0.30	0.60
G	0.70	1.20
L1	9.60	10.50
L2	2.70	3.10
H	0.60	1.00
M	5.10	5.50
N	2.09	2.49
R	0.3	
T	1.40	1.60
Y	5.10	6.30

TO-252 Package

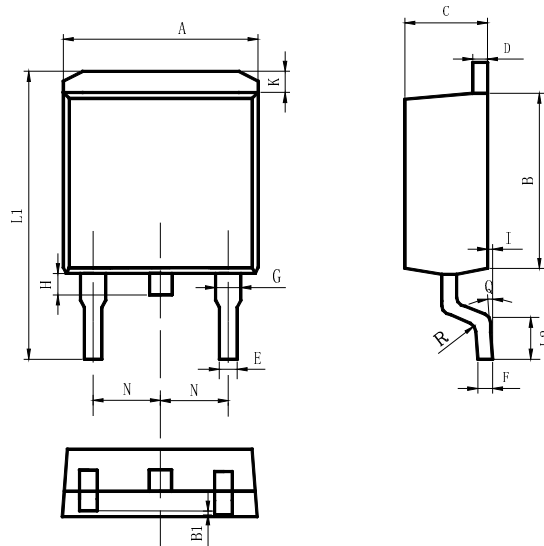

Items	Values(mm)	
	MIN	MAX
A	9.80	10.40
B	8.90	9.50
B1	0	0.10
C	4.40	4.80
D	1.16	1.37
E	0.70	0.95
F	0.30	0.60
G	1.07	1.47
H	1.30	1.80
K	0.95	1.37
L1	14.50	16.50
L2	1.60	2.30
I	0	0.2
Q	0°	8°
R	0.4	
N	2.39	2.69

TO-263 Package

NOTE:

1. Exceeding the maximum ratings of the device in performance may cause damage to the device, even the permanent failure, which may affect the dependability of the machine. Please do not exceed the absolute maximum ratings of the device when circuit designing.
2. When installing the heat sink, please pay attention to the torsional moment and the smoothness of the heat sink.
3. MOSFETs is the device which is sensitive to the static electricity, it is necessary to protect the device from being damaged by the static electricity when using it.
4. Shanghai Jerrett reserves the right to make changes in this specification sheet and is subject to change without prior notice.