

1. Description

JR4N90, the silicon N-channel Enhanced MOSFETs, is obtained by advanced MOSFET technology which reduce the conduction loss, improve switching performance and enhance the avalanche energy. The transistor is suitable device for SMPS, high speed switching and general purpose applications.

KEY CHARACTERISTICS

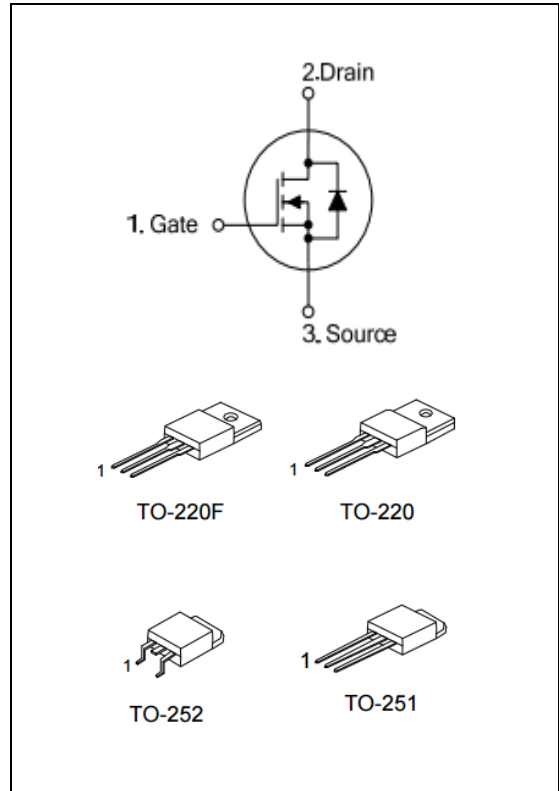
Parameter	Value	Unit
$V_{DS@Tj,max}$	900	V
I_D	4	A
$R_{DS(ON).Typ}$	2.6	Ω

FEATURES

- Fast Switching
- 100% avalanche tested
- Improved dv/dt capability
- RoHS product

APPLICATIONS

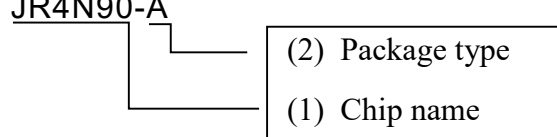
- High frequency switching mode power supply



ORDERING INFORMATION

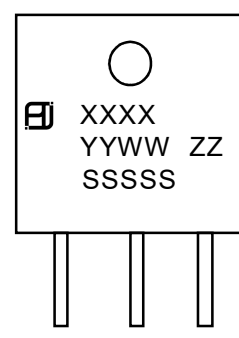
Ordering Codes	Package	Product Code	Packing
JR4N90-P	TO-220	JR4N90	Tube
JR4N90-A	TO-220F		Tube
JR4N90-U	TO-251		Tube
JR4N90-D	TO-252		Tape Reel

JR4N90-A



(2) Package type
(1) Chip name

(1) JR4N90:900V 4A
(2) A:TO-220F P:TO-220
U:TO-251 D: TO-252



XXXX: Product Code
YYWW: Year&Week
ZZ: Assembly Code
SSSSS: Lot Code

2. ABSOLUTE RATINGS

at $T_C = 25^\circ\text{C}$, unless otherwise specified

Symbol	Parameter	Rating	Units
V_{DSS}	Drain-to-Source Voltage	900	V
I_D	Continuous Drain Current	4	A
	Continuous Drain Current $T_C = 100^\circ\text{C}$	2.53	A
I_{DM}	Pulsed Drain Current(Note1)	16	A
V_{GS}	Gate-to-Source Voltage	± 30	V
E_{AS}	Single Pulse Avalanche Energy(Note2)	580	mJ
dv/dt	Peak Diode Recovery dv/dt(Note3)	4.5	V/ns
P_D	Power Dissipation TO-220	140	W
	Derating Factor above 25°C	1.12	W/ $^\circ\text{C}$
P_D	Power Dissipation TO-220F	47	W
	Derating Factor above 25°C	0.38	W/ $^\circ\text{C}$
P_D	Power Dissipation TO-251 TO-252	56	W
	Derating Factor above 25°C	0.45	W/ $^\circ\text{C}$
T_J, T_{stg}	Operating Junction and Storage Temperature Range	150, -55 to 150	$^\circ\text{C}$
T_L	Maximum Temperature for Soldering	300	$^\circ\text{C}$

3. Thermal characteristics

Thermal characteristics TO-220

Symbol	Parameter	RATINGS	Units
$R_{\theta JC}$	Junction-to-Case	0.89	$^\circ\text{C}/\text{W}$
$R_{\theta JA}$	Junction-to-Ambient	62.5	$^\circ\text{C}/\text{W}$

Thermal characteristics TO-220F

Symbol	Parameter	RATINGS	Units
$R_{\theta JC}$	Junction-to-Case	2.66	$^\circ\text{C}/\text{W}$
$R_{\theta JA}$	Junction-to-Ambient	62.5	$^\circ\text{C}/\text{W}$

Thermal characteristics TO-251/252

Symbol	Parameter	RATINGS	Units
$R_{\theta JC}$	Junction-to-Case	2.23	$^\circ\text{C}/\text{W}$
$R_{\theta JA}$	Junction-to-Ambient	100	$^\circ\text{C}/\text{W}$

4. Electrical Characteristics

 at $T_c = 25^\circ\text{C}$, unless otherwise specified

OFF Characteristics						
Symbol	Parameter	Test Conditions	Values			Units
			Min.	Typ.	Max.	
V_{DSS}	Drain to Source Breakdown Voltage	$V_{GS}=0V$, $I_D=250\mu A$	900	--	--	V
$\frac{\Delta V_{DSS}}{\Delta T_J}$	Bvdss Temperature Coefficient	$I_D=250\mu A$, Reference 25°C	--	1.05	--	$V/^\circ\text{C}$
I_{DSS}	Drain to Source Leakage Current	$V_{DS} = 900V$, $V_{GS} = 0V$, $T_J = 25^\circ\text{C}$	--	--	10	μA
		$V_{DS} = 720V$, $V_{GS} = 0V$, $T_J = 125^\circ\text{C}$	--	--	100	μA
$I_{GSS(F)}$	Gate to Source Forward Leakage	$V_{GS} = +30V$	--	--	100	nA
$I_{GSS(R)}$	Gate to Source Reverse Leakage	$V_{GS} = -30V$	--	--	-100	nA

ON Characteristics						
Symbol	Parameter	Test Conditions	Values			Units
			Min.	Typ.	Max.	
$R_{DS(ON)}$	Drain-to-Source On-Resistance	$V_{GS}=10V$, $I_D=2A(\text{Note4})$	--	2.6	3.0	Ω
$V_{GS(TH)}$	Gate Threshold Voltage	$V_{DS} = V_{GS}$, $I_D = 250\mu A(\text{Note4})$	3.0	--	4.5	V

Dynamic Characteristics						
Symbol	Parameter	Test Conditions	Values			Units
			Min.	Typ.	Max.	
R_g	Gate resistance	$f = 1.0\text{MHz}$	--	2.5	--	Ω
C_{iss}	Input Capacitance	$V_{GS} = 0V$ $V_{DS} = 25V$ $f = 1.0\text{MHz}$	--	900	--	PF
C_{oss}	Output Capacitance		--	70	--	
C_{rss}	Reverse Transfer Capacitance		--	3	--	

Switching Characteristics						
Symbol	Parameter	Test Conditions	Values			Units
			Min.	Typ.	Max.	
$t_{d(ON)}$	Turn-on Delay Time	ID =4A VDD = 450V VGS = 10V RG =20Ω	--	25	--	ns
t_r	Rise Time		--	30	--	
$t_{d(OFF)}$	Turn-Off Delay Time		--	45	--	
t_f	Fall Time		--	25	--	
Q_g	Total Gate Charge	ID =4A VDD =720V VGS = 10V	--	17	--	nC
Q_{gs}	Gate to Source Charge		--	5	--	
Q_{gd}	Gate to Drain ("Miller")Charge		--	7	--	

Source-Drain Diode Characteristics						
Symbol	Parameter	Test Conditions	Values			Units
			Min.	Typ.	Max.	
I_S	Continuous Source Current (Body Diode)	TC=25 °C	--	--	4	A
I_{SM}	Maximum Pulsed Current (Body Diode)		--	--	16	A
V_{SD}	Diode Forward Voltage	IS=4A, VGS=0V(Note4)	--	--	1.2	V
T_{rr}	Reverse Recovery Time	IS=4A, Tj = 25°C dIF/dt=100A/us, VGS=0V	--	450	--	ns
Q_{rr}	Reverse Recovery Charge		--	2880	--	nC
I_{rrm}	Reverse Recovery Current		--	12.8	--	A

Note1: Pulse width limited by maximum junction temperature

Note2: L=67mH, VD_s=50V, Start T_J=25°C

Note3: ISD =4A, di/dt ≤100A/us, VDD≤BVDS, Start T_J=25°C

Note4: Pulse width tp≤300μs, δ≤2%



5.

Figure 1a Safe Operating Area (TO-220)

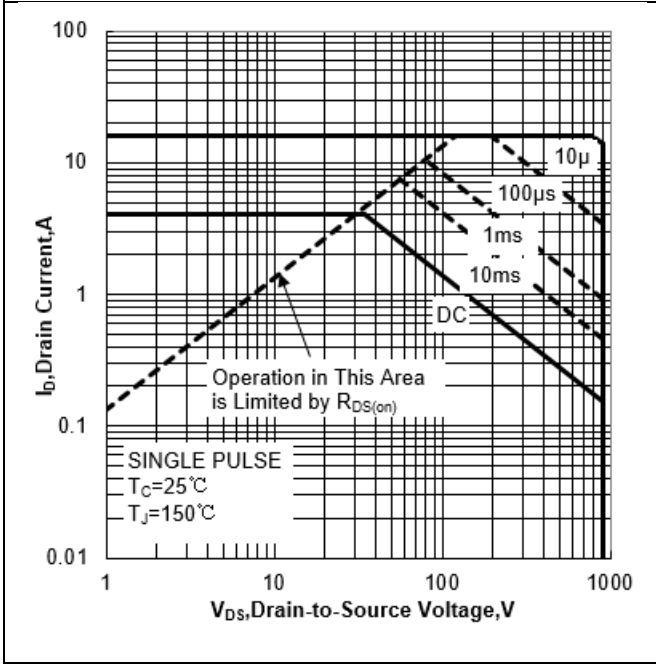


Figure 1b Safe Operating Area (TO-220F)

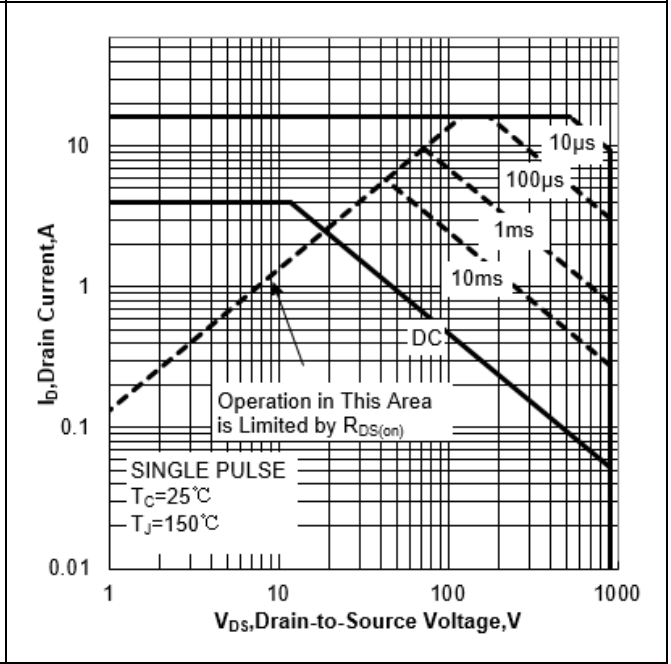


Figure 1c Safe Operating Area (TO-251\TO-252)

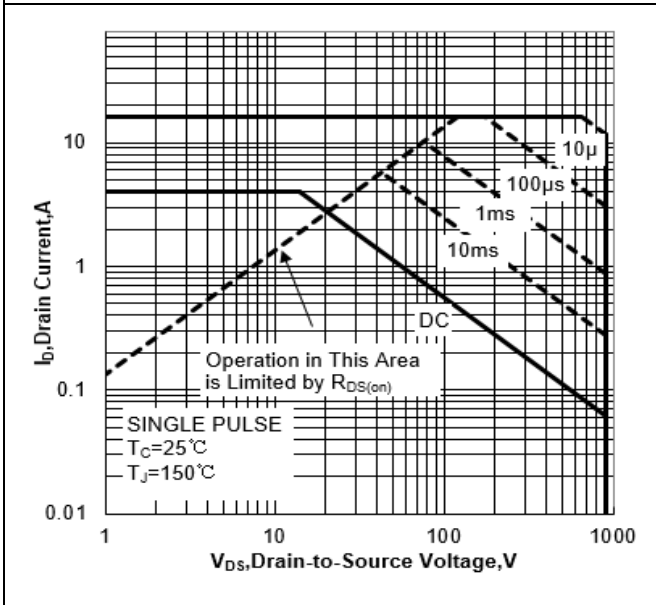


Figure 2a Power Dissipation (TO-220)

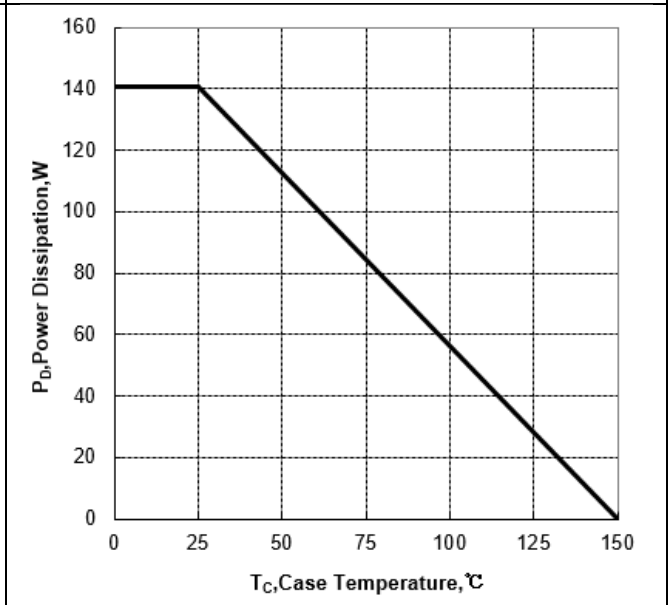




Figure 2c Power Dissipation (TO-220F)

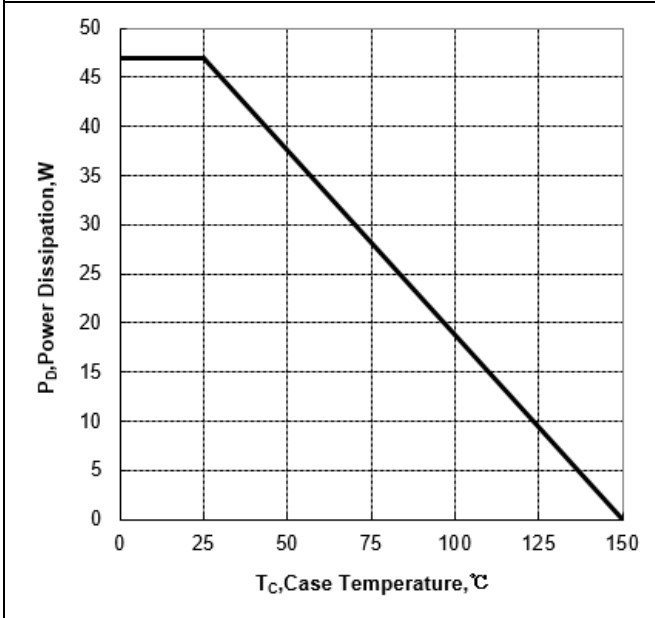


Figure 2c Power Dissipation (TO-251\TO-252)

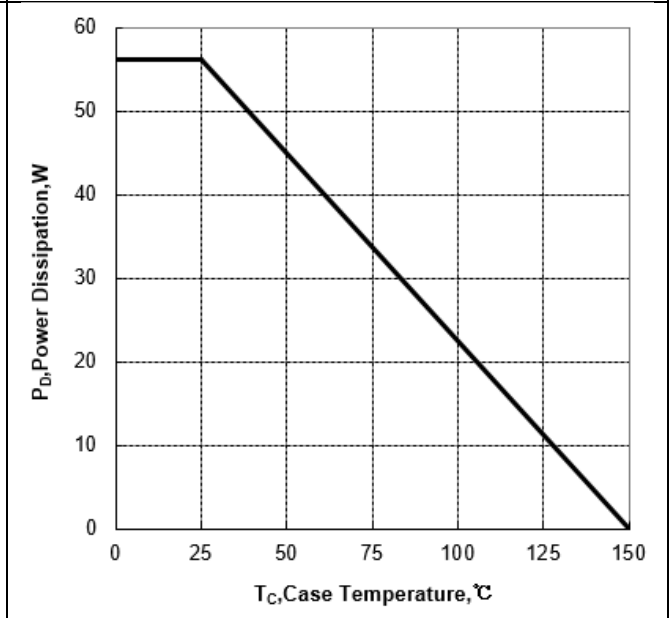


Figure 3a Thermal Impedance (TO-220)

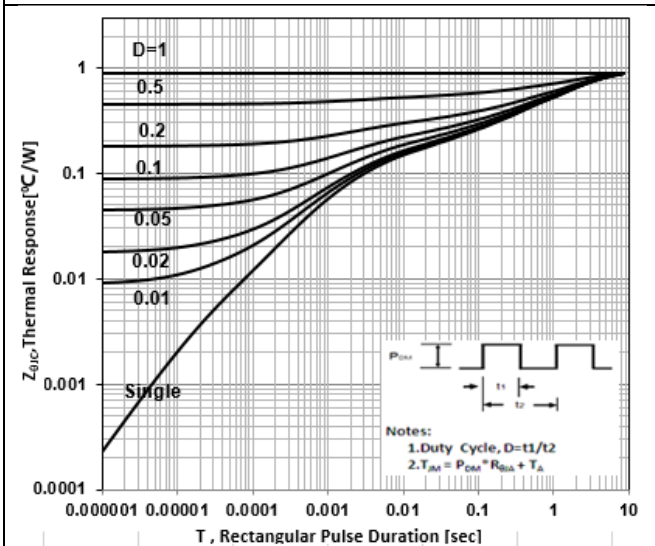


Figure 3b Thermal Impedance (TO-220F)

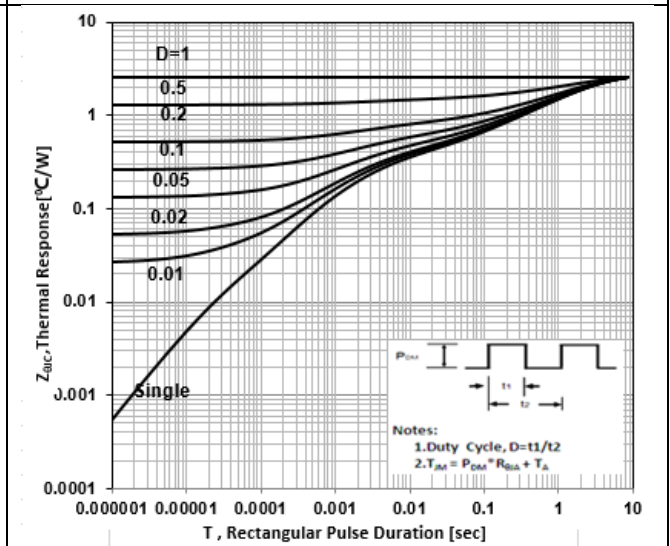




Figure 3c Thermal Impedance (TO-251\TO-252)

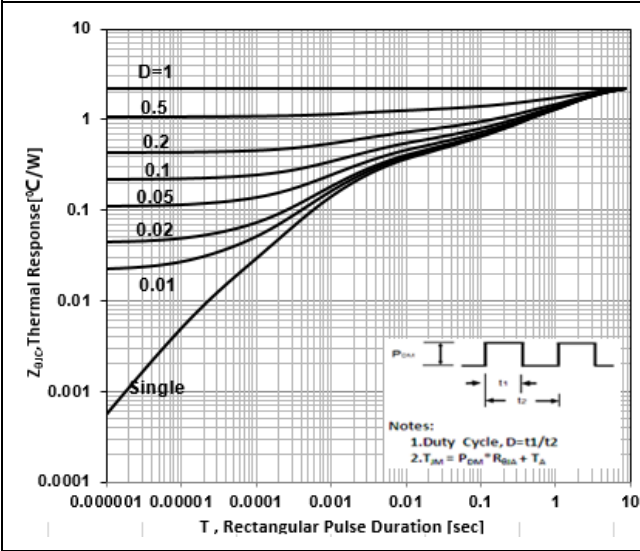


Figure 4 Maximum Continuous Drain Current

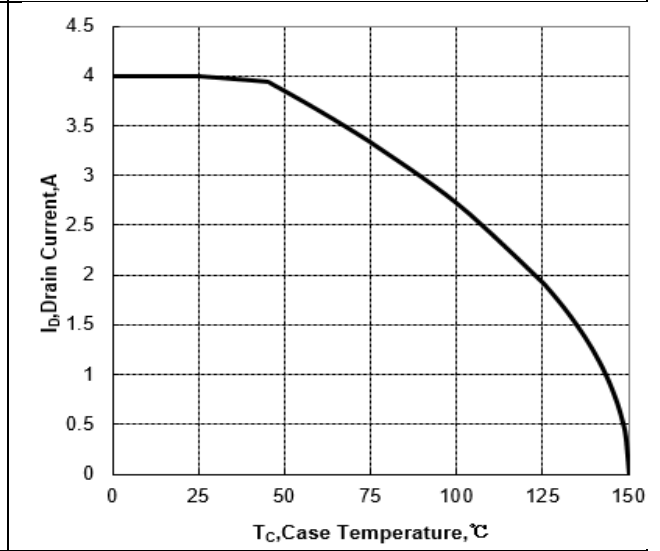


Figure 4 Typical Output Characteristics

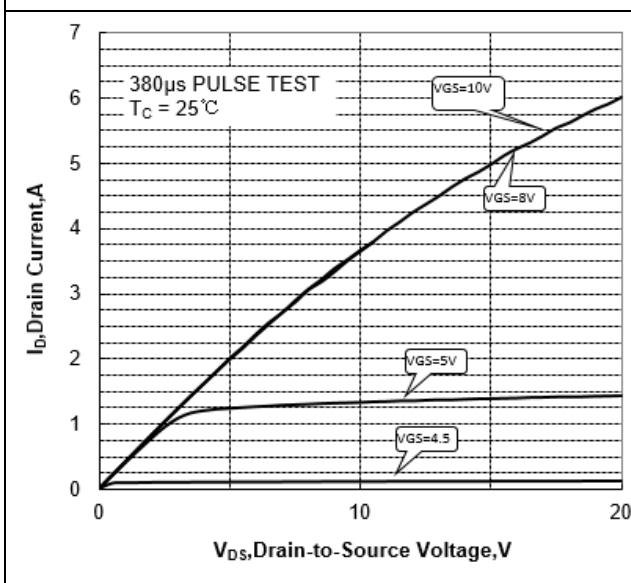


Figure 5 Typical Transfer Characteristics

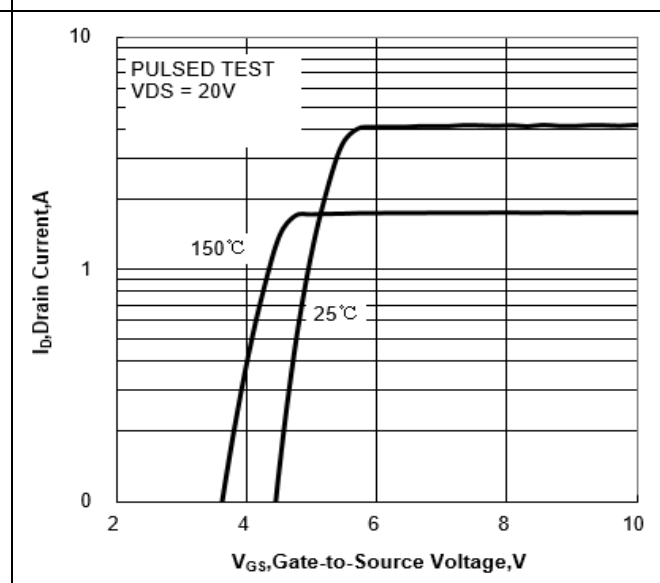




Figure 6 Typical Drain to Source ON Resistance vs Drain Current

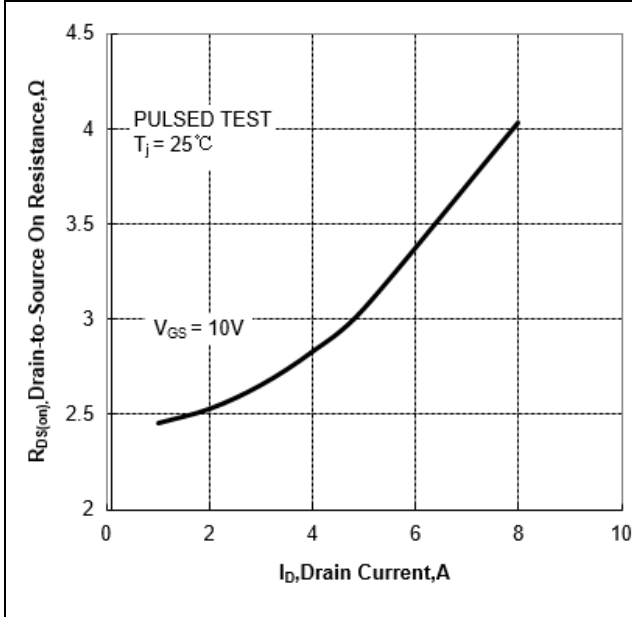


Figure 7 Typical Drain to Source on Resistance vs Junction Temperature

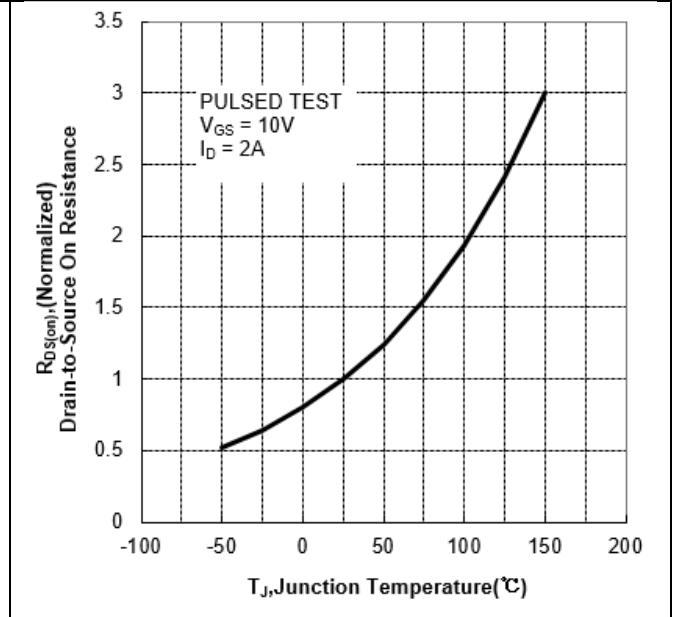


Figure 8 Typical Theshold Voltage vs Junction Temperature

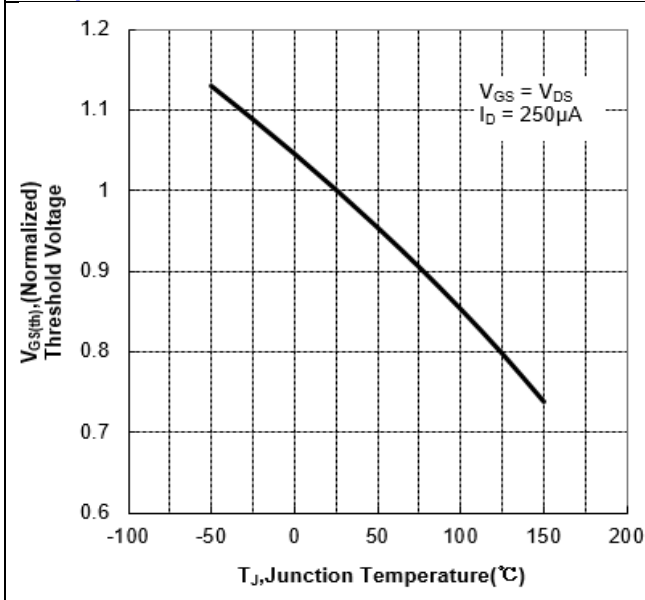


Figure 9 Typical Breakdown Voltage vs Junction Temperature

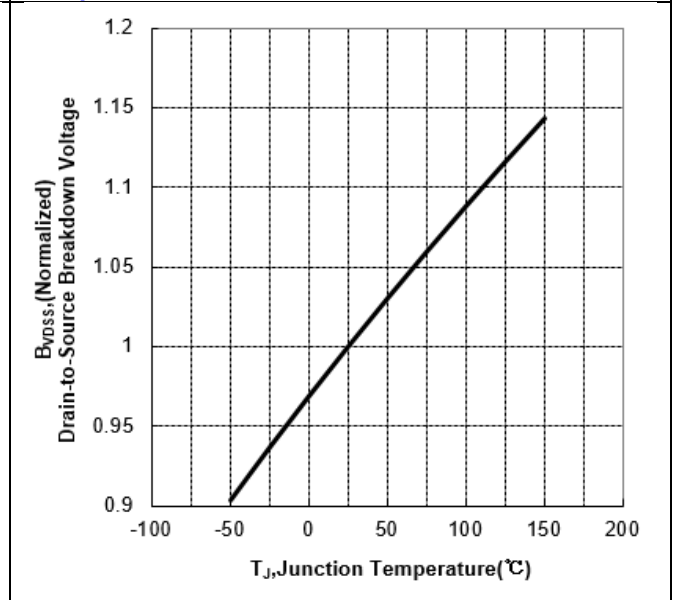




Figure 10 Typical Theshold Voltage vs Junction Temperature

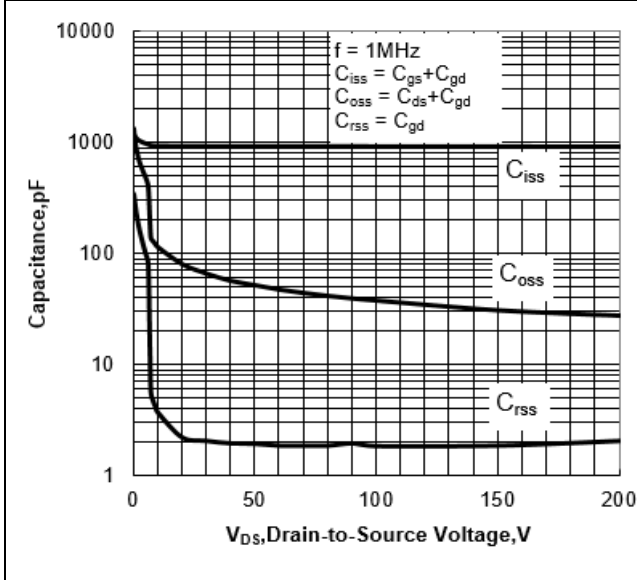
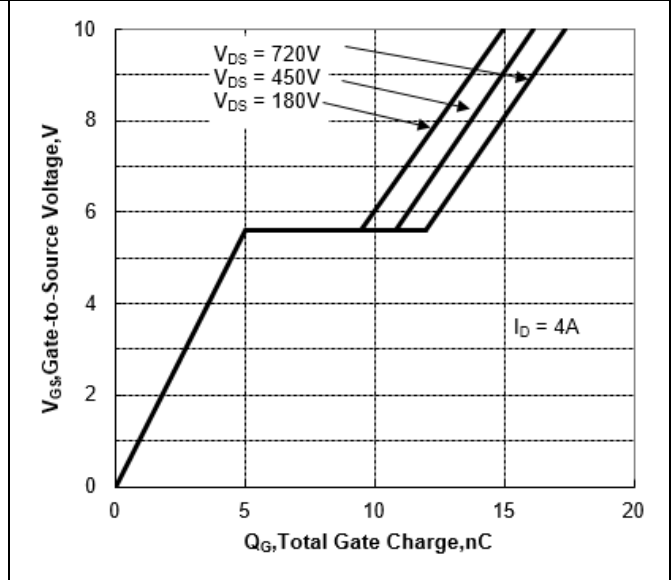


Figure 11 Typical Breakdown Voltage vs Junction Temperature



6. Test Circuit and Waveform

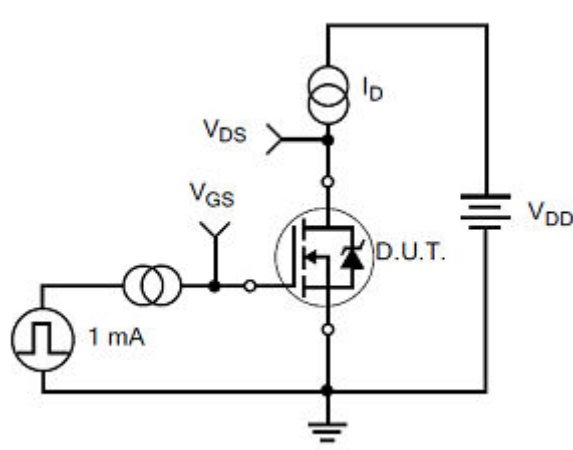
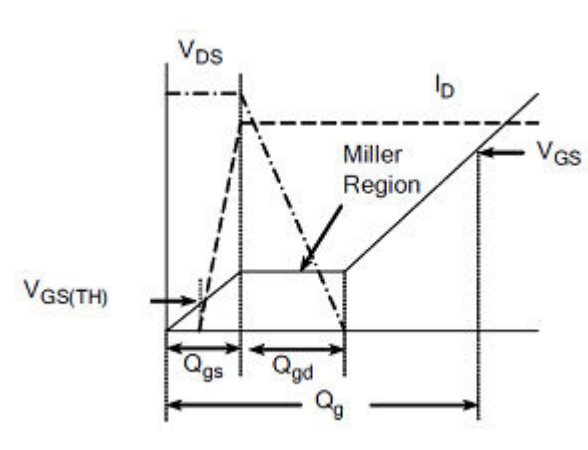
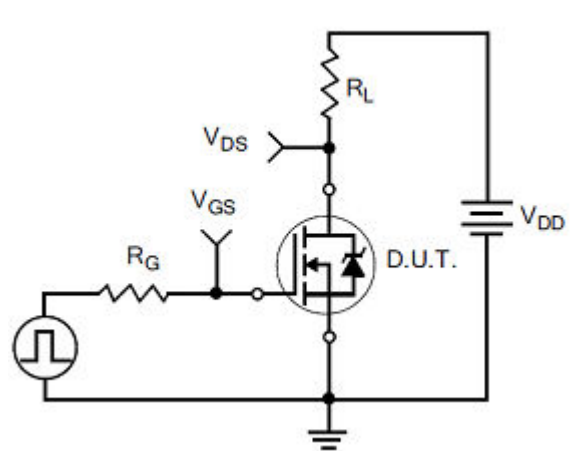
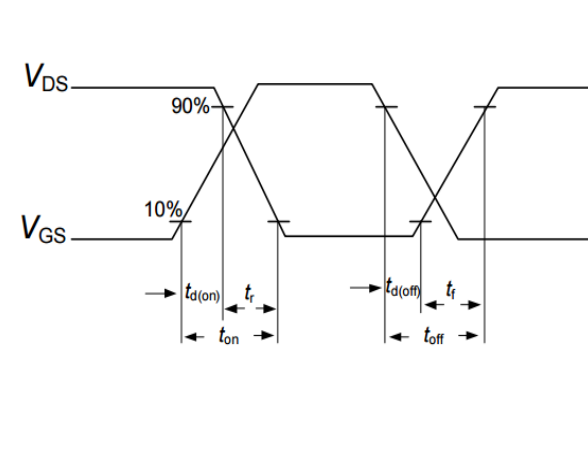
<p>Figure 12 Gate Charge Test Circuit</p> 	<p>Figure 13 Gate Charge Waveforms</p> 
<p>Figure 14 Resistive Switching Test Circuit</p> 	<p>Figure 15 Resistive Switching Waveforms</p> 

Figure 16 Diode Reverse Recovery Test Circuit

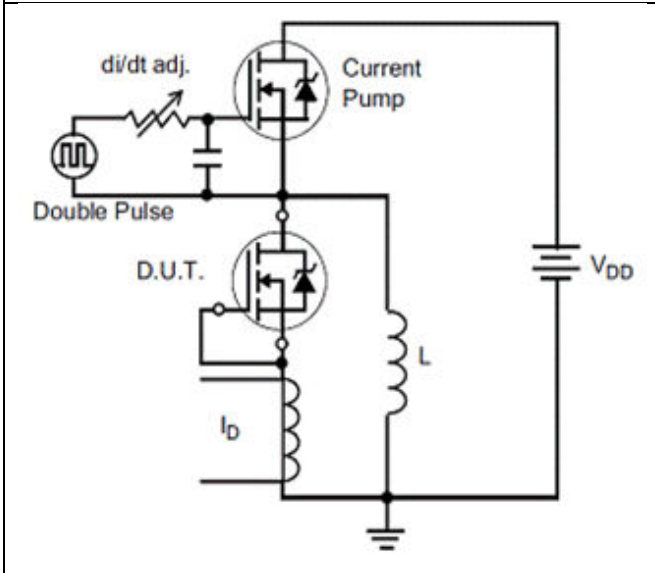


Figure 17 Diode Reverse Recovery Waveform

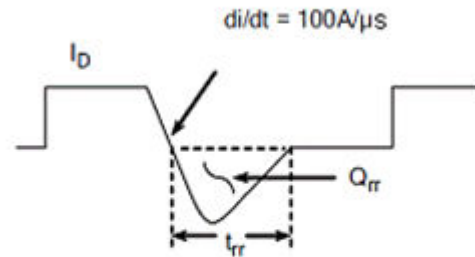


Figure 18 Unclamped Inductive Switching Test Circuit

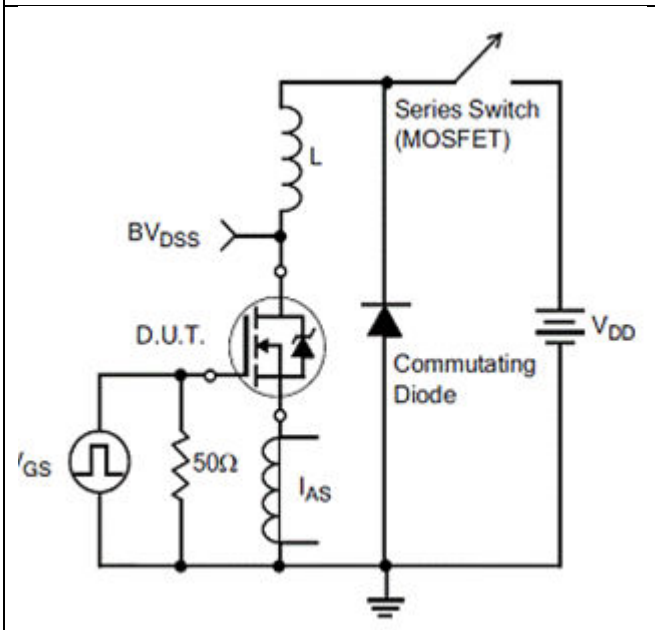
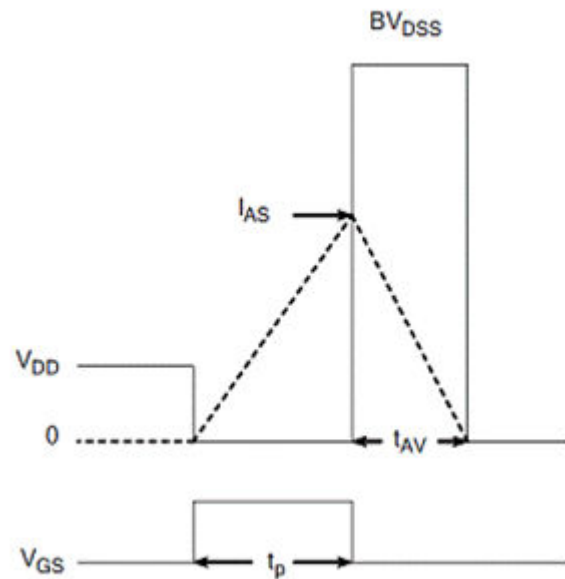
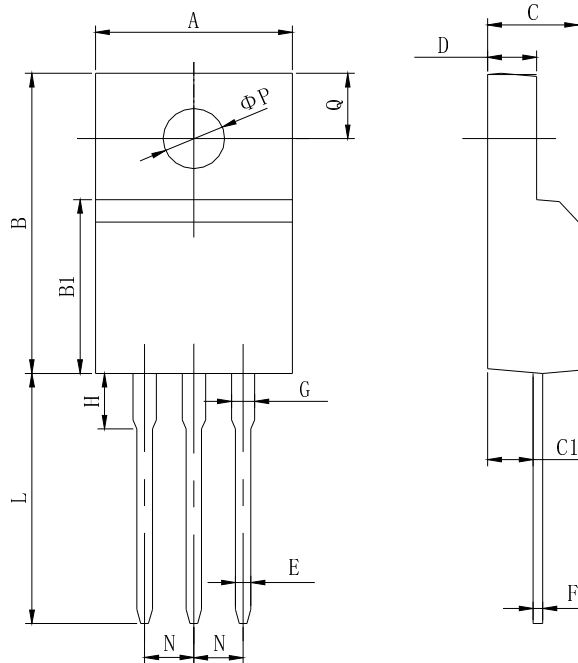


Figure 19 Unclamped Inductive Switching Waveform

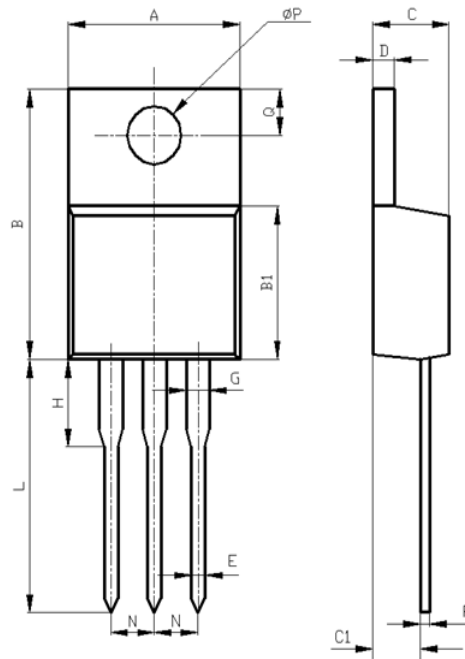


7. Package Description



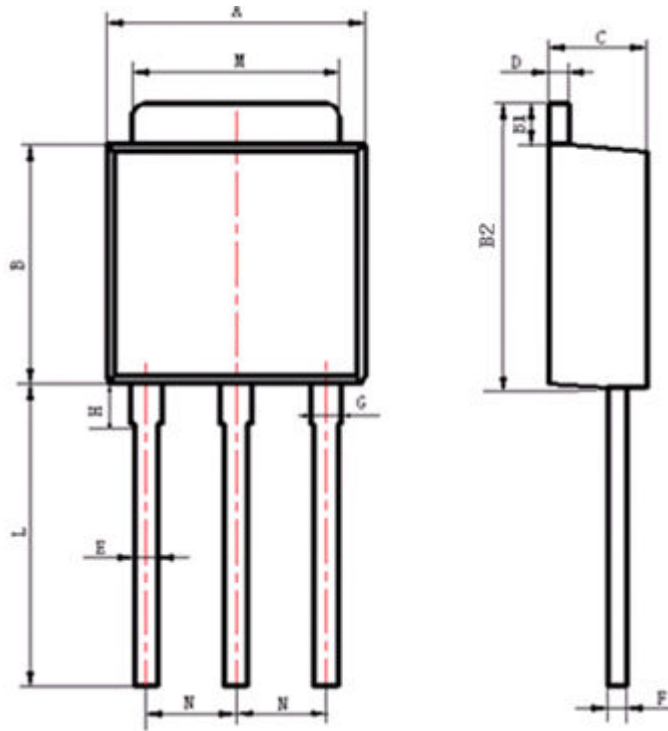
Items	Values(mm)	
	MIN	MAX
A	9.60	10.4
B	15.4	16.2
B1	8.90	9.50
C	4.30	4.90
C1	2.10	3.00
D	2.40	3.00
E	0.60	1.00
F	0.30	0.60
G	1.12	1.42
H	3.40	3.80
	1.60	2.90
L	12.0	14.0
N	2.34	2.74
Q	3.15	3.55
ϕP	2.90	3.30

TO-220F Package



Items	Values(mm)	
	MIN	MAX
A	9.60	10.6
B	15.0	16.0
B1	8.90	9.50
C	4.30	4.80
C1	2.30	3.10
D	1.20	1.40
E	0.70	0.90
F	0.30	0.60
G	1.17	1.37
H	2.70	3.80
L	12.6	14.8
N	2.34	2.74
Q	2.40	3.00
ϕP	3.50	3.90

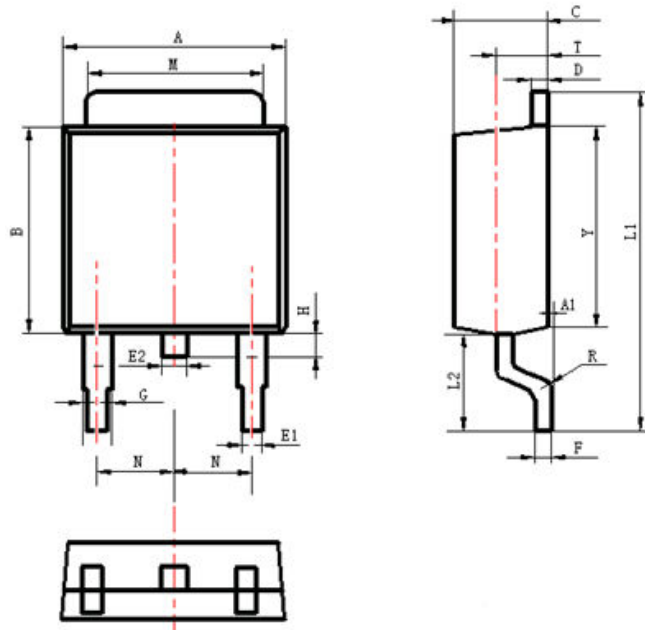
TO-220 Package



Items	Values(mm)	
	MIN	MAX
A	6.30	6.90
B	5.70	6.30
B1	1.00	1.20
B2	6.80	7.40
C	2.10	2.50
D	0.30	0.60
E	0.50	0.70
F	0.30	0.60
G	0.70	1.00
H	1.60	2.40
L*	3.9	4.3
M	5.10	5.50
N	2.09	2.49

*: adjustable

TO-251 Package



Items	Values(mm)	
	MIN	MAX
A	6.30	6.90
A1	0	0.13
B	5.70	6.30
C	2.10	2.50
D	0.30	0.60
E1	0.60	0.90
E2	0.70	1.00
F	0.30	0.60
G	0.70	1.20
L1	9.60	10.50
L2	2.70	3.10
H	0.60	1.00
M	5.10	5.50
N	2.09	2.49
R	0.3	
T	1.40	1.60
Y	5.10	6.30

TO-252 Package



NOTE:

1. Exceeding the maximum ratings of the device in performance may cause damage to the device, even the permanent failure, which may affect the dependability of the machine. Please do not exceed the absolute maximum ratings of the device when circuit designing.
2. When installing the heat sink, please pay attention to the torsional moment and the smoothness of the heat sink.
3. MOSFETs is the device which is sensitive to the static electricity, it is necessary to protect the device from being damaged by the static electricity when using it.
4. Shanghai Jerrett reserves the right to make changes in this specification sheet and is subject to change without prior notice.