

## 1. Description

JR10N65A, the silicon N-channel Enhanced MOSFETs, is obtained by advanced MOSFET technology which reduce the conduction loss, improve switching performance and enhance the avalanche energy. The transistor is suitable device for SMPS, high speed switching and general purpose applications.

### KEY CHARACTERISTICS

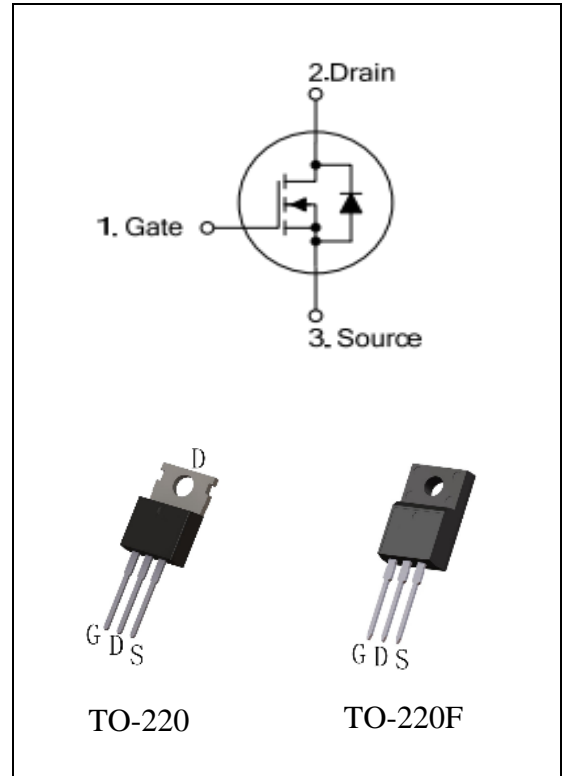
Parameter	Value	Unit
$V_{DS}$	650	V
$I_D$	10	A
$R_{DS(ON).Typ}$	0.87	$\Omega$

### FEATURES

- Fast Switching
- Low  $C_{rss}$
- 100% avalanche tested
- Improved  $dv/dt$  capability
- RoHS product

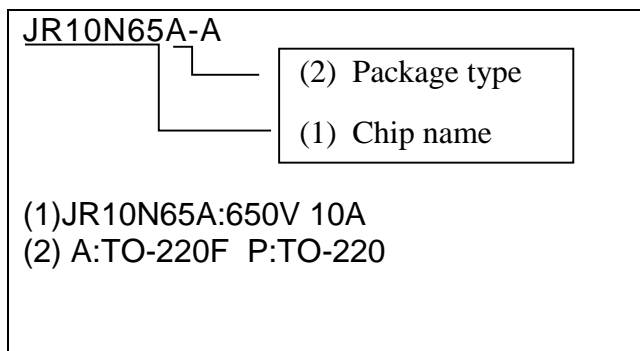
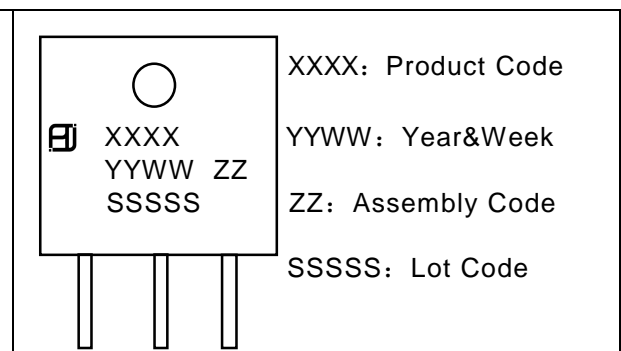
### APPLICATIONS

- High frequency switching mode power supply



### ORDERING INFORMATION

Ordering Codes	Package	Product Code	Packing
JR10N65A-P	TO-220	10N65A	Tube
JR10N65A-A	TO-220F		Tube

<p>JR10N65A-A</p>  <p>(1)JR10N65A:650V 10A (2) A:TO-220F P:TO-220</p>	 <p>XXXX: Product Code YYWW: Year&amp;Week ZZ: Assembly Code SSSSS: Lot Code</p>
--	--

## 2. ABSOLUTE RATINGS

at  $T_C = 25^\circ\text{C}$ , unless otherwise specified

Symbol	Parameter	Rating	Units
$V_{DSS}$	Drain-to-Source Voltage	650	V
$I_D$	Continuous Drain Current	10	A
	Continuous Drain Current $T_C = 100^\circ\text{C}$	6.6	A
$I_{DM}$	Pulsed Drain Current(Note1)	40	A
$V_{GS}$	Gate-to-Source Voltage	$\pm 30$	V
$E_{AS}$	Single Pulse Avalanche Energy(Note2)	640	mJ
$dv/dt$	Peak Diode Recovery $dv/dt$ (Note3)	5.0	V/ns
$P_D$	Power Dissipation TO-220	156	W
	Derating Factor above $25^\circ\text{C}$	1.25	W/ $^\circ\text{C}$
$P_D$	Power Dissipation TO-220F	45	W
	Derating Factor above $25^\circ\text{C}$	0.36	W/ $^\circ\text{C}$
$T_J, T_{stg}$	Operating Junction and Storage Temperature Range	150, $-55$ to 150	$^\circ\text{C}$
$T_L$	Maximum Temperature for Soldering	300	$^\circ\text{C}$

## 3. Thermal characteristics

### Thermal characteristics (No FullPAK) TO-220

Symbol	Parameter	RATINGS	Units
$R_{\theta JC}$	Junction-to-Case	0.8	$^\circ\text{C}/\text{W}$
$R_{\theta JA}$	Junction-to-Ambient	62.5	$^\circ\text{C}/\text{W}$

### Thermal characteristics (FullPAK) TO-220F

Symbol	Parameter	RATINGS	Units
$R_{\theta JC}$	Junction-to-Case	2.8	$^\circ\text{C}/\text{W}$
$R_{\theta JA}$	Junction-to-Ambient	62.5	$^\circ\text{C}/\text{W}$

## 4. Electrical Characteristics

at  $T_c = 25^\circ\text{C}$ , unless otherwise specified

OFF Characteristics						
Symbol	Parameter	Test Conditions	Values			Units
			Min.	Typ.	Max.	
$V_{DSS}$	Drain to Source Breakdown Voltage	$V_{GS}=0V$ , $I_D=250\mu A$	650	--	--	V
$\Delta BV_{DSS}/\Delta T_J$	Bvdss Temperature Coefficient	$I_D=250\mu A$ , Reference $25^\circ\text{C}$	--	0.6	--	$V/^\circ\text{C}$
$I_{DSS}$	Drain to Source Leakage Current	$V_{DS}=650V$ , $V_{GS}=0V$ , $T_J=25^\circ\text{C}$	--	--	1	$\mu A$
		$V_{DS}=520V$ , $V_{GS}=0V$ , $T_J=125^\circ\text{C}$	--	--	100	$\mu A$
$I_{GSS(F)}$	Gate to Source Forward Leakage	$V_{GS}=+30V$	--	--	100	nA
$I_{GSS(R)}$	Gate to Source Reverse Leakage	$V_{GS}=-30V$	--	--	100	nA

ON Characteristics						
Symbol	Parameter	Test Conditions	Values			Units
			Min.	Typ.	Max.	
$R_{DS(ON)}$	Drain-to-Source On-Resistance	$V_{GS}=10V$ , $I_D=5A(\text{Note4})$	--	0.87	1	$\Omega$
$V_{GS(TH)}$	Gate Threshold Voltage	$V_{DS}=V_{GS}$ , $I_D=250\mu A(\text{Note4})$	2.0	3.0	4.0	V
$g_{fs}$	Forward Transconductance	$V_{DS}=15V$ , $I_D=10A(\text{Note4})$	--	8.6	--	S

Dynamic Characteristics						
Symbol	Parameter	Test Conditions	Values			Units
			Min.	Typ.	Max.	
$R_g$	Gate resistance	$f=1.0\text{MHz}$	--	3.6	--	$\Omega$
$C_{iss}$	Input Capacitance	$V_{GS}=0V$ $V_{DS}=25V$ $f=1.0\text{MHz}$	--	1670	--	PF
$C_{oss}$	Output Capacitance		--	120	--	
$C_{rss}$	Reverse Transfer Capacitance		--	2.6	--	

Switching Characteristics						
Symbol	Parameter	Test Conditions	Values			Units
			Min.	Typ.	Max.	
$t_{d(ON)}$	Turn-on Delay Time	ID =10A VDD = 325V VGS = 10V RG =5Ω	--	25	--	ns
$t_r$	Rise Time		--	70	--	
$t_{d(OFF)}$	Turn-Off Delay Time		--	145	--	
$t_f$	Fall Time		--	80	--	
$Q_g$	Total Gate Charge	ID =10A VDD =520V VGS = 10V	--	32	--	nC
$Q_{gs}$	Gate to Source Charge		--	10	--	
$Q_{gd}$	Gate to Drain ("Miller")Charge		--	8.5	--	

Source-Drain Diode Characteristics						
Symbol	Parameter	Test Conditions	Values			Units
			Min.	Typ.	Max.	
$I_S$	Continuous Source Current (Body Diode)	TC=25 °C	--	--	10	A
$I_{SM}$	Maximum Pulsed Current (Body Diode)		--	--	40	A
$V_{SD}$	Diode Forward Voltage	IS=10A, VGS=0V(Note4)	--	--	1.2	V
$T_{rr}$	Reverse Recovery Time	IS=10A, Tj = 25°C dIF/dt=100A/us, VGS=0V	--	420	--	ns
$Q_{rr}$	Reverse Recovery Charge		--	4200	--	nC

Note1: Pulse width limited by maximum junction temperature

Note2: L=10mH, VD<sub>s</sub>=150V, Start T<sub>J</sub>=25°C

Note3: ISD =10A, di/dt ≤100A/us, VDD≤BVDS, Start T<sub>J</sub>=25°C

Note4: Pulse width tp≤300μs, δ≤2%



## 5. Characteristics Curves

Figure 1a Safe Operating Area (No FullPAK)

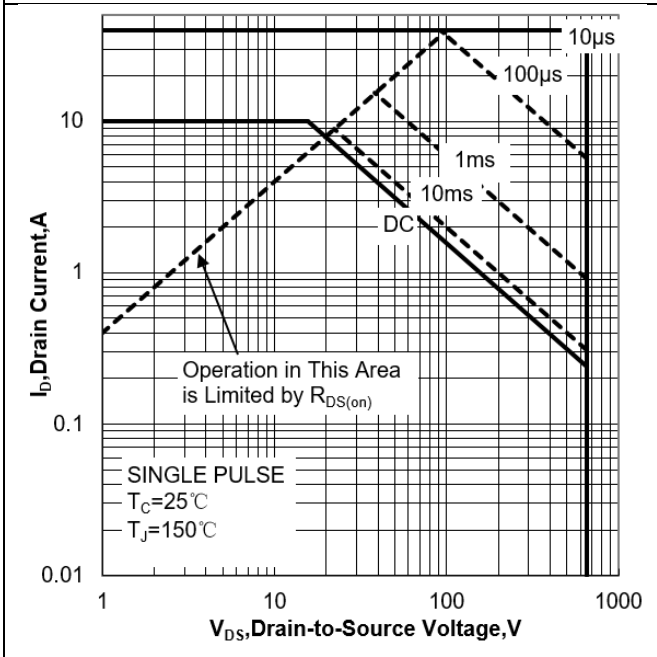


Figure 1b Safe Operating Area (FullPAK)

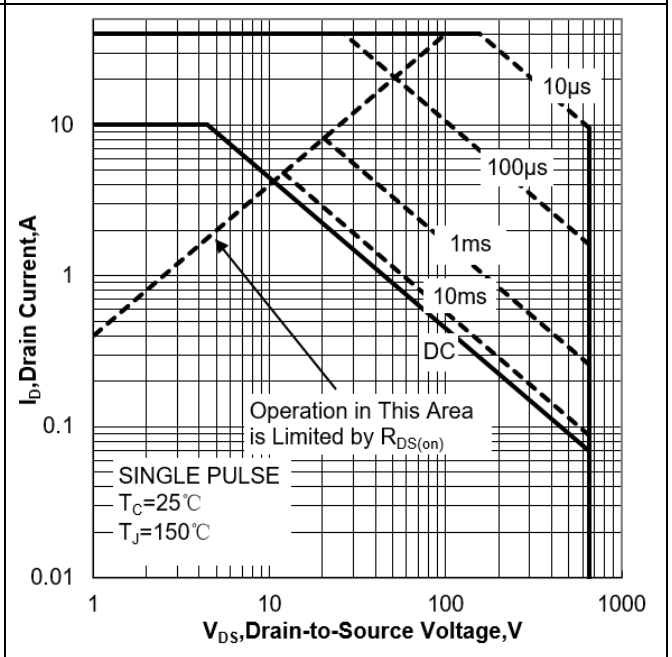


Figure 2a Power Dissipation (No FullPAK)

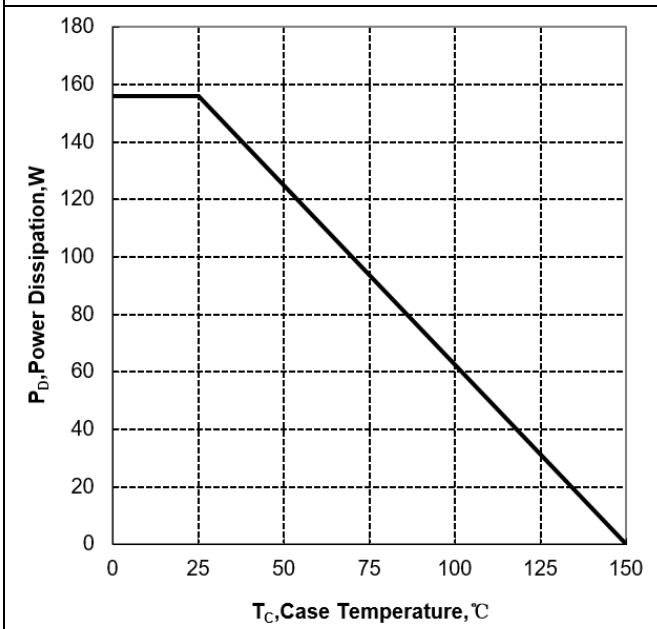


Figure 2b Power Dissipation (FullPAK)

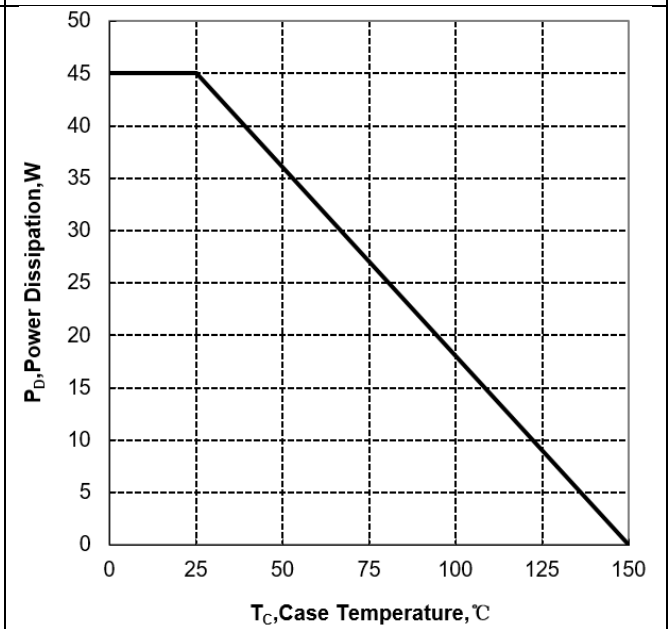




Figure 3a Max Thermal Impedance (No FullPAK)

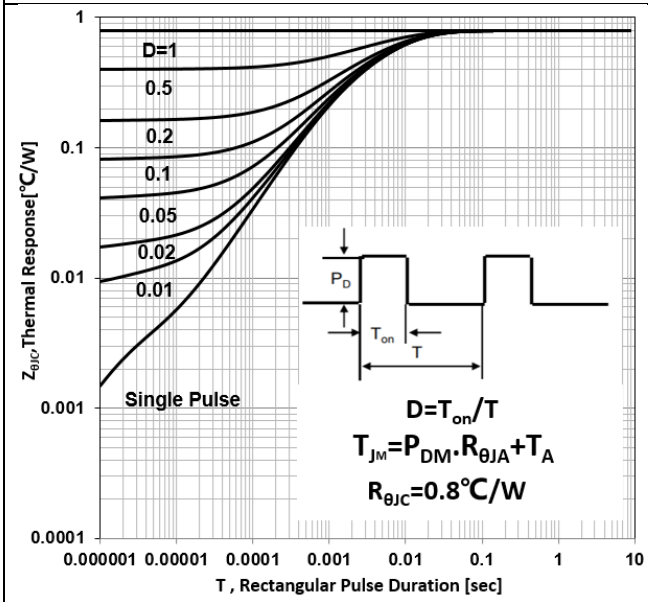


Figure 3b Max Thermal Impedance (FullPAK)

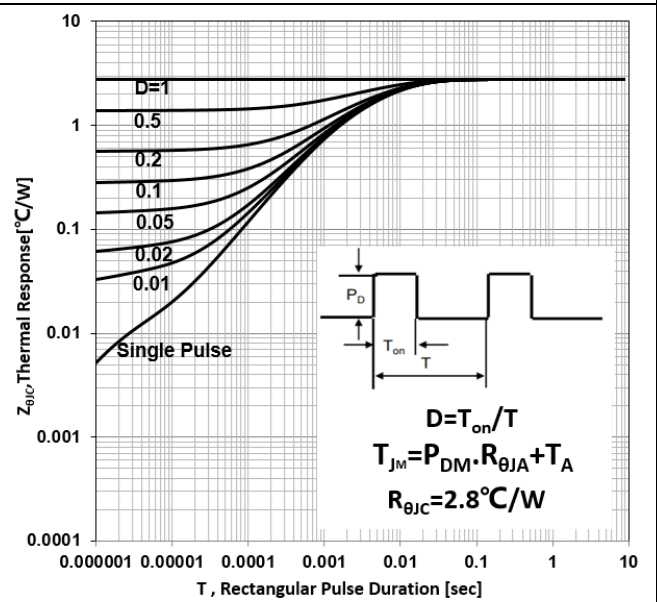


Figure 4 Typical Output Characteristics

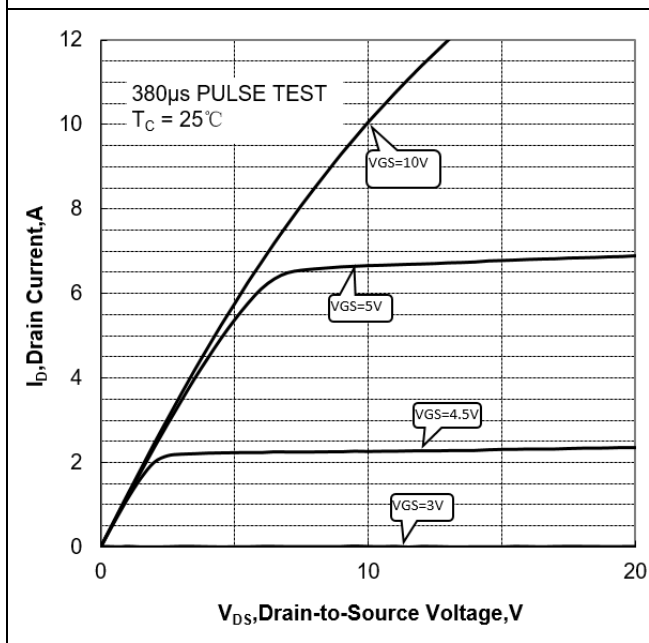
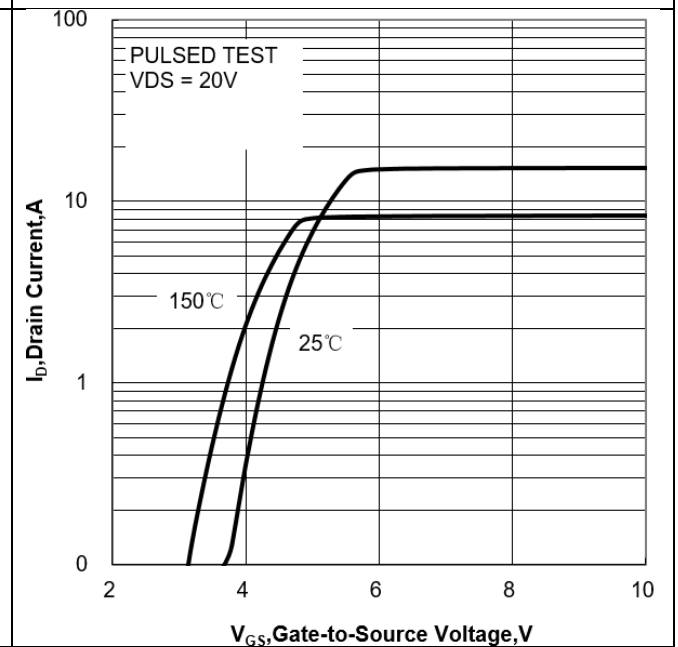
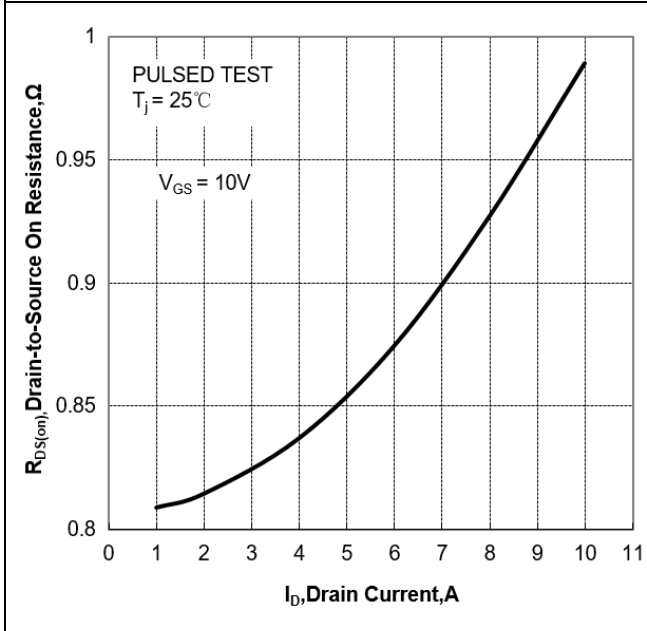


Figure 5 Typical Transfer Characteristics

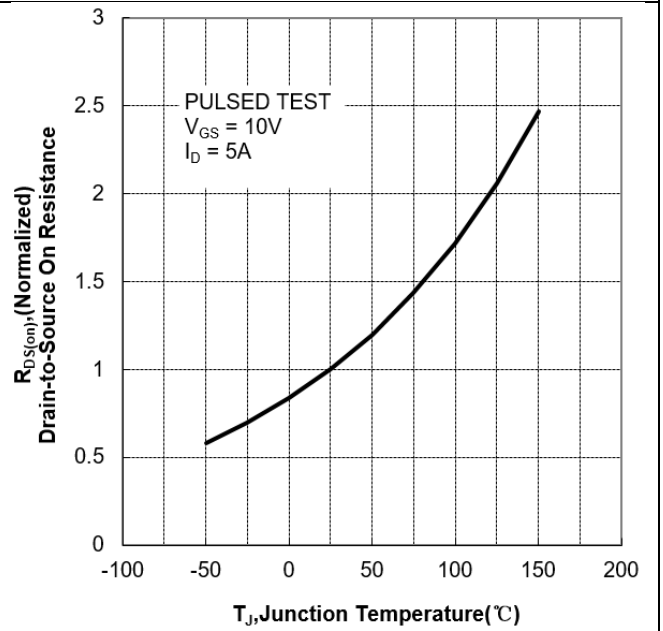




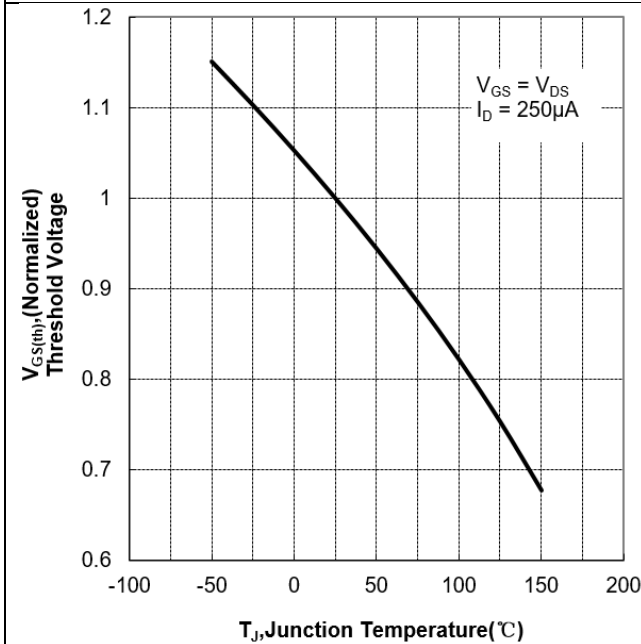
**Figure 6 Typical Drain to Source ON Resistance vs Drain Current**



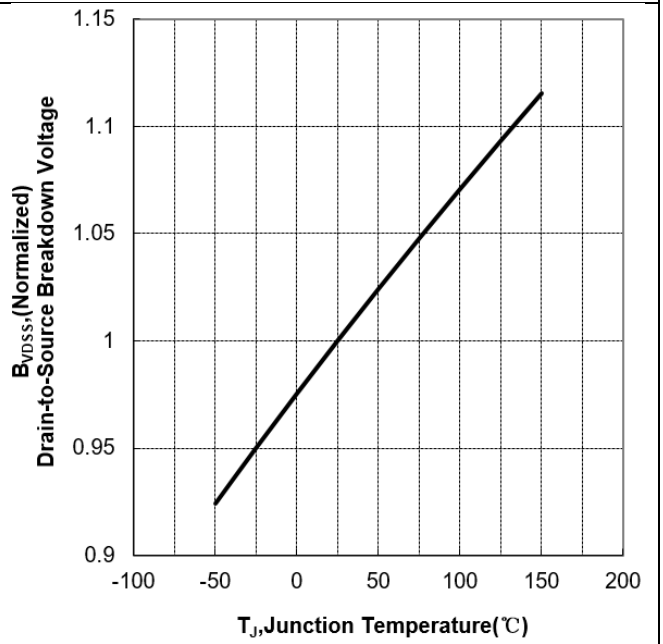
**Figure 7 Typical Drain to Source on Resistance vs Junction Temperature**



**Figure 8 Typical Theshold Voltage vs Junction Temperature**

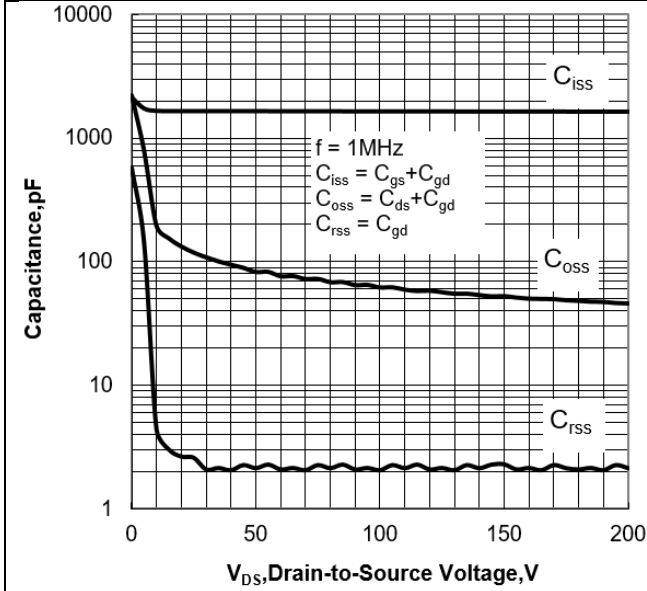


**Figure 9 Typical Breakdown Voltage vs Junction Temperature**

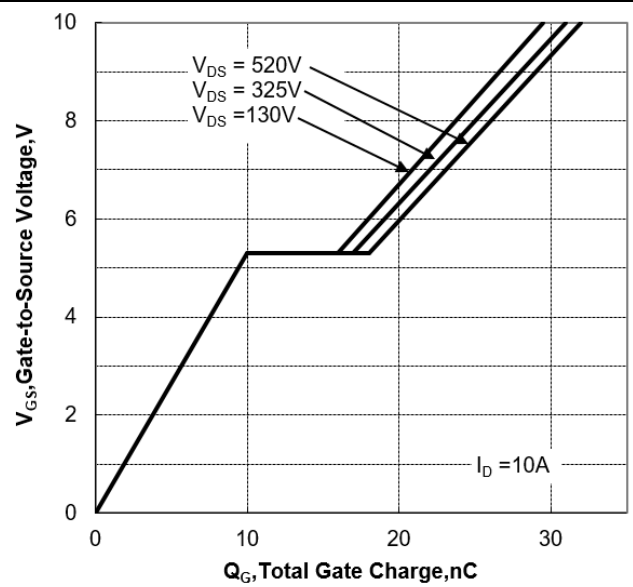




**Figure 10 Typical Theshold Voltage vs Junction Temperature**



**Figure 11 Typical Breakdown Voltage vs Junction Temperature**





## 6. Test Circuit and Waveform

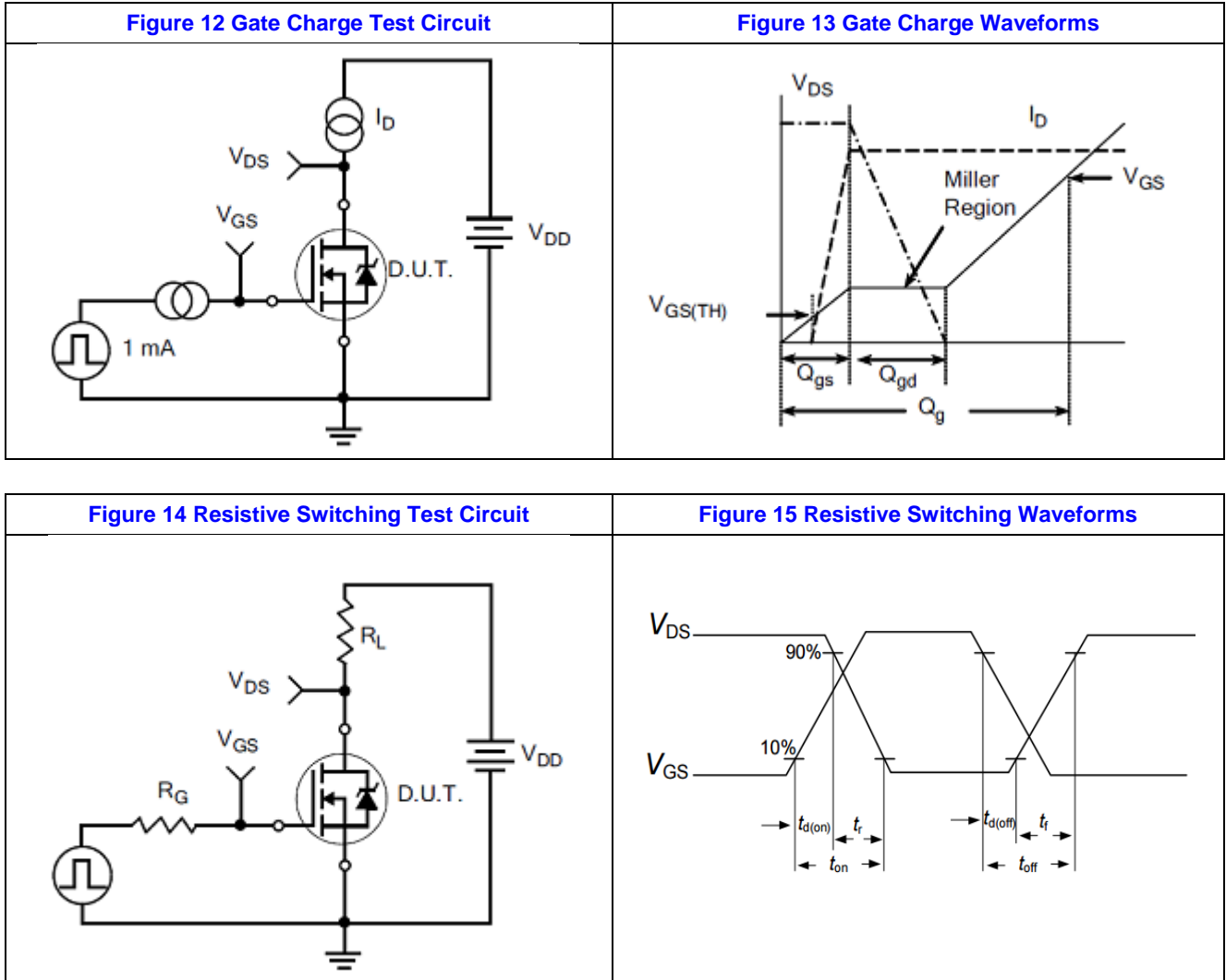




Figure 16 Diode Reverse Recovery Test Circuit

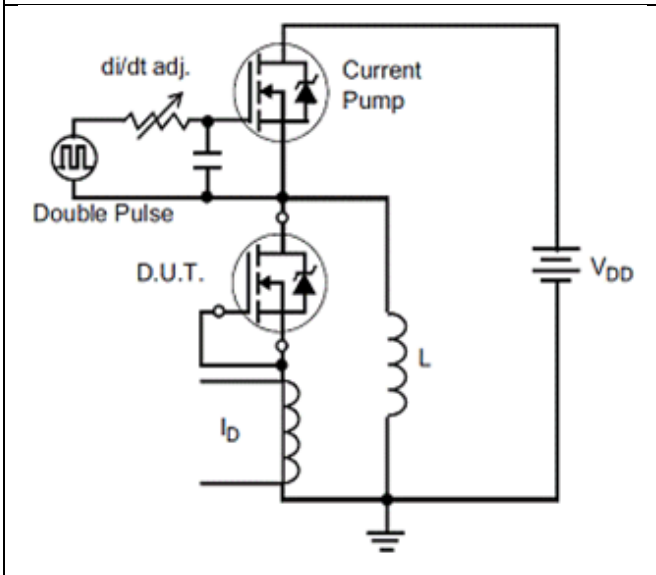


Figure 17 Diode Reverse Recovery Waveform

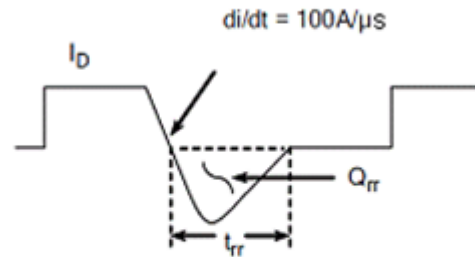


Figure 18 Unclamped Inductive Switching Test Circuit

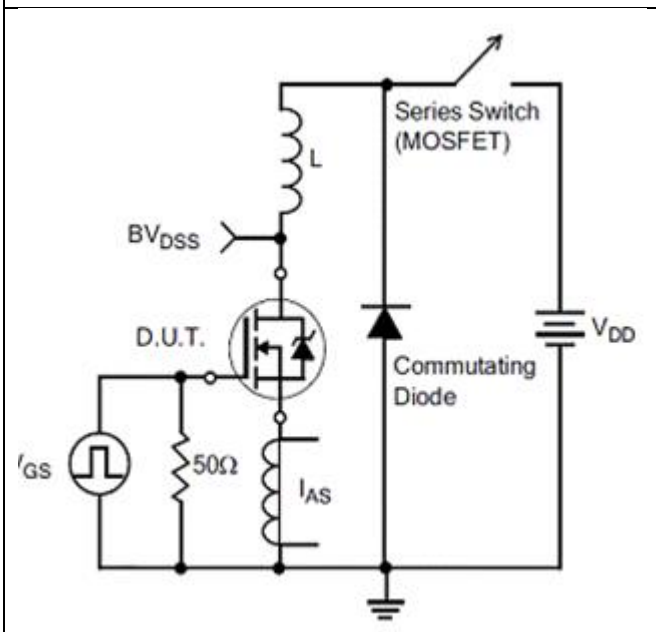
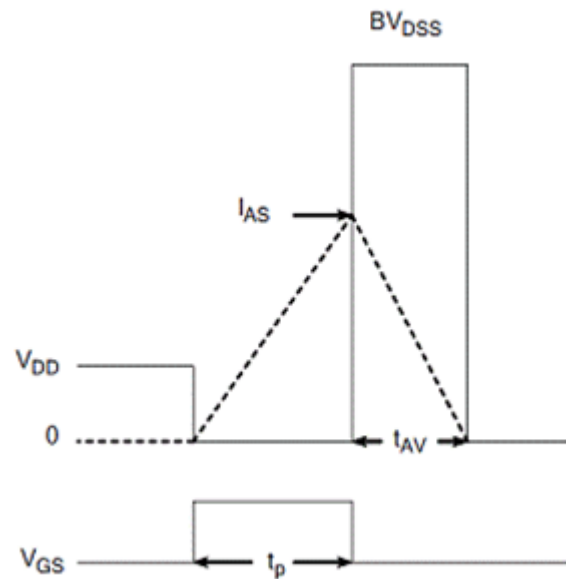
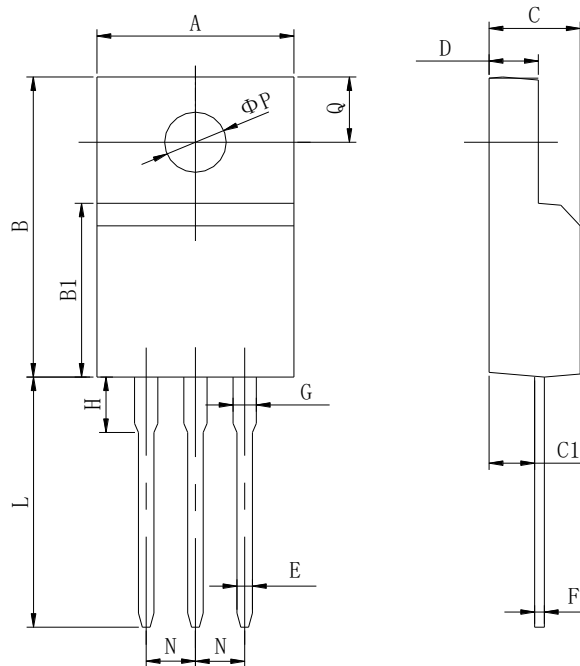


Figure 19 Unclamped Inductive Switching Waveform

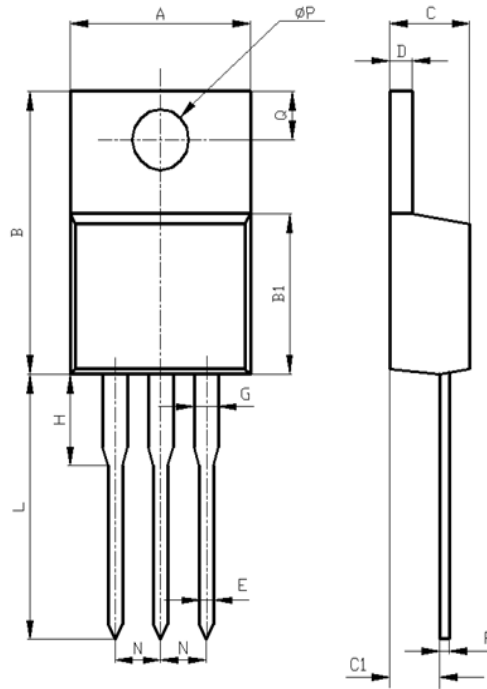


## 7. Package Description



Items	Values(mm)	
	MIN	MAX
A	9.60	10.4
B	15.4	16.2
B1	8.90	9.50
C	4.30	4.90
C1	2.10	3.00
D	2.40	3.00
E	0.60	1.00
F	0.30	0.60
G	1.12	1.42
H	3.40	3.80
	1.60	2.90
L	12.0	14.0
N	2.34	2.74
Q	3.15	3.55
$\phi P$	2.90	3.30

TO-220F Package



Items	Values(mm)	
	MIN	MAX
A	9.60	10.6
B	15.0	16.0
B1	8.90	9.50
C	4.30	4.80
C1	2.30	3.10
D	1.20	1.40
E	0.70	0.90
F	0.30	0.60
G	1.17	1.37
H	2.70	3.80
L	12.6	14.8
N	2.34	2.74
Q	2.40	3.00
Φ P	3.50	3.90

## TO-220 Package



**NOTE:**

1. Exceeding the maximum ratings of the device in performance may cause damage to the device, even the permanent failure, which may affect the dependability of the machine. Please do not exceed the absolute maximum ratings of the device when circuit designing.
2. When installing the heat sink, please pay attention to the torsional moment and the smoothness of the heat sink.
3. MOSFETs is the device which is sensitive to the static electricity, it is necessary to protect the device from being damaged by the static electricity when using it.
4. Shanghai Jerrett reserves the right to make changes in this specification sheet and is subject to change without prior notice.