

## 1. Description

JRP03N08, the N-channel Enhanced Power MOSFETs, is obtained by advanced double trench technology which reduce the conduction loss, improve switching performance and enhance the avalanche energy. This is suitable device for BMS and high current switching applications.

### KEY CHARACTERISTICS

| Parameter               | Value | Unit |
|-------------------------|-------|------|
| V <sub>DSS</sub>        | 85    | V    |
| I <sub>D</sub>          | 180   | A    |
| R <sub>DS(on).typ</sub> | 2.3   | mΩ   |

### FEATURES

- Fast Switching
- Low On-Resistance (  $R_{DS(on)} \leq 3m\Omega$  )
- Low Gate Charge
- Low Reverse transfer capacitances
- High avalanche ruggedness
- RoHS product

### APPLICATIONS

- BMS
- High current switching applications

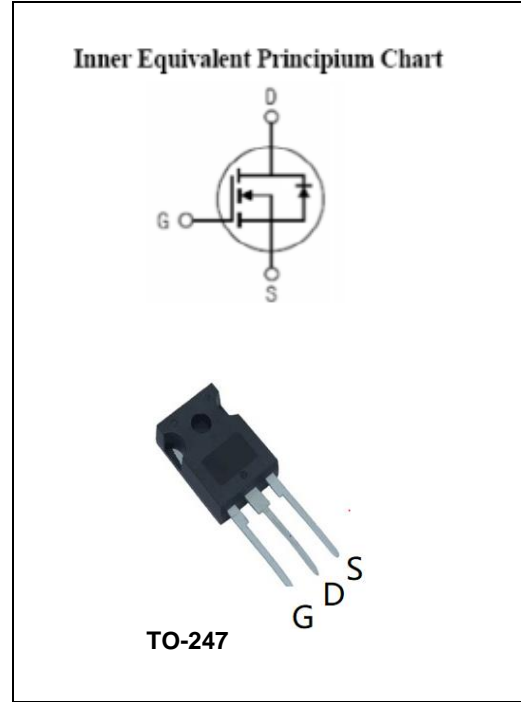

### ORDERING INFORMATION

| Ordering Codes | Package | Product Code | Packing |
|----------------|---------|--------------|---------|
| JRP03N08-F     | TO-247  | P03N08       | Tube    |

|   |   |
|---|---|
| <p>JRP03N08-F</p> <div style="border: 1px solid black; padding: 5px; width: fit-content; margin-left: 20px;"> <p>(2) Package type</p> <p>(1) Chip name</p> </div> <p>(1) JRP03N08: 3mΩ/85V</p> <p>(2) F: TO-247</p> | <div style="border: 1px solid black; padding: 5px; width: fit-content; margin-left: 20px;"> <p> XXXXX<br/>YYWW ZZ<br/>SSSSS</p> </div> <p>XXXXX: Product Code</p> <p>YYWW: Year&amp;Week</p> <p>ZZ: Assembly Code</p> <p>SSSSS: Lot Code</p> |
|---|---|

## 2. ABSOLUTE RATINGS

at  $T_C=25^{\circ}\text{C}$ , unless otherwise specified

| Symbol                    | Parameter  | Rating              | Units                 |
|---------------------------|--|---------------------|-----------------------|
| $V_{DSS}$                 | Drain-Source Voltage   | 85                  | V                     |
| $I_D$                     | Continuous Drain Current, Silicon Limited                              | 275                 | A                     |
|                           | Continuous Drain Current, Package Limited                              | 180                 | A                     |
|                           | Continuous Drain Current @ $T_C=100^{\circ}\text{C}$ , Silicon Limited | 173.9               | A                     |
| $I_{DM}$ <sup>Note1</sup> | Pulsed Drain Current   | 720                 | A                     |
| $V_{GS}$                  | Gate-Source Voltage  | $\pm 20$            | V                     |
| $E_{AS}$ <sup>Note2</sup> | Avalanche Energy   | 900                 | mJ                    |
| $P_D$                     | Power Dissipation  | 357                 | W                     |
|                           | Derating Factor above $25^{\circ}\text{C}$                             | 2.85                | W/ $^{\circ}\text{C}$ |
| $T_J, T_{stg}$            | Operating Junction and Storage Temperature Range                       | 150, $-55$ to $150$ | $^{\circ}\text{C}$    |
| $T_L$                     | Maximum Temperature for Soldering                                      | 260                 | $^{\circ}\text{C}$    |

Note1: Repetitive Rating: Pulse width limited by maximum junction temperature

Note2:  $L=0.5\text{mH}$ ,  $I_{as}=60\text{A}$ , Start  $T_J=25^{\circ}\text{C}$

## 3. Thermal characteristics

| Symbol          | Parameter                            | Max  | Units                       |
|-----------------|--------------------------------------|------|-----------------------------|
| $R_{\theta JC}$ | thermal resistance, Junction-Case    | 0.35 | $^{\circ}\text{C}/\text{W}$ |
| $R_{\theta JA}$ | thermal resistance, Junction-Ambient | 62.5 | $^{\circ}\text{C}/\text{W}$ |

## 4. Electrical Characteristics

at  $T_C=25^{\circ}\text{C}$ , unless otherwise specified

| OFF Characteristics |                                |   |        |     |      |               |
|---------------------|--------------------------------|---|--------|-----|------|---------------|
| Symbol              | Parameter                      | Test Conditions   | Values |     |      | Units         |
|                     |                                |   | Min    | Typ | Max  |               |
| $V_{DSS}$           | Drain-Source Breakdown Voltage | $V_{GS}=0\text{V}$ , $I_D=250\mu\text{A}$                               | 85     | 95  | --   | V             |
| $I_{DSS}$           | Drain-Source Leakage Current   | $V_{DS}=85\text{V}$ , $V_{GS}=0\text{V}$                                | --     | --  | 1    | $\mu\text{A}$ |
|                     |                                | $V_{DS}=68\text{V}$ , $V_{GS}=0\text{V}$<br>@ $T_C=125^{\circ}\text{C}$ | --     | --  | 100  | $\mu\text{A}$ |
| $I_{GSS(F)}$        | Gate-Source Forward Leakage    | $V_{GS}=+20\text{V}$  | --     | --  | 100  | nA            |
| $I_{GSS(R)}$        | Gate-Source Reverse Leakage    | $V_{GS}=-20\text{V}$  | --     | --  | -100 | nA            |

### ON Characteristics

| Symbol   | Parameter                  | Test Conditions               | Values |     |     | Unit<br>S  |
|--|----------------------------|-------------------------------|--------|-----|-----|------------|
|  |                            |                               | Min    | Typ | Max |            |
| $R_{DS(on)}$                                     | Drain-Source On-Resistance | $V_{GS}=10V, I_D=50A$         | --     | 2.3 | 3   | m $\Omega$ |
| $V_{GS(th)}$                                     | Gate Threshold Voltage     | $V_{DS}=V_{GS}, I_D=250\mu A$ | 2      | 3   | 4   | V          |
| Pulse width $t_p \leq 300\mu s, \delta \leq 2\%$ |                            |                               |        |     |     |            |

### Dynamic Characteristics

| Symbol    | Parameter                    | Test Conditions                               | Values |       |     | Units |
|-----------|------------------------------|---|--------|-------|-----|-------|
|           |                              |   | Min    | Typ   | Max |       |
| $C_{iss}$ | Input Capacitance            | $V_{DS}=42.5V,$<br>$V_{GS}=0,$<br>$f=1MHz$    | --     | 8237  | --  | pF    |
| $C_{oss}$ | Output Capacitance           |   | --     | 1549  | --  |       |
| $C_{rss}$ | Reverse Transfer Capacitance |   | --     | 152   | --  |       |
| $Q_g$     | Total Gate Charge            | $V_{DD}=42.5V,$<br>$I_D=50A,$<br>$V_{GS}=10V$ | --     | 138.3 | --  | nC    |
| $Q_{gs}$  | Gate-Source charge           |   | --     | 39.5  | --  |       |
| $Q_{gd}$  | Gate-Drain charge            |   | --     | 36.8  | --  |       |

### Switching Characteristics

| Symbol       | Parameter           | Test Conditions  | Values |     |     | Units |
|--------------|---------------------|--|--------|-----|-----|-------|
|              |                     |  | Min    | Typ | Max |       |
| $t_{d(on)}$  | Turn-On Delay Time  | $V_{DD}=42.5V,$<br>$V_{GS}=10V,$<br>$R_G=3\Omega,$<br>Resistive Load | --     | 32  | --  | ns    |
| $t_r$        | Rise Time           |  | --     | 115 | --  |       |
| $t_{d(off)}$ | Turn-Off Delay Time |  | --     | 93  | --  |       |
| $t_f$        | Fall Time           |  | --     | 140 | --  |       |

### Source-Drain Diode Characteristics

| Symbol   | Parameter                 | Test Conditions                            | Values |     |     | Units |
|----------|---------------------------|--|--------|-----|-----|-------|
|          |                           |  | Min    | Typ | Max |       |
| $I_S$    | Continuous Source Current |  | --     | --  | 180 | A     |
| $I_{SM}$ | Maximum Pulsed Current    |  | --     | --  | 720 | A     |
| $V_{SD}$ | Diode Forward Voltage     | $V_{GS}=0V, I_S=50A$                       | --     | --  | 1.2 | V     |
| $T_{rr}$ | Reverse Recovery Time     | $I_S=50A, V_{GS}=0,$<br>$di/dt=100A/\mu s$ | --     | 80  | --  | ns    |
| $Q_{rr}$ | Reverse Recovery Charge   |  | --     | 196 | --  | nC    |



## 5. Characteristics Curves

Figure 1. Safe Operating Area

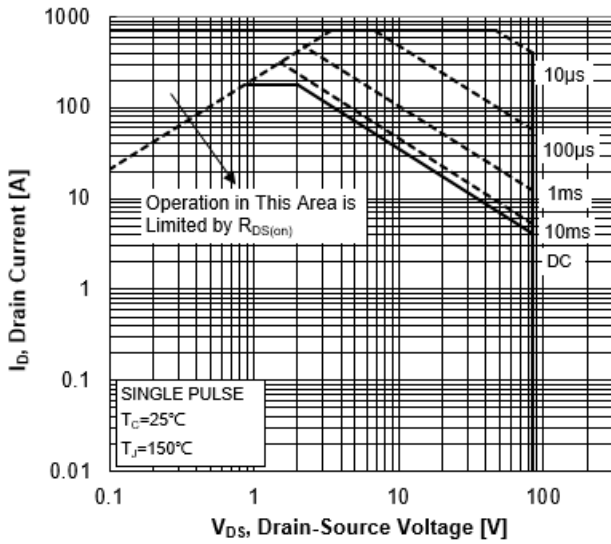

Figure 2. Maximum Power Dissipation vs Case Temperature

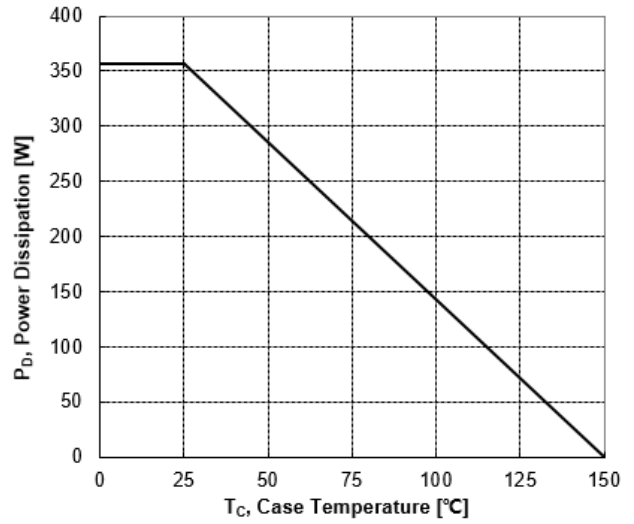

Figure 3. Maximum Continuous Drain Current vs Case Temperature

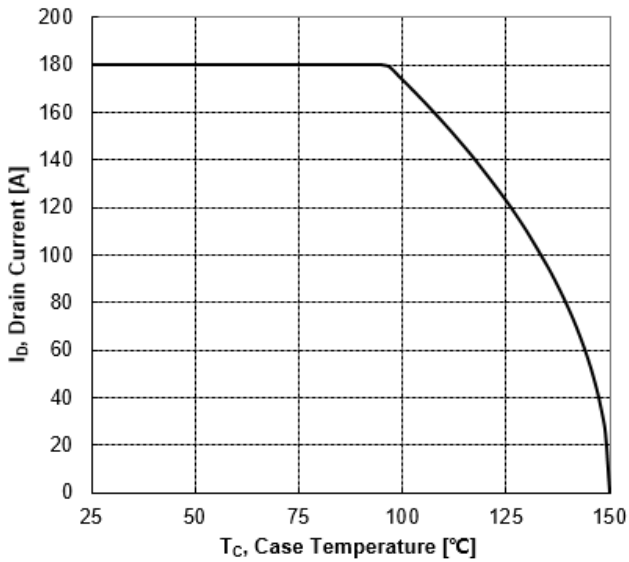

Figure 4. Typical Output Characteristics

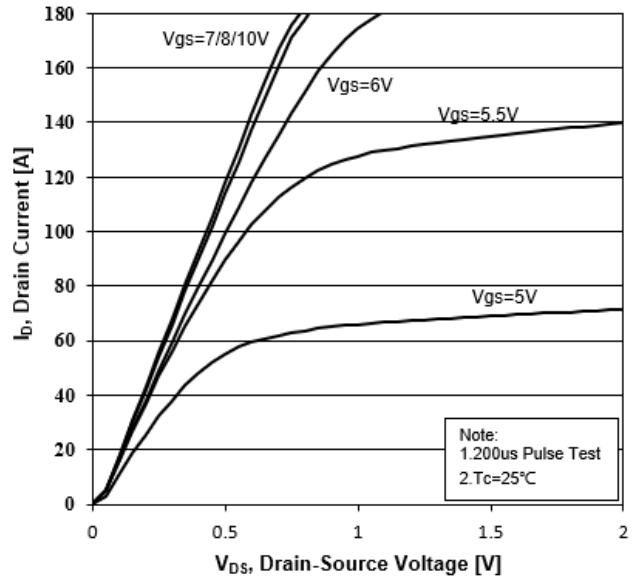



Figure 5. Transient Thermal Impedance

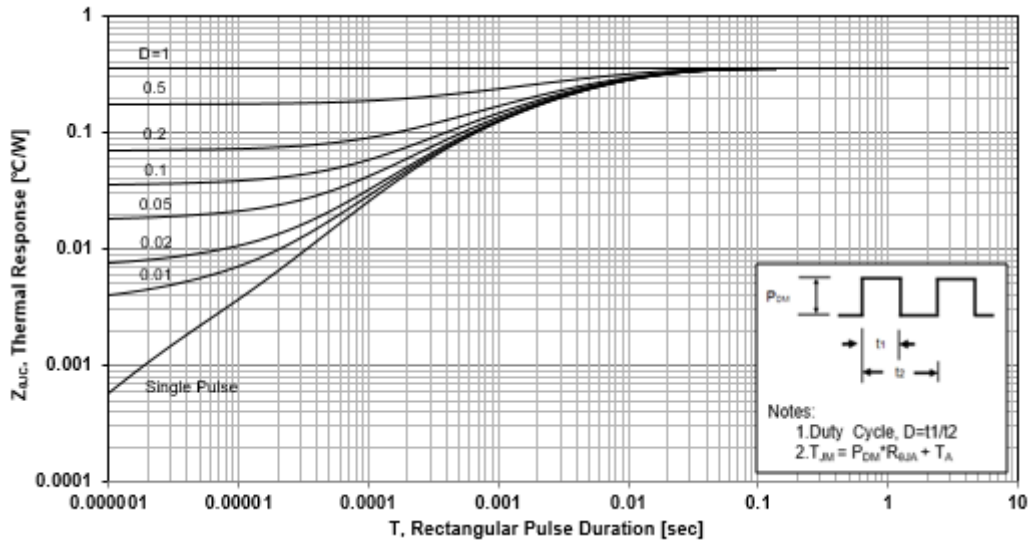

Figure 6. Typical Transfer Characteristics

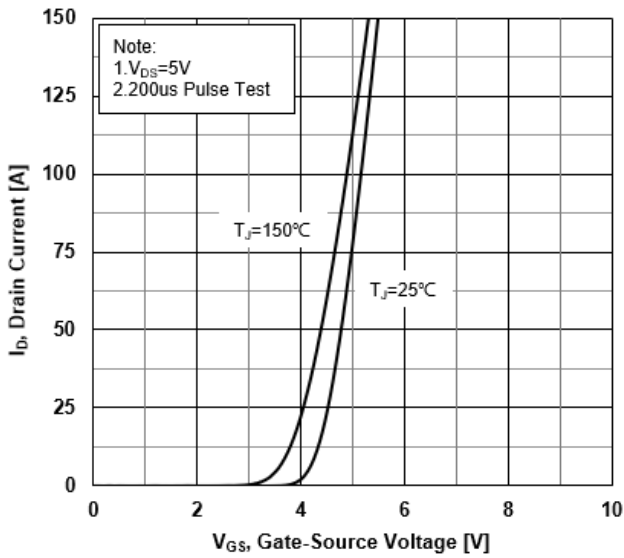
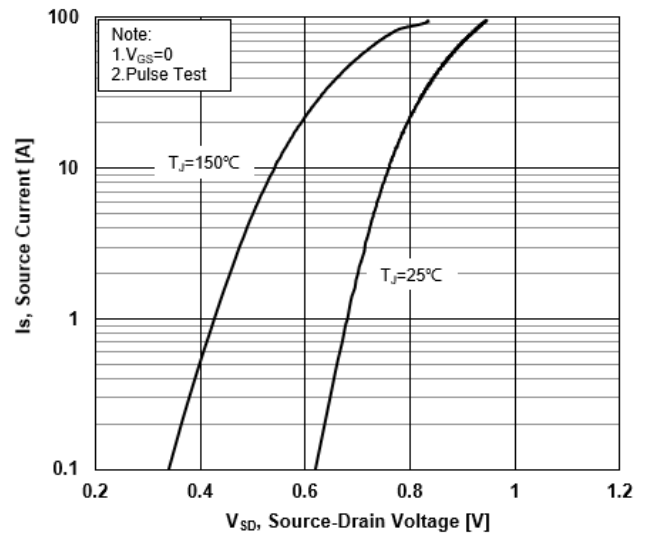
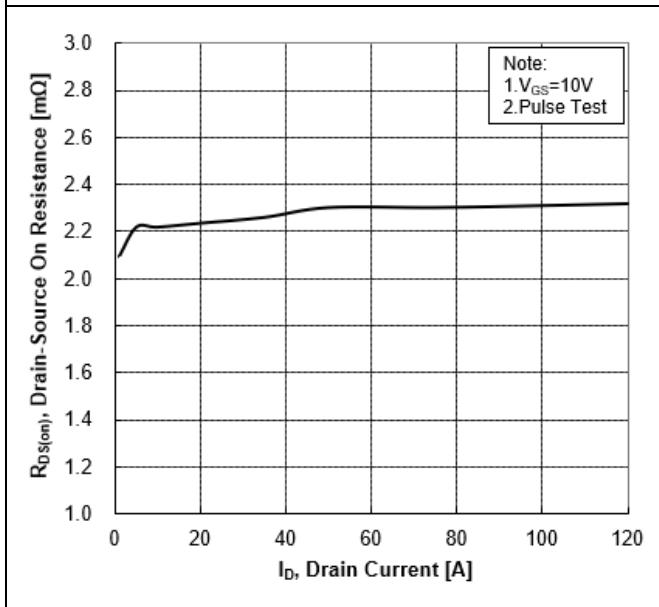

Figure 7. Source-Drain Diode Forward Characteristics

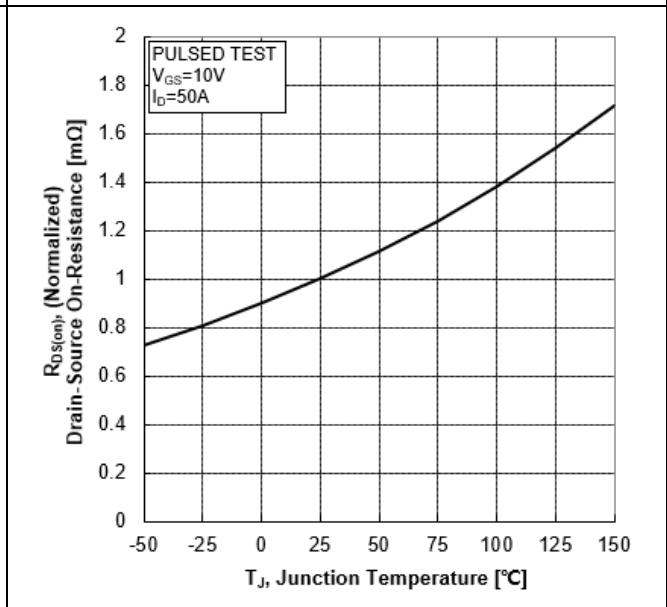



**Figure 8. Drain-Source On-Resistance vs Drain Current**



**Figure 9. Normalized On-Resistance vs Junction Temperature**



**Figure 10. Normalized Threshold Voltage vs Junction Temperature**

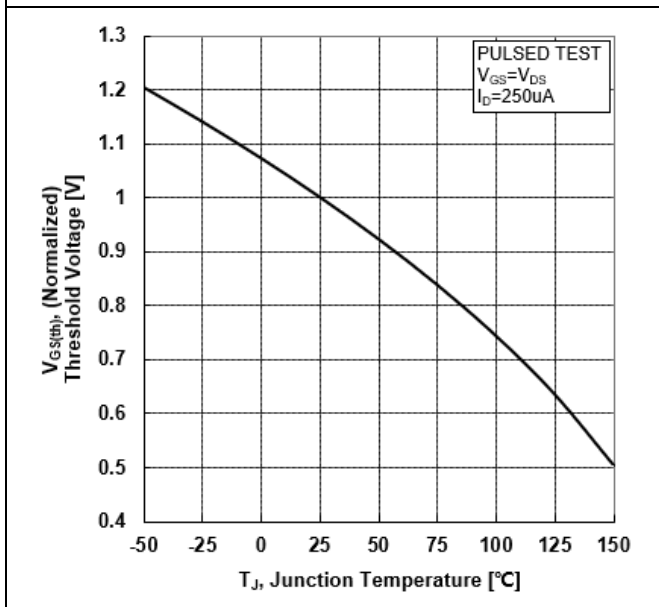

**Figure 11. Normalized Breakdown Voltage vs Junction Temperature**

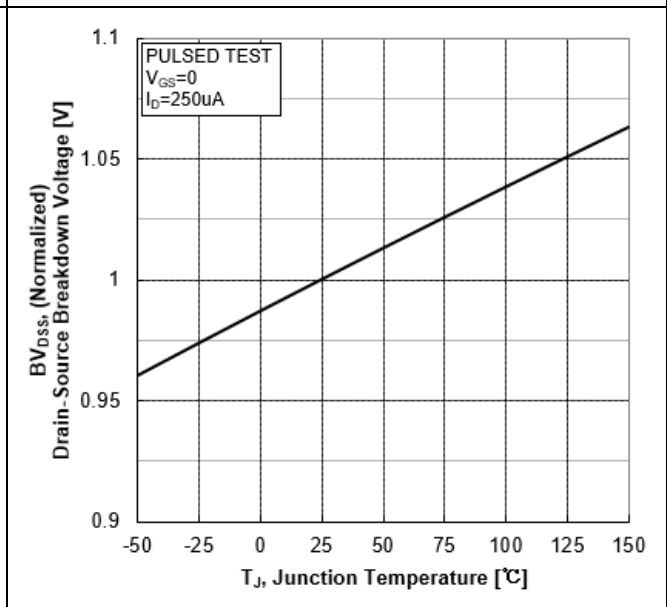



Figure 12. Capacitance Characteristics

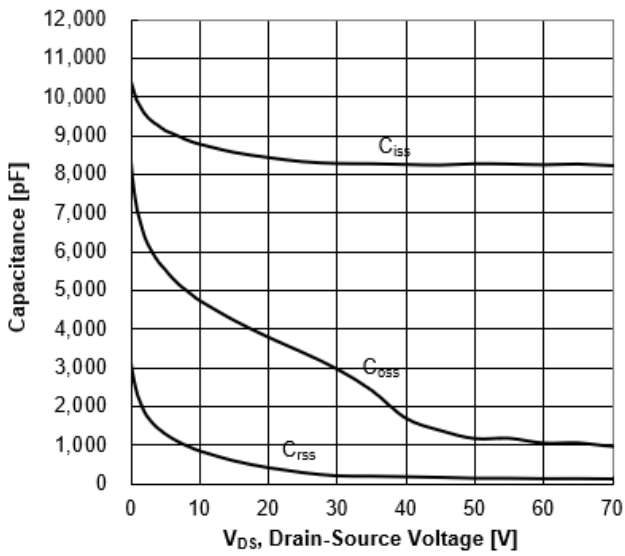
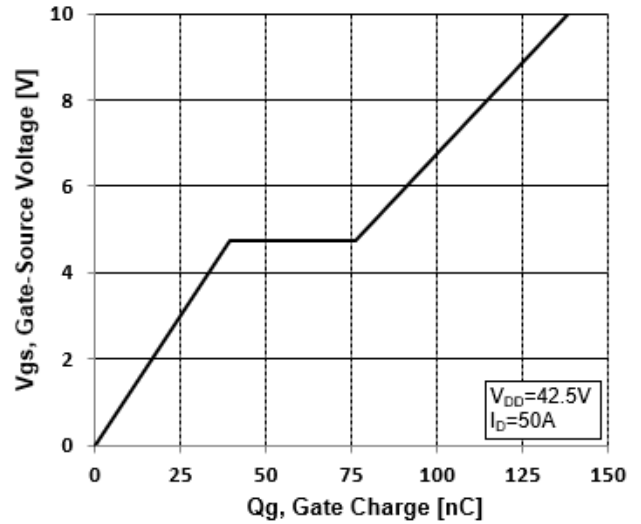

Figure 13. Typical Gate Charge vs Gate-Source Voltage



## 6. Test Circuit and Waveform

Figure 14. Resistive Switching Test Circuit

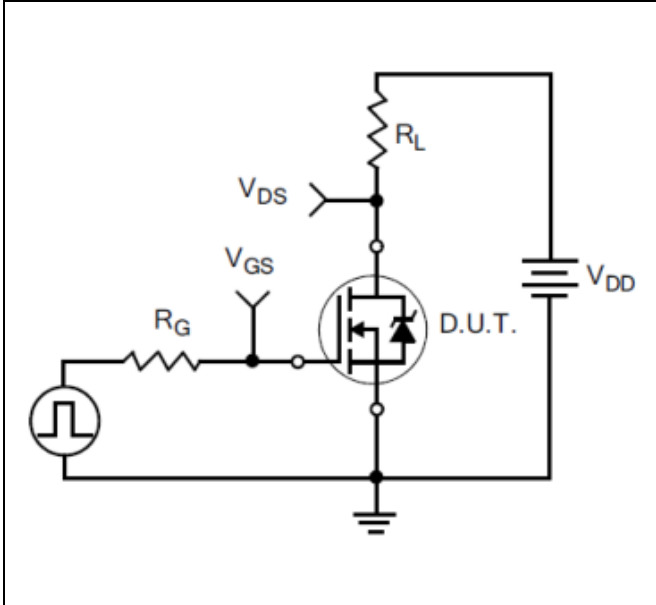

Figure 15. Resistive Switching Waveforms



Figure 16. Gate Charge Test Circuit

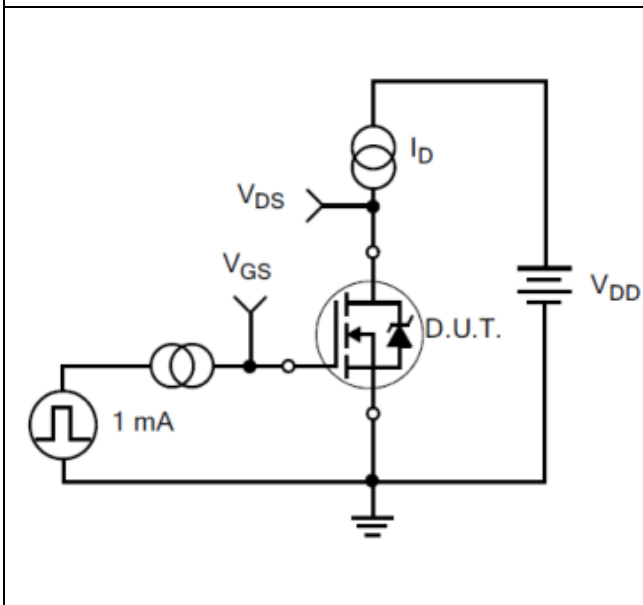

Figure 17. Gate Charge Waveforms

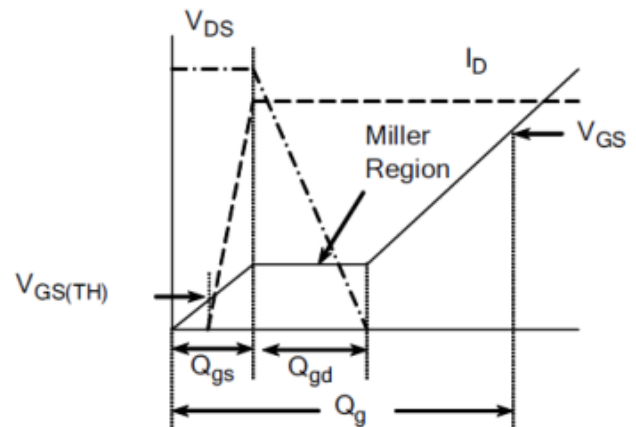



Figure 18. Diode Reverse Recovery Test Circuit

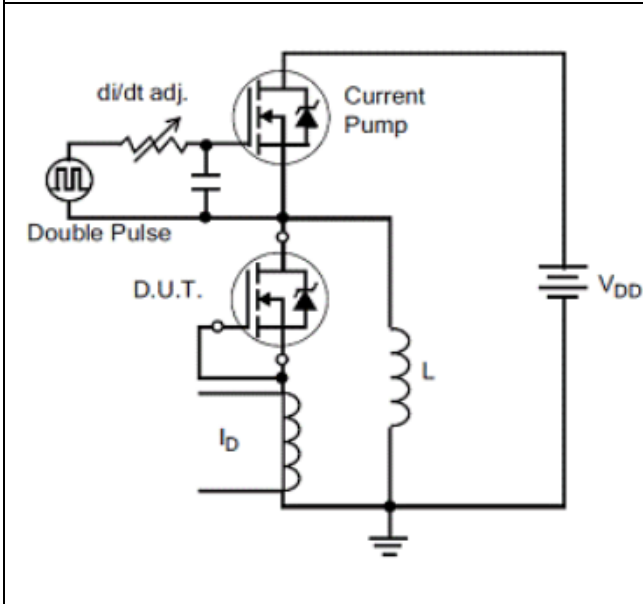

Figure 19. Diode Reverse Recovery Waveform

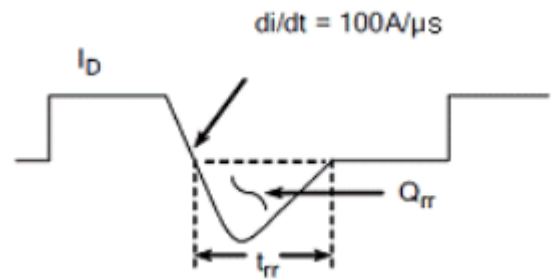

Figure 20. Unclamped Inductive Switching Test Circuit

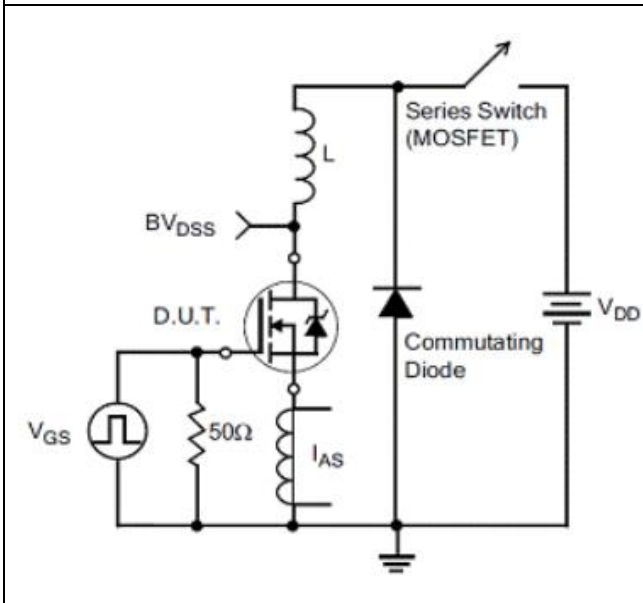
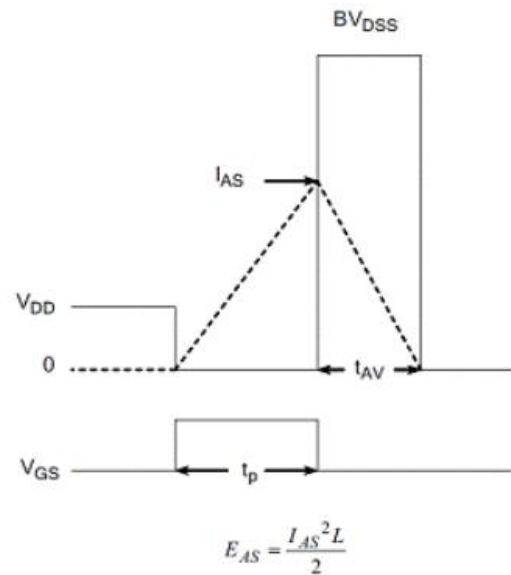
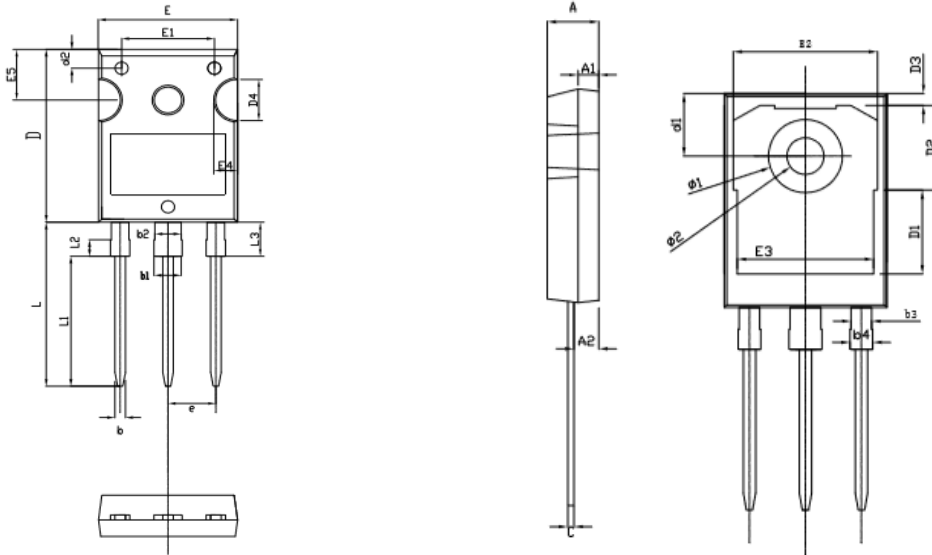

Figure 21. Unclamped Inductive Switching Waveform



## 7. Package Description

TO-247



RECOMMENDED LAND PATTERN

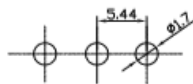

UNIT: mm

|      | MIN   | NOM   | MAX   |
|------|-------|-------|-------|
| A    | 4.85  | 5.00  | 5.15  |
| A1   | 1.90  | 2.00  | 2.10  |
| A2   | 2.27  | 2.41  | 2.54  |
| b    | 1.10  | 1.20  | 1.30  |
| b1   | 2.90  | -     | 3.20  |
| b2   | 2.90  | 3.00  | 3.10  |
| b3   | 1.90  | 2.00  | 2.10  |
| b4   | 2.00  | -     | 2.20  |
| c    | 0.55  | 0.60  | 0.68  |
| D    | 20.80 | 21.00 | 21.10 |
| D1   |       | 8.23  |       |
| D2   |       | 8.32  |       |
| D3   |       | 1.17  |       |
| D4   | 3.68  | 4.90  | 5.10  |
| d1   | 6.04  | 6.15  | 6.30  |
| d2   | 2.20  | 2.30  | 2.40  |
| E    | 15.70 | 15.80 | 16.00 |
| E1   |       | 10.50 |       |
| E2   |       | 14.02 |       |
| E3   |       | 13.50 |       |
| E4   | 2.20  | 2.40  | 2.60  |
| E5   | 5.49  | 5.80  | 6.00  |
| e    | 5.34  | 5.44  | 5.54  |
| L    | 19.72 | 19.92 | 20.12 |
| L1   |       | 15.79 |       |
| L2   |       | 1.98  |       |
| L3   | 4.00  | 4.10  | 4.47  |
| phi1 | 7.10  | 7.19  | 7.30  |
| phi2 | 3.50  | 3.60  | 3.70  |



**NOTE:**

1. Exceeding the maximum ratings of the device in performance may cause damage to the device, even the permanent failure, which may affect the dependability of the machine. Please do not exceed the absolute maximum ratings of the device when circuit designing.
2. When installing the heat sink, please pay attention to the torsional moment and the smoothness of the heat sink.
3. MOSFETs is the device which is sensitive to the static electricity, it is necessary to protect the device from being damaged by the static electricity when using it.
4. Shanghai Jerrett reserves the right to make changes in this specification sheet and is subject to change without prior notice.