

## 1. Description

JRP04N08, the N-channel Enhanced Power MOSFETs, is obtained by advanced double trench technology which reduce the conduction loss, improve switching performance and enhance the avalanche energy. This is suitable device for BMS and high current switching applications.

### KEY CHARACTERISTICS

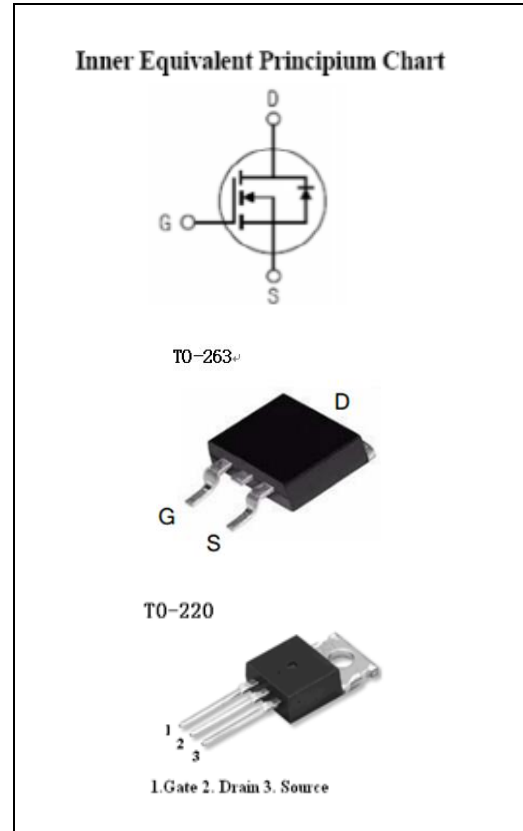
| Parameter               | Value | Unit |
|-------------------------|-------|------|
| V <sub>DSS</sub>        | 85    | V    |
| I <sub>D</sub>          | 120   | A    |
| R <sub>DS(on).typ</sub> | 3     | mΩ   |

### FEATURES

- Fast Switching
- Low On-Resistance (  $R_{DS(on)} \leq 3.6m\Omega$  )
- Low Gate Charge
- Low Reverse transfer capacitances
- High avalanche ruggedness
- RoHS product

### APPLICATIONS

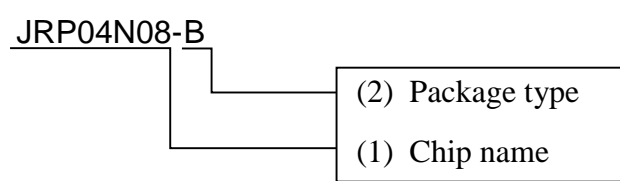
- BMS
- Motor drivers



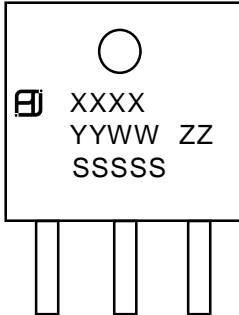
## ORDERING INFORMATION

| Ordering Codes | Package | Product Code | Packing |
|----------------|---------|--------------|---------|
| JRP04N08-B     | TO-263  | P04N08       | Reel    |
| JRP04N08-P     | TO-220  | P04N08       | Tube    |

**JRP04N08-B**



(1) JRP04N08: 4mΩ/85V  
(2) B: TO-263  
P: TO-220



XXXX: Product Code  
YYWW: Year&Week  
ZZ: Assembly Code  
SSSSS: Lot Code

## 2. ABSOLUTE RATINGS

at  $T_C=25^{\circ}\text{C}$ , unless otherwise specified

| Symbol                    | Parameter  | Rating              | Units                 |
|---------------------------|--|---------------------|-----------------------|
| $V_{DSS}$                 | Drain-Source Voltage   | 85                  | V                     |
| $I_D$                     | Continuous Drain Current, Silicon Limited                              | 185                 | A                     |
|                           | Continuous Drain Current, Package Limited                              | 120                 | A                     |
|                           | Continuous Drain Current @ $T_C=100^{\circ}\text{C}$ , Silicon Limited | 117.2               | A                     |
| $I_{DM}$ <sup>Note1</sup> | Pulsed Drain Current   | 480                 | A                     |
| $V_{GS}$                  | Gate-Source Voltage  | $\pm 20$            | V                     |
| $E_{AS}$ <sup>Note2</sup> | Avalanche Energy   | 625                 | mJ                    |
| $P_D$                     | Power Dissipation  | 208.3               | W                     |
|                           | Derating Factor above $25^{\circ}\text{C}$                             | 1.67                | W/ $^{\circ}\text{C}$ |
| $T_J, T_{stg}$            | Operating Junction and Storage Temperature Range                       | 150, $-55$ to $150$ | $^{\circ}\text{C}$    |
| $T_L$                     | Maximum Temperature for Soldering                                      | 260                 | $^{\circ}\text{C}$    |

Note1: Repetitive Rating: Pulse width limited by maximum junction temperature

Note2:  $L=0.5\text{mH}$ ,  $I_{as}=50\text{A}$ , Start  $T_J=25^{\circ}\text{C}$

## 3. Thermal characteristics

| Symbol          | Parameter                            | Max  | Units                       |
|-----------------|--------------------------------------|------|-----------------------------|
| $R_{\theta JC}$ | thermal resistance, Junction-Case    | 0.6  | $^{\circ}\text{C}/\text{W}$ |
| $R_{\theta JA}$ | thermal resistance, Junction-Ambient | 62.5 | $^{\circ}\text{C}/\text{W}$ |

## 4. Electrical Characteristics

at  $T_C=25^{\circ}\text{C}$ , unless otherwise specified

| OFF Characteristics |                                |   |        |     |      |               |
|---------------------|--------------------------------|---|--------|-----|------|---------------|
| Symbol              | Parameter                      | Test Conditions   | Values |     |      | Units         |
|                     |                                |   | Min    | Typ | Max  |               |
| $V_{DSS}$           | Drain-Source Breakdown Voltage | $V_{GS}=0\text{V}$ , $I_D=250\mu\text{A}$                               | 85     | 95  | --   | V             |
| $I_{DSS}$           | Drain-Source Leakage Current   | $V_{DS}=85\text{V}$ , $V_{GS}=0\text{V}$                                | --     | --  | 1    | $\mu\text{A}$ |
|                     |                                | $V_{DS}=68\text{V}$ , $V_{GS}=0\text{V}$<br>@ $T_C=125^{\circ}\text{C}$ | --     | --  | 100  | $\mu\text{A}$ |
| $I_{GSS(F)}$        | Gate-Source Forward Leakage    | $V_{GS}=+20\text{V}$  | --     | --  | 100  | nA            |
| $I_{GSS(R)}$        | Gate-Source Reverse Leakage    | $V_{GS}=-20\text{V}$  | --     | --  | -100 | nA            |

| ON Characteristics                               |                            |                               |        |     |     |            |
|--|----------------------------|-------------------------------|--------|-----|-----|------------|
| Symbol   | Parameter                  | Test Conditions               | Values |     |     | Unit<br>S  |
|  |                            |                               | Min    | Typ | Max |            |
| $R_{DS(on)}$                                     | Drain-Source On-Resistance | $V_{GS}=10V, I_D=50A$         | --     | 3   | 3.6 | m $\Omega$ |
| $V_{GS(th)}$                                     | Gate Threshold Voltage     | $V_{DS}=V_{GS}, I_D=250\mu A$ | 2      | 3   | 4   | V          |
| Pulse width $t_p \leq 300\mu s, \delta \leq 2\%$ |                            |                               |        |     |     |            |

| Dynamic Characteristics |                              |                                     |        |      |     |          |
|-------------------------|------------------------------|-------------------------------------|--------|------|-----|----------|
| Symbol                  | Parameter                    | Test Conditions                     | Values |      |     | Units    |
|                         |                              |                                     | Min    | Typ  | Max |          |
| $C_{iss}$               | Input Capacitance            | $V_{DS}=42.5V, V_{GS}=0, f=1MHz$    | --     | 6234 | --  | pF       |
| $C_{oss}$               | Output Capacitance           |                                     | --     | 1181 | --  |          |
| $C_{rss}$               | Reverse Transfer Capacitance |                                     | --     | 97   | --  |          |
| $Q_g$                   | Total Gate Charge            | $V_{DD}=42.5V, I_D=50A, V_{GS}=10V$ | --     | 124  | --  | nC       |
| $Q_{gs}$                | Gate-Source charge           |                                     | --     | 31.2 | --  |          |
| $Q_{gd}$                | Gate-Drain charge            |                                     | --     | 39.2 | --  |          |
| $R_G$                   | Gate resistance              | $V_{GS}=0, V_{DS}=0$                |        | 1.75 |     | $\Omega$ |

| Switching Characteristics |                     |   |        |     |     |       |
|---------------------------|---------------------|---|--------|-----|-----|-------|
| Symbol                    | Parameter           | Test Conditions   | Values |     |     | Units |
|                           |                     |   | Min    | Typ | Max |       |
| $t_{d(on)}$               | Turn-On Delay Time  | $V_{DD}=42.5V, I_D=10A, V_{GS}=10V, R_G=3\Omega, \text{Resistive Load}$ | --     | 41  | --  | ns    |
| $t_r$                     | Rise Time           |   | --     | 68  | --  |       |
| $t_{d(off)}$              | Turn-Off Delay Time |   | --     | 76  | --  |       |
| $t_f$                     | Fall Time           |   | --     | 44  | --  |       |

| Source-Drain Diode Characteristics |                           |                                    |        |     |     |       |
|------------------------------------|---------------------------|------------------------------------|--------|-----|-----|-------|
| Symbol                             | Parameter                 | Test Conditions                    | Values |     |     | Units |
|                                    |                           |                                    | Min    | Typ | Max |       |
| $I_S$                              | Continuous Source Current |                                    | --     | --  | 120 | A     |
| $I_{SM}$                           | Maximum Pulsed Current    |                                    | --     | --  | 480 | A     |
| $V_{SD}$                           | Diode Forward Voltage     | $V_{GS}=0V, I_S=50A$               | --     | --  | 1.2 | V     |
| $T_{rr}$                           | Reverse Recovery Time     | $I_S=30A, V_{GS}=0, di/dt=100A/us$ | --     | 80  | --  | ns    |
| $Q_{rr}$                           | Reverse Recovery Charge   |                                    | --     | 112 | --  | nC    |



## 5. Characteristics Curves

Figure 1. Safe Operating Area

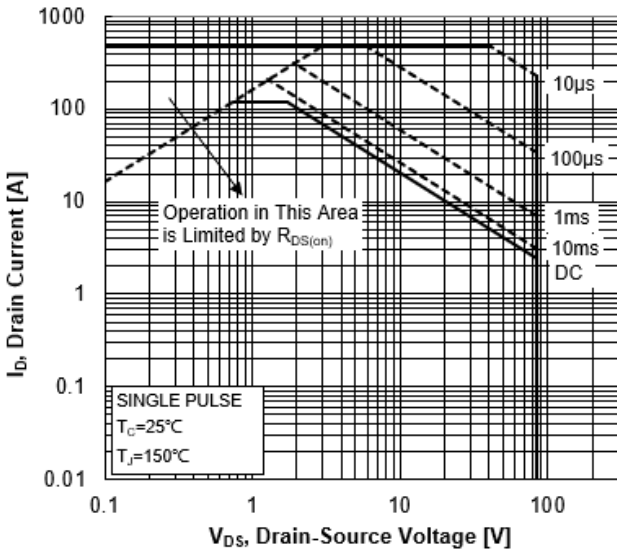


Figure 2. Maximum Power Dissipation vs Case Temperature

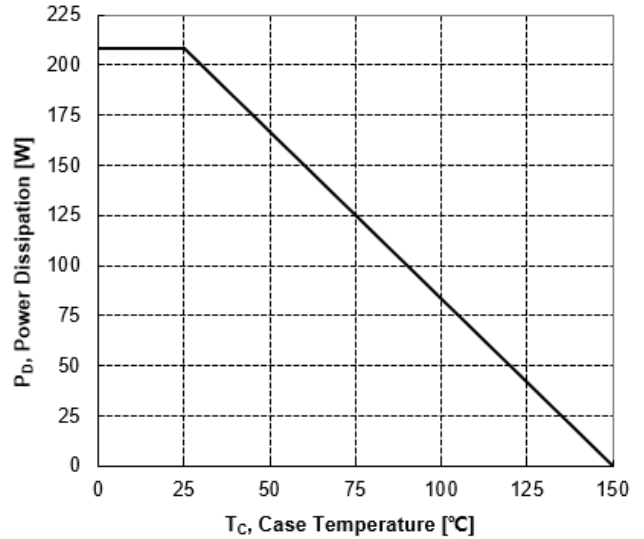


Figure 3. Maximum Continuous Drain Current vs Case Temperature

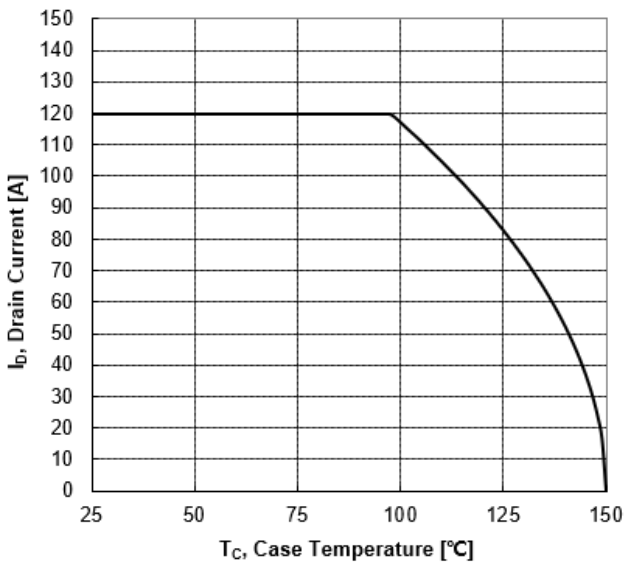
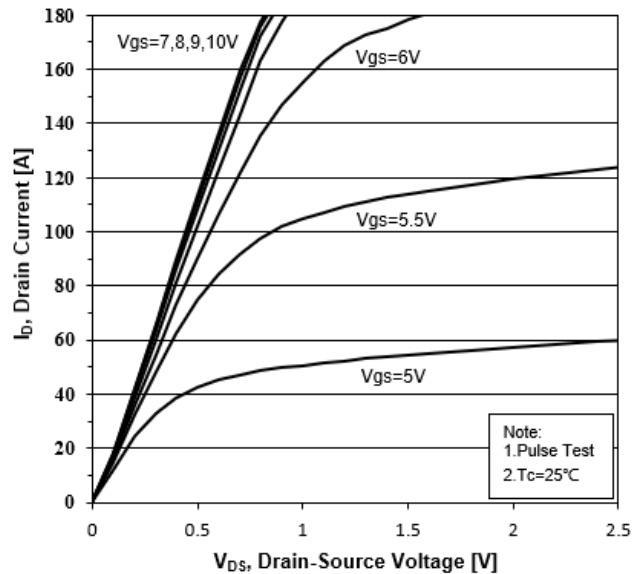
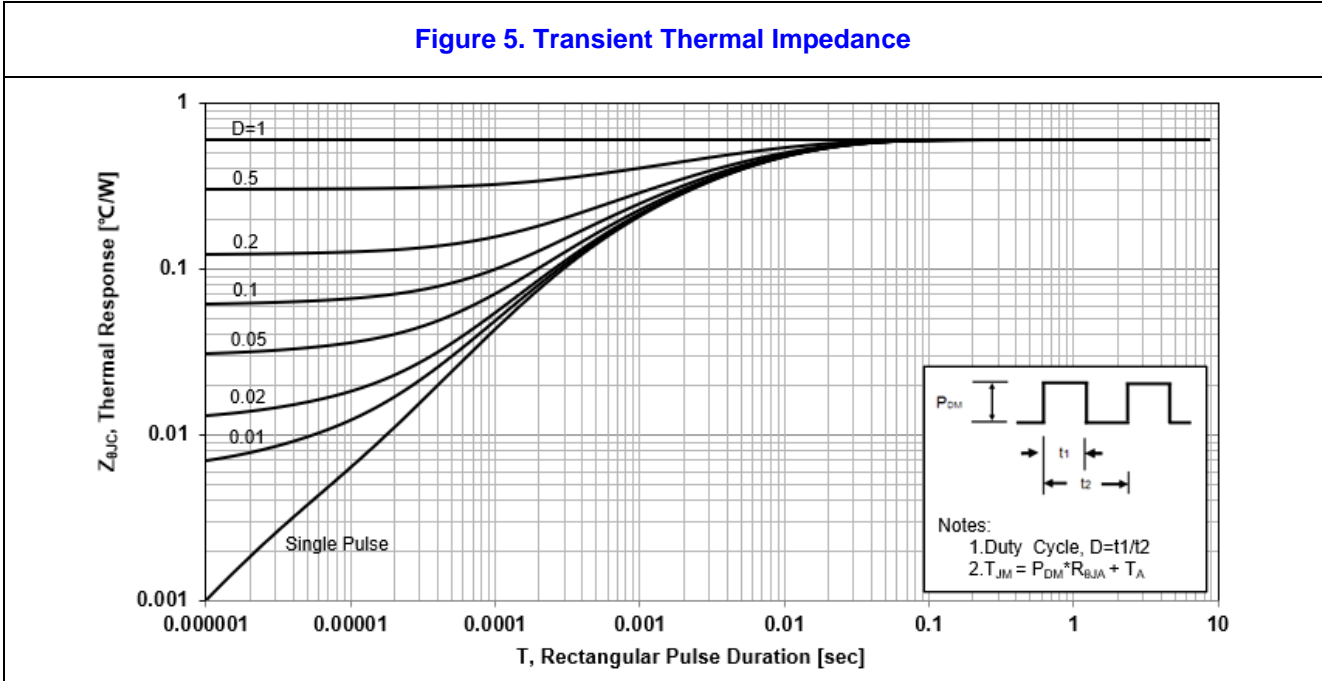


Figure 4. Typical Output Characteristics

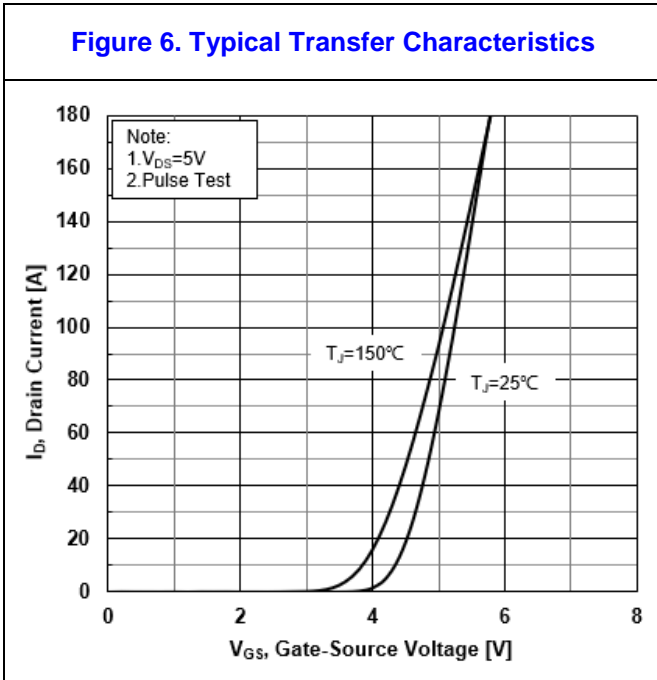




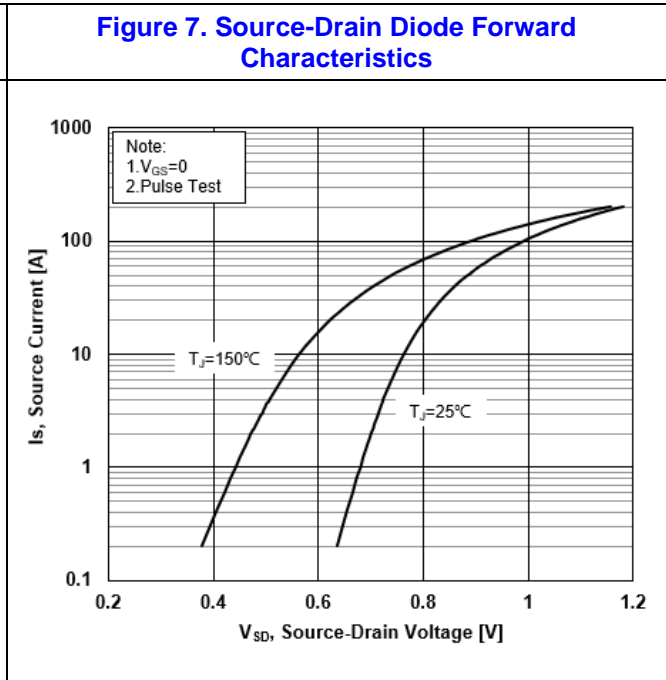
**Figure 5. Transient Thermal Impedance**



**Figure 6. Typical Transfer Characteristics**

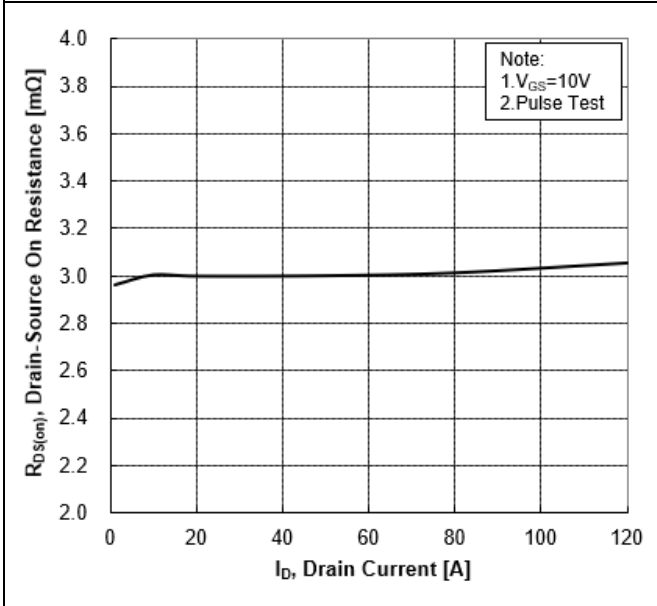


**Figure 7. Source-Drain Diode Forward Characteristics**

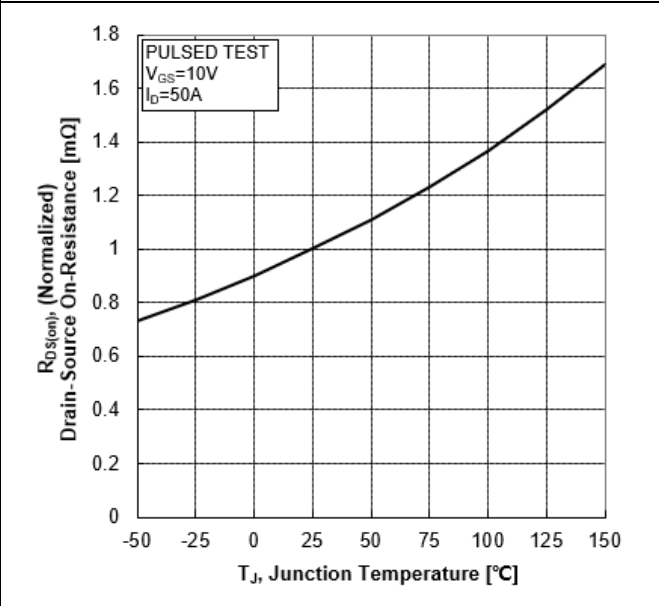




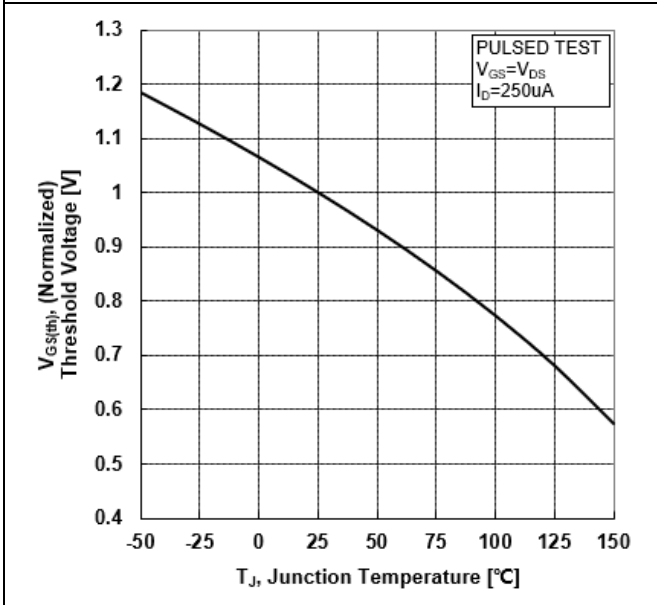
**Figure 8. Drain-Source On-Resistance vs Drain Current**



**Figure 9. Normalized On-Resistance vs Junction Temperature**



**Figure 10. Normalized Threshold Voltage vs Junction Temperature**



**Figure 11. Normalized Breakdown Voltage vs Junction Temperature**

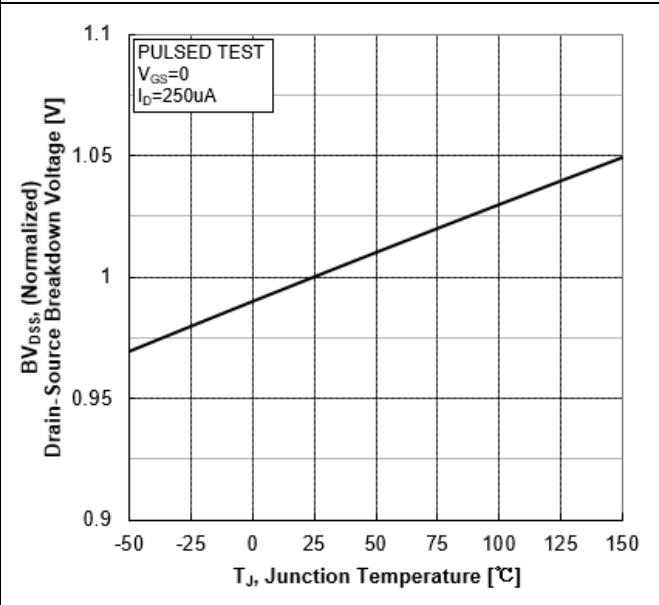




Figure 12. Capacitance Characteristics

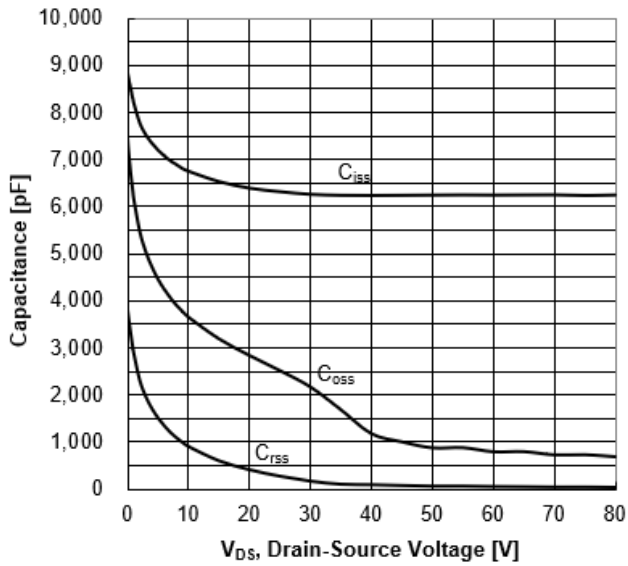
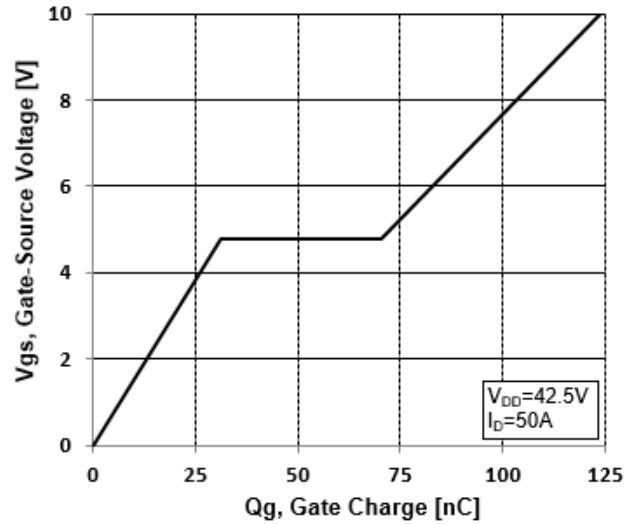


Figure 13. Typical Gate Charge vs Gate-Source Voltage



## 6. Test Circuit and Waveform

Figure 14. Resistive Switching Test Circuit

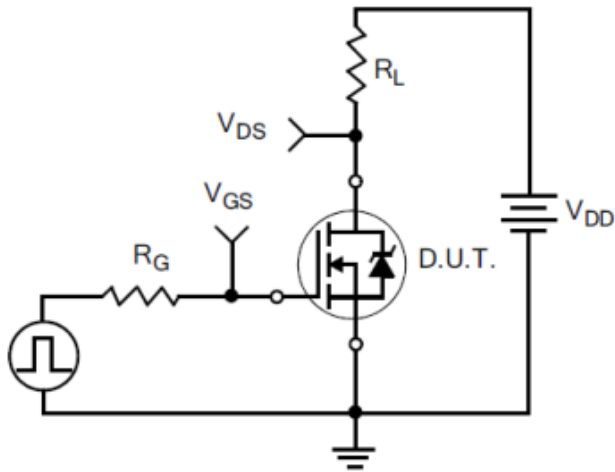


Figure 15. Resistive Switching Waveforms



Figure 16. Gate Charge Test Circuit

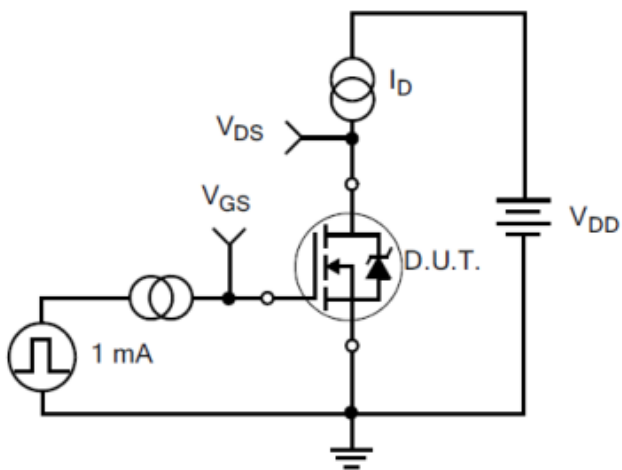


Figure 17. Gate Charge Waveforms

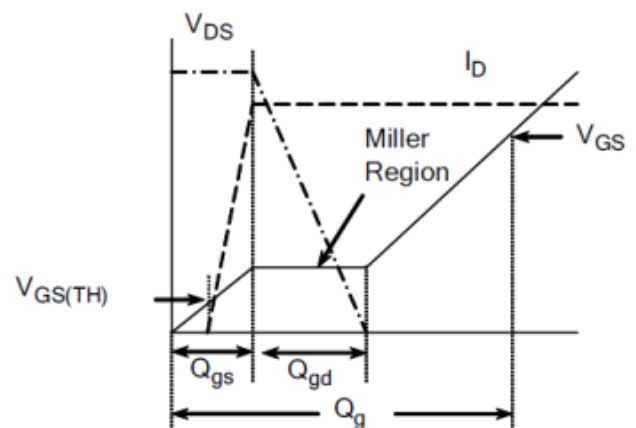




Figure 18. Diode Reverse Recovery Test Circuit

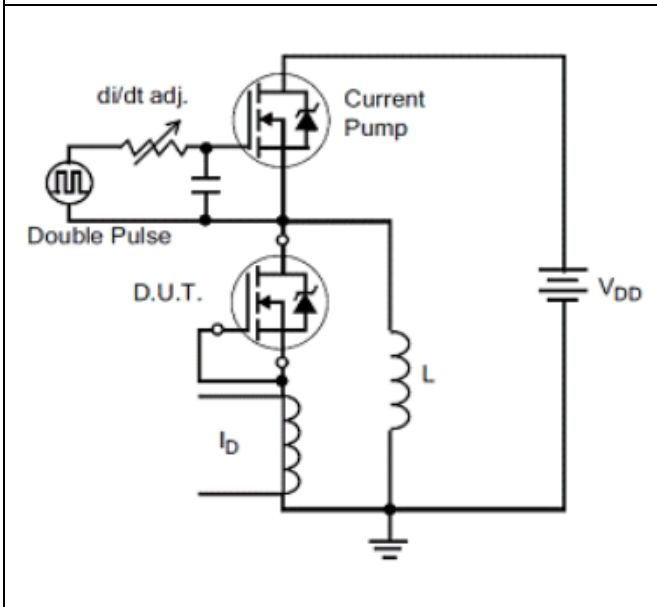


Figure 19. Diode Reverse Recovery Waveform

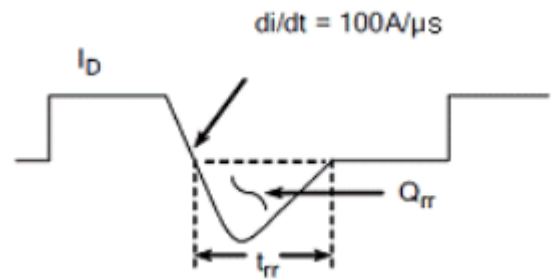


Figure 20. Unclamped Inductive Switching Test Circuit

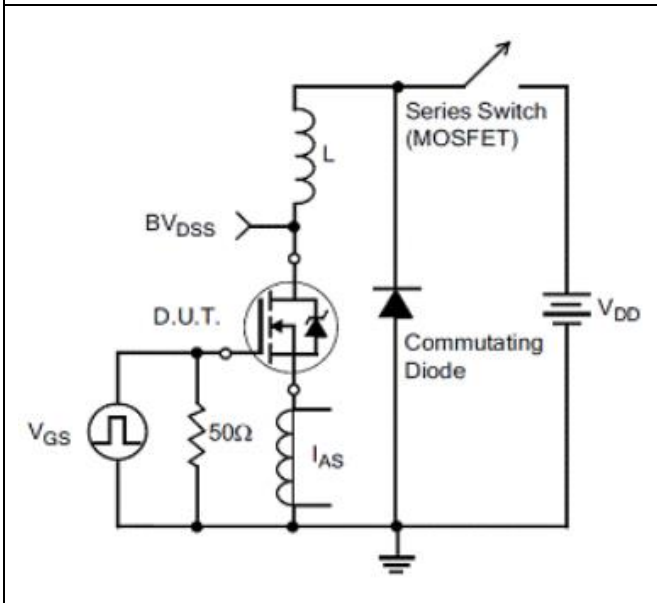
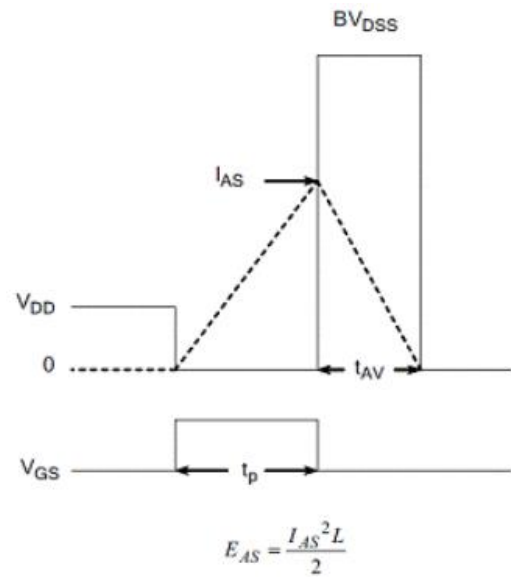
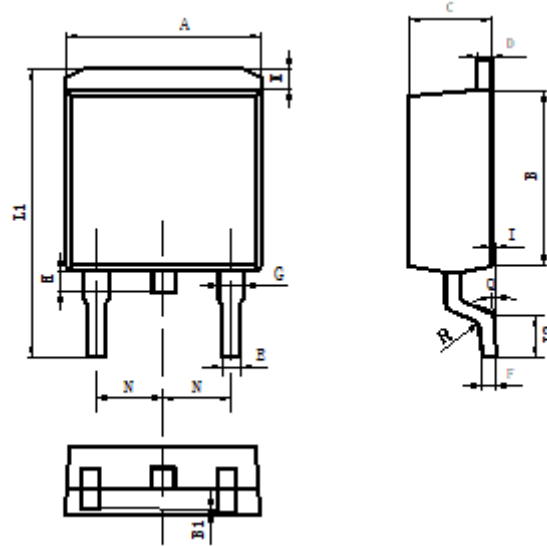


Figure 21. Unclamped Inductive Switching Waveform



## 7. Package Description

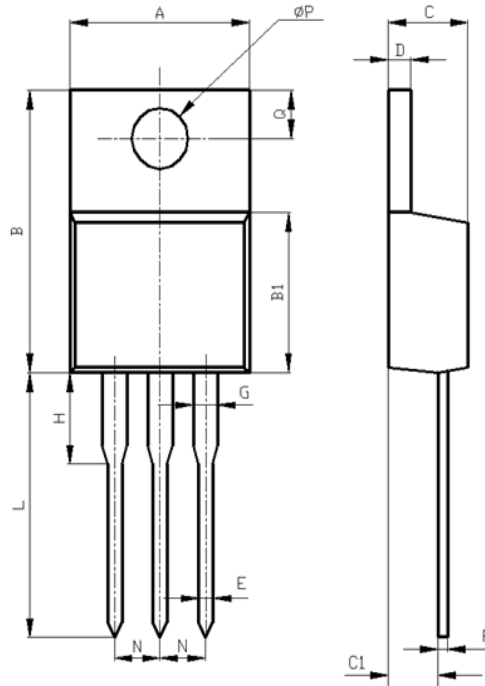
### TO-263



| Items | Values(mm) |       |
|-------|------------|-------|
|       | MIN        | MAX   |
| A     | 9.80       | 10.40 |
| B     | 8.90       | 9.50  |
| B1    | 0          | 0.10  |
| C     | 4.40       | 4.80  |
| D     | 1.16       | 1.37  |
| E     | 0.70       | 0.95  |
| F     | 0.30       | 0.60  |
| G     | 1.07       | 1.47  |
| H     | 1.30       | 1.80  |
| K     | 0.95       | 1.37  |
| L1    | 14.50      | 16.50 |
| L2    | 1.60       | 2.30  |
| I     | 0          | 0.2   |
| Q     | 0°         | 8°    |
| R     | 0.4        | 0.4   |
| N     | 2.39       | 2.69  |



TO-220



| Items    | Values(mm) |      |
|----------|------------|------|
|          | MIN        | MAX  |
| A        | 9.60       | 10.6 |
| B        | 15.0       | 16.0 |
| B1       | 8.90       | 9.50 |
| C        | 4.30       | 4.80 |
| C1       | 2.30       | 3.10 |
| D        | 1.20       | 1.40 |
| E        | 0.70       | 0.90 |
| F        | 0.30       | 0.60 |
| G        | 1.17       | 1.37 |
| H        | 2.70       | 3.80 |
| L        | 12.6       | 14.8 |
| N        | 2.34       | 2.74 |
| Q        | 2.40       | 3.00 |
| $\Phi P$ | 3.50       | 3.90 |



**NOTE:**

1. Exceeding the maximum ratings of the device in performance may cause damage to the device, even the permanent failure, which may affect the dependability of the machine. Please do not exceed the absolute maximum ratings of the device when circuit designing.
2. When installing the heat sink, please pay attention to the torsional moment and the smoothness of the heat sink.
3. MOSFETs is the device which is sensitive to the static electricity, it is necessary to protect the device from being damaged by the static electricity when using it.
4. Shanghai Jerrett reserves the right to make changes in this specification sheet and is subject to change without prior notice.