

## 1. Description

JRG05N08G, the N-channel Enhanced Power MOSFETs, is obtained by advanced double trench technology which reduce the conduction loss, improve switching performance and enhance the avalanche energy. This is suitable device for motor drivers and high speed switching applications.

### KEY CHARACTERISTICS

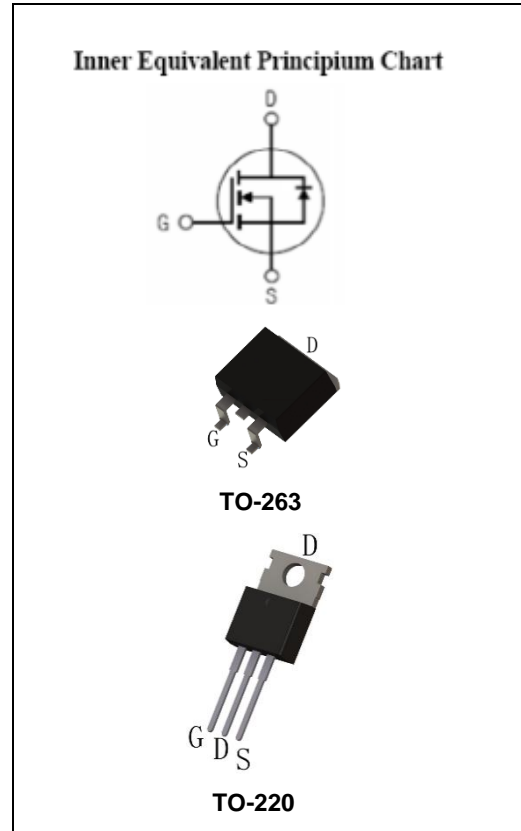
Parameter	Value	Unit
V <sub>DSS</sub>	85	V
I <sub>D</sub>	120	A
R <sub>DS(on).typ</sub>	4.4	mΩ

### FEATURES

- Fast Switching
- Low On-Resistance (  $R_{DS(on)} \leq 5m\Omega$  )
- Low Gate Charge
- Low Reverse transfer capacitances
- High avalanche ruggedness
- RoHS product

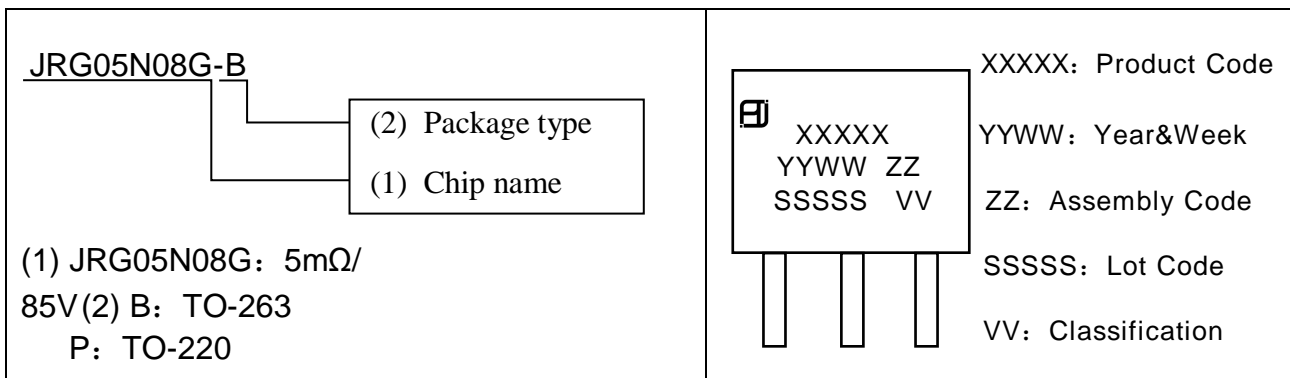
### APPLICATIONS

- Switching applications
- Motor drivers



### ORDERING INFORMATION

Ordering Codes	Package	Product Code	Packing
JRG05N08G-B	TO-263	P05N08G	Reel
JRG05N08G-P	TO-220	P05N08G	Tube



## 2. ABSOLUTE RATINGS

at  $T_C=25^\circ\text{C}$ , unless otherwise specified

Symbol	Parameter	Rating	Units
$V_{DSS}$	Drain-Source Voltage	85	V
$I_D$	Continuous Drain Current, Silicon Limited	138	A
	Continuous Drain Current, Package Limited	120	A
	Continuous Drain Current @ $T_C=100^\circ\text{C}$ , Silicon Limited	87.4	A
$I_{DM}$ <sup>Note1</sup>	Pulsed Drain Current	480	A
$V_{GS}$	Gate-Source Voltage	$\pm 20$	V
$E_{AS}$ <sup>Note2</sup>	Avalanche Energy	169	mJ
$P_D$	Power Dissipation	173.6	W
	Derating Factor above $25^\circ\text{C}$	1.39	W/ $^\circ\text{C}$
$T_J, T_{stg}$	Operating Junction and Storage Temperature Range	150, $-55$ to $150$	$^\circ\text{C}$
$T_L$	Maximum Temperature for Soldering	260	$^\circ\text{C}$

Note1: Repetitive Rating: Pulse width limited by maximum junction temperature

Note2:  $L=0.5\text{mH}$ ,  $I_{as}=26\text{A}$ , Start  $T_J=25^\circ\text{C}$

## 3. Thermal characteristics

Symbol	Parameter	Max	Units
$R_{\theta JC}$	thermal resistance, Junction-Case	0.72	$^\circ\text{C}/\text{W}$
$R_{\theta JA}$	thermal resistance, Junction-Ambient	62.5	$^\circ\text{C}/\text{W}$

## 4. Electrical Characteristics

at  $T_C=25^\circ\text{C}$ , unless otherwise specified

OFF Characteristics						
Symbol	Parameter	Test Conditions	Values			Units
			Min	Typ	Max	
$V_{DSS}$	Drain-Source Breakdown Voltage	$V_{GS}=0\text{V}, I_D=250\mu\text{A}$	85	--	--	V
$I_{DSS}$	Drain-Source Leakage Current	$V_{DS}=85\text{V}, V_{GS}=0\text{V}$	--	--	1	$\mu\text{A}$
		$V_{DS}=68\text{V}, V_{GS}=0\text{V}$ @ $T_C=125^\circ\text{C}$	--	--	100	$\mu\text{A}$
$I_{GSS(F)}$	Gate-Source Forward Leakage	$V_{GS}=+20\text{V}$	--	--	100	nA
$I_{GSS(R)}$	Gate-Source Reverse Leakage	$V_{GS}=-20\text{V}$	--	--	-100	nA

ON Characteristics						
Symbol	Parameter	Test Conditions	Values			Unit S
			Min	Typ	Max	
$R_{DS(on)}$	Drain-Source On-Resistance	$V_{GS}=10V, I_D=50A$	--	4.4	5	m $\Omega$
$V_{GS(th)}$	Gate Threshold Voltage	$V_{DS}=V_{GS}, I_D=250\mu A$	2.0	3.0	4.0	V
Pulse width $t_p \leq 300\mu s, \delta \leq 2\%$						

Dynamic Characteristics						
Symbol	Parameter	Test Conditions	Values			Units
			Min	Typ	Max	
$C_{iss}$	Input Capacitance	$V_{DS}=40V,$ $V_{GS}=0,$ $f=1MHz$	--	4021	--	pF
$C_{oss}$	Output Capacitance		--	637	--	
$C_{rss}$	Reverse Transfer Capacitance		--	17	--	
$Q_g$	Total Gate Charge	$V_{DD}=40V,$ $I_D=50A,$ $V_{GS}=10V$	--	80	--	nC
$Q_{gs}$	Gate-Source charge		--	23	--	
$Q_{gd}$	Gate-Drain charge		--	24	--	

Switching Characteristics						
Symbol	Parameter	Test Conditions	Values			Units
			Min	Typ	Max	
$t_{d(on)}$	Turn-On Delay Time	$V_{DD}=40V,$ $I_D=50A,$ $V_{GS}=10V,$ $R_G=3\Omega,$ Resistive Load	--	22	--	ns
$t_r$	Rise Time		--	42	--	
$t_{d(off)}$	Turn-Off Delay Time		--	48	--	
$t_f$	Fall Time		--	25	--	

Source-Drain Diode Characteristics						
Symbol	Parameter	Test Conditions	Values			Units
			Min	Typ	Max	
$I_S$	Continuous Source Current		--	--	120	A
$I_{SM}$	Maximum Pulsed Current		--	--	480	A
$V_{SD}$	Diode Forward Voltage	$V_{GS}=0V, I_S=50A$	--	--	1.2	V
$T_{rr}$	Reverse Recovery Time	$I_S=20A,$ $di/dt=100A/us$	--	60	--	ns
$Q_{rr}$	Reverse Recovery Charge		--	136	--	nC



## 5. Characteristics Curves

Figure 1. Safe Operating Area

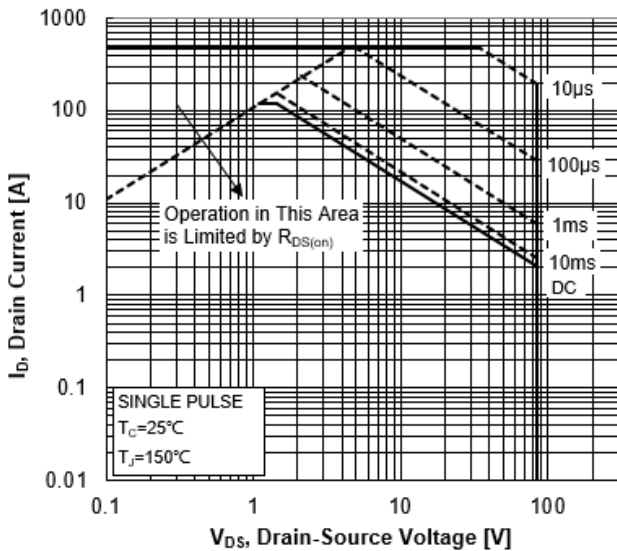


Figure 2. Maximum Power Dissipation vs Case Temperature

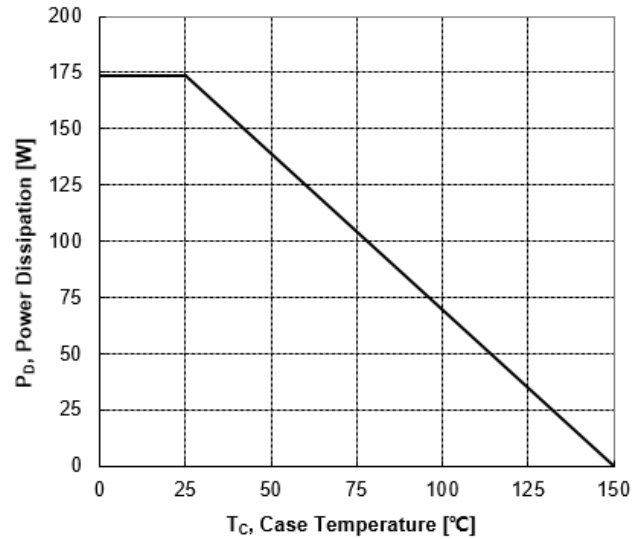


Figure 3. Maximum Continuous Drain Current vs Case Temperature

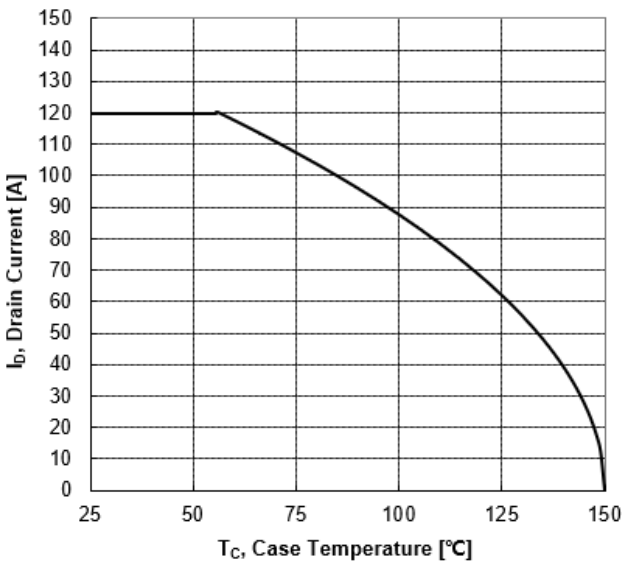
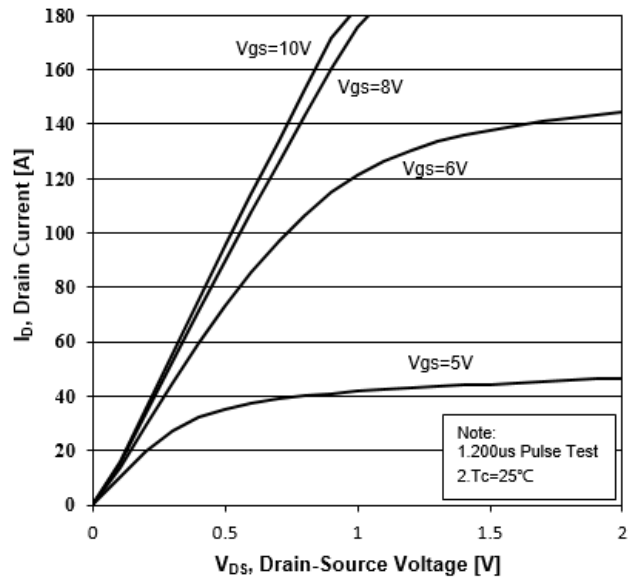
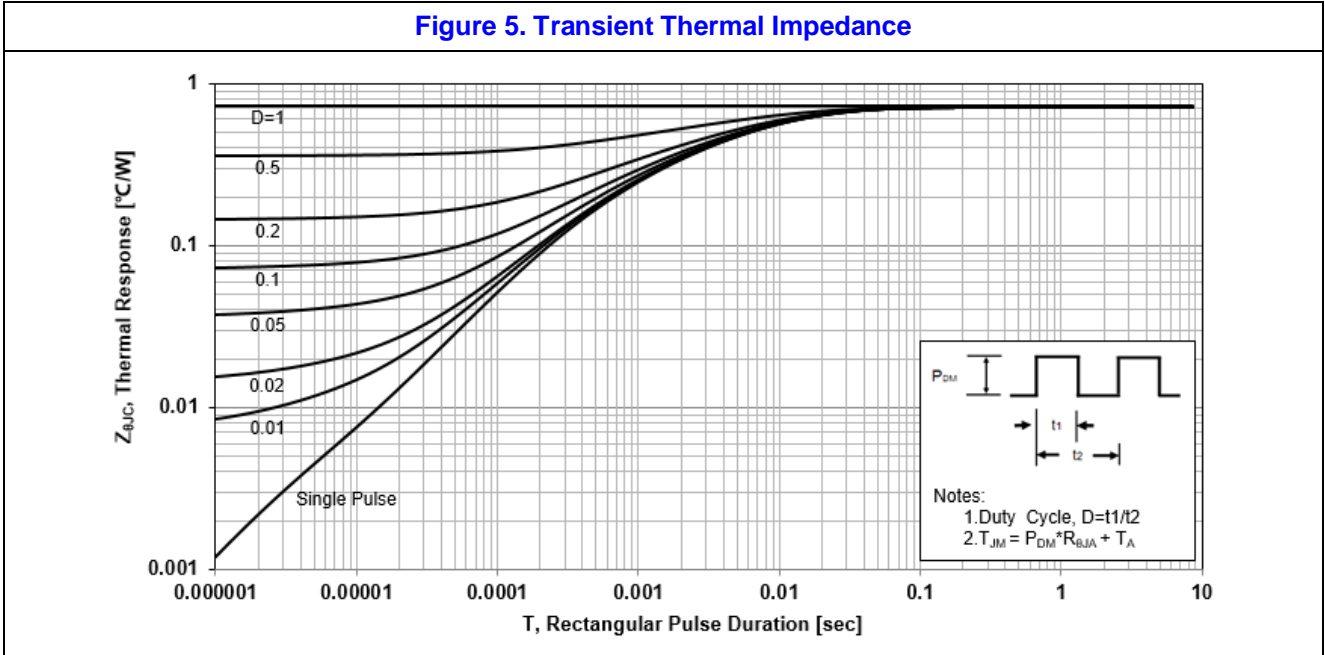


Figure 4. Typical Output Characteristics

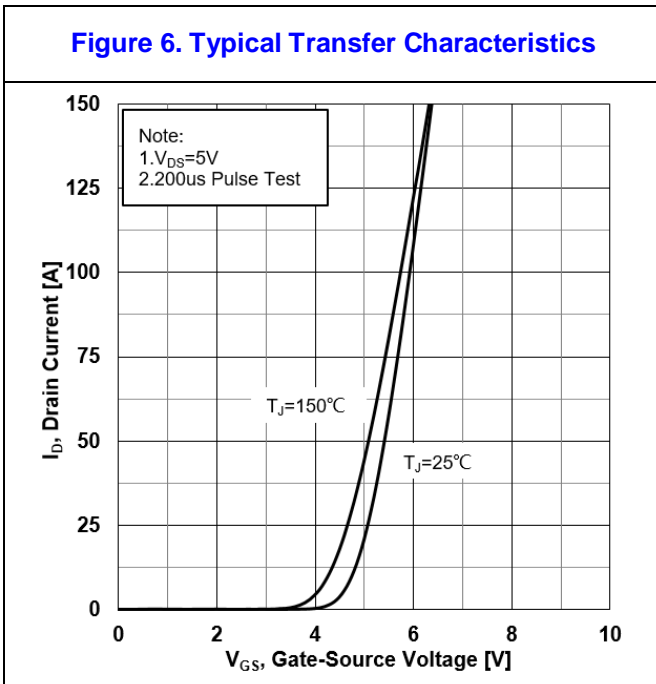




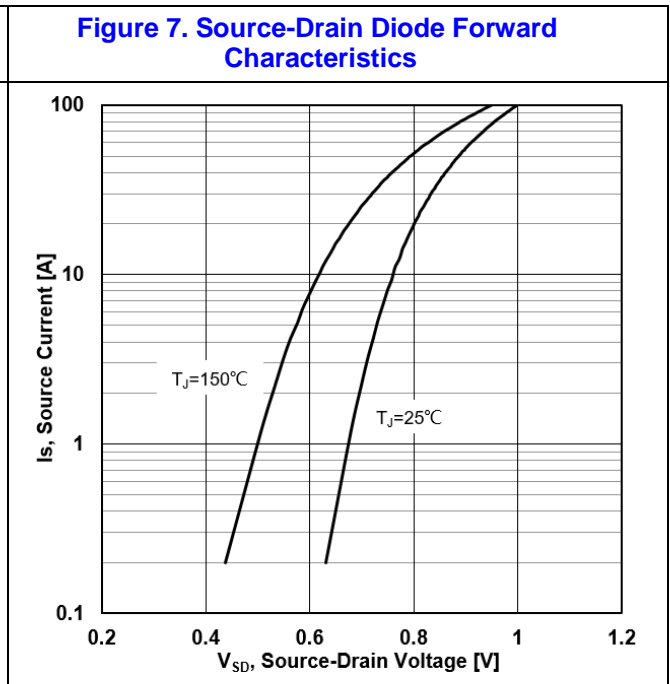
**Figure 5. Transient Thermal Impedance**



**Figure 6. Typical Transfer Characteristics**

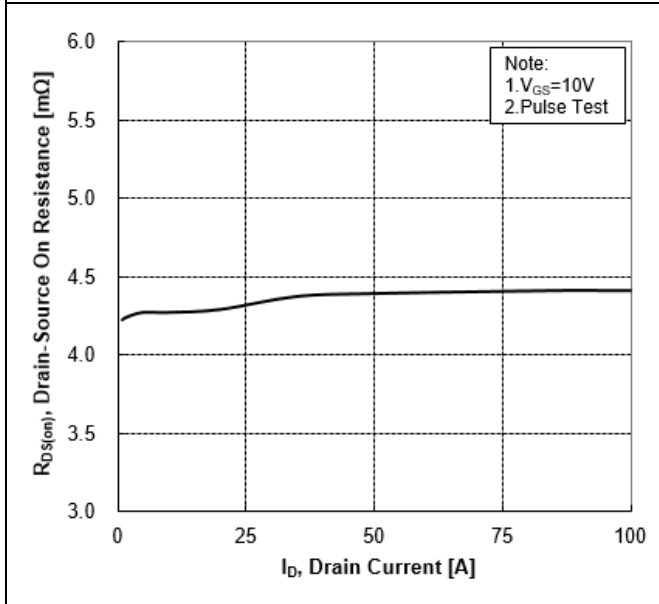


**Figure 7. Source-Drain Diode Forward Characteristics**

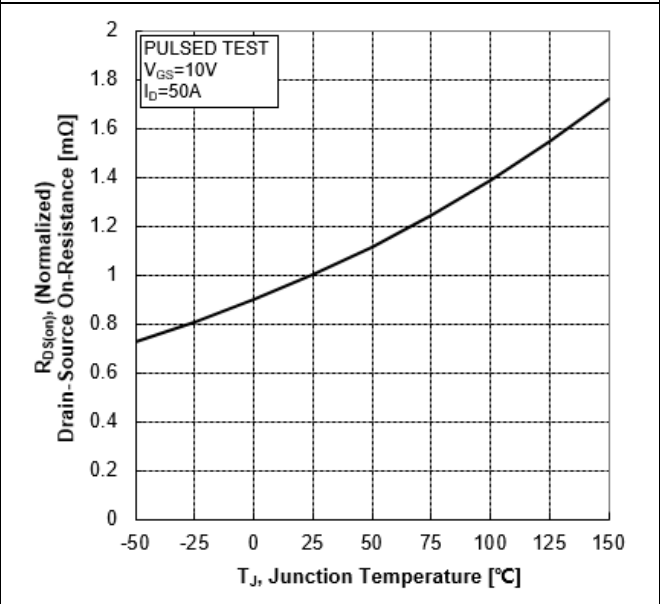




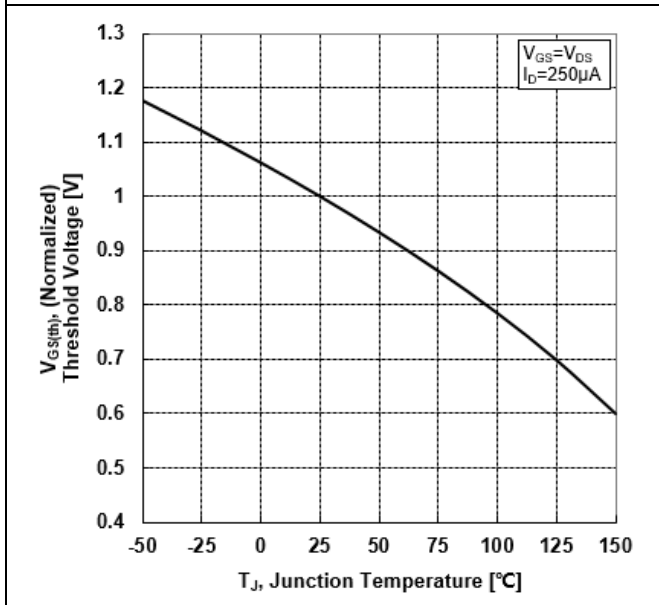
**Figure 8. Drain-Source On-Resistance vs Drain Current**



**Figure 9. Normalized On-Resistance vs Junction Temperature**



**Figure 10. Normalized Threshold Voltage vs Junction Temperature**



**Figure 11. Normalized Breakdown Voltage vs Junction Temperature**

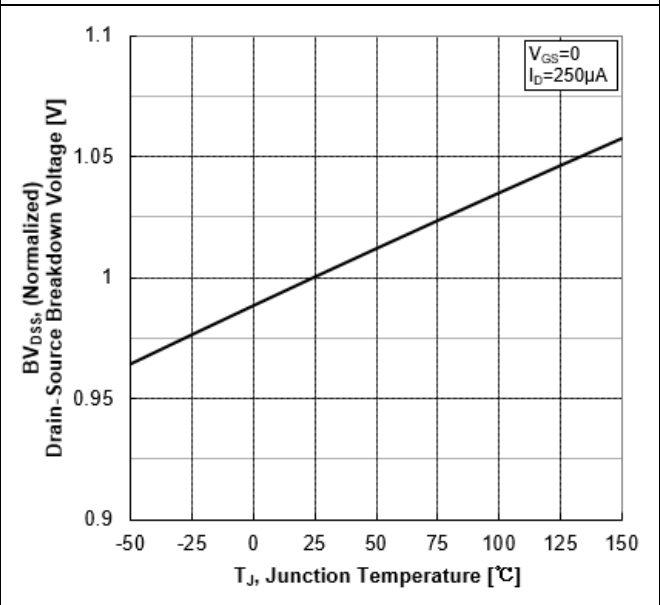




Figure 12. Capacitance Characteristics

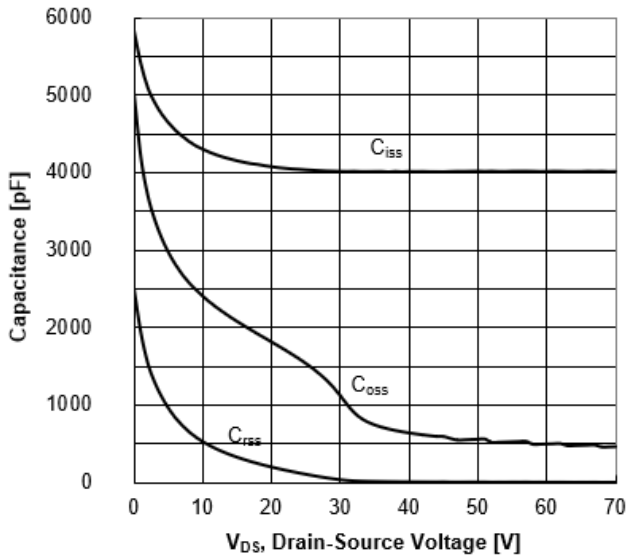
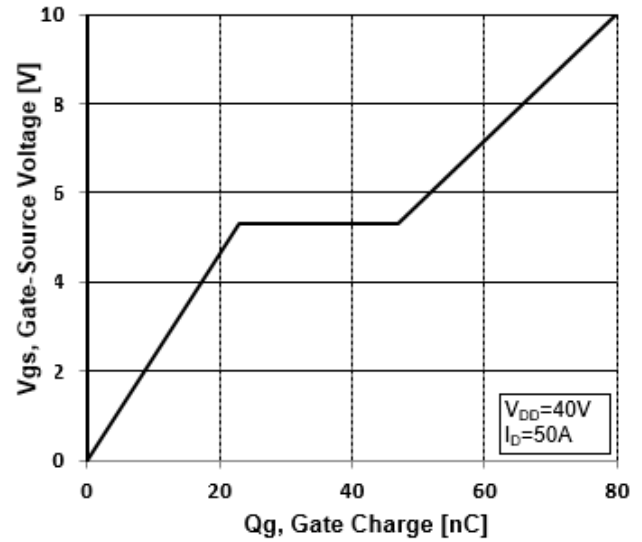


Figure 13. Typical Gate Charge vs Gate-Source Voltage



## 6. Test Circuit and Waveform

Figure 14. Resistive Switching Test Circuit

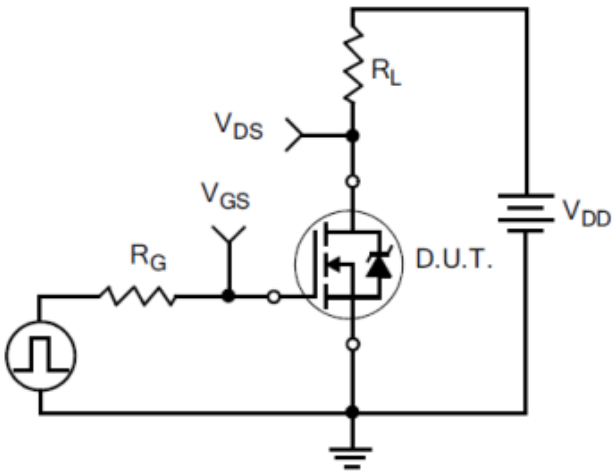


Figure 15. Resistive Switching Waveforms



Figure 16. Gate Charge Test Circuit

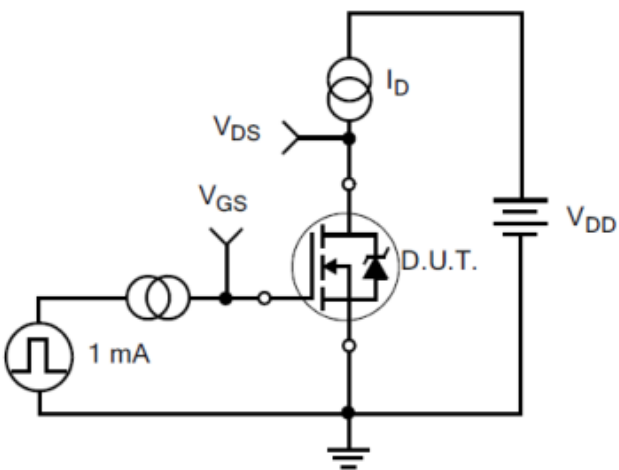


Figure 17. Gate Charge Waveforms





Figure 18. Diode Reverse Recovery Test Circuit

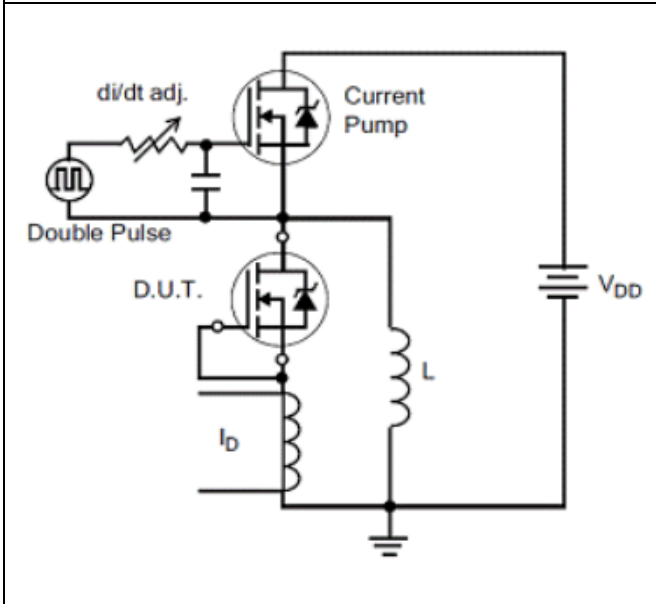


Figure 19. Diode Reverse Recovery Waveform

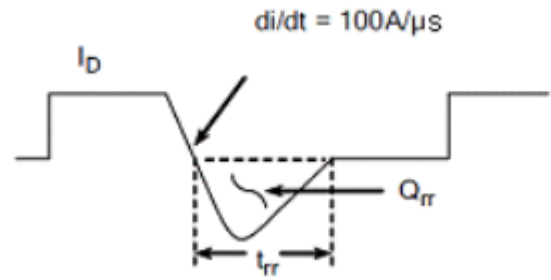


Figure 20. Unclamped Inductive Switching Test Circuit

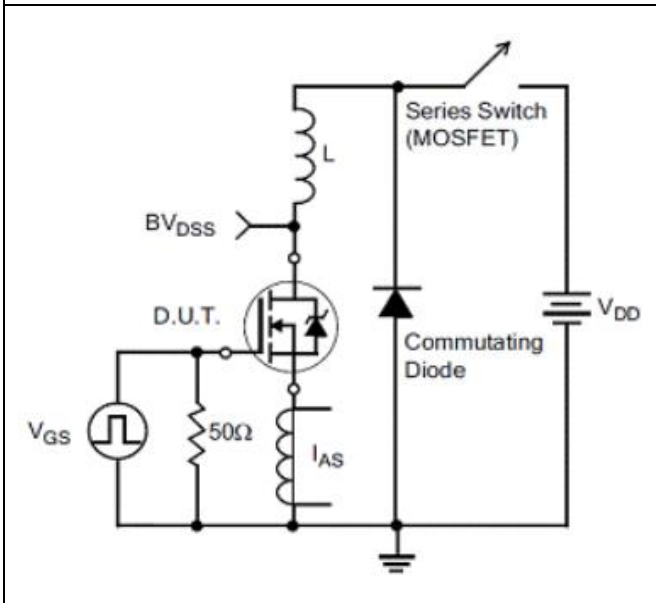
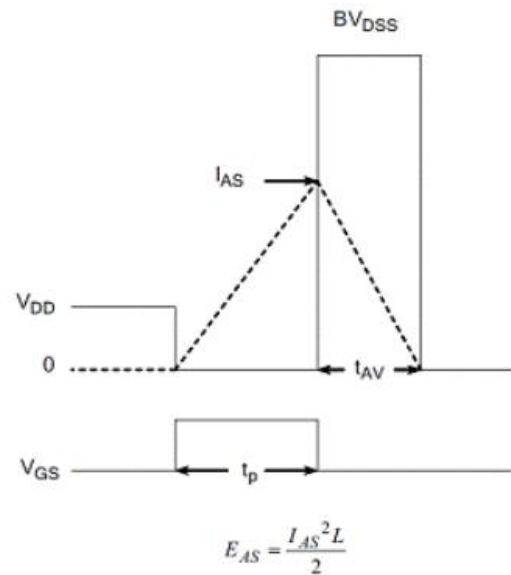
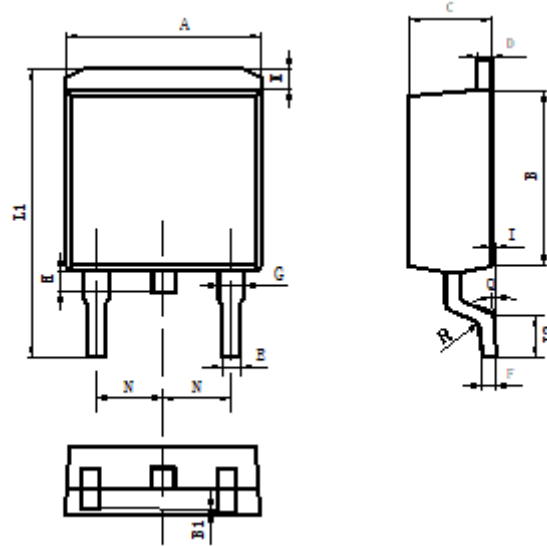


Figure 21. Unclamped Inductive Switching Waveform



## 7. Package Description

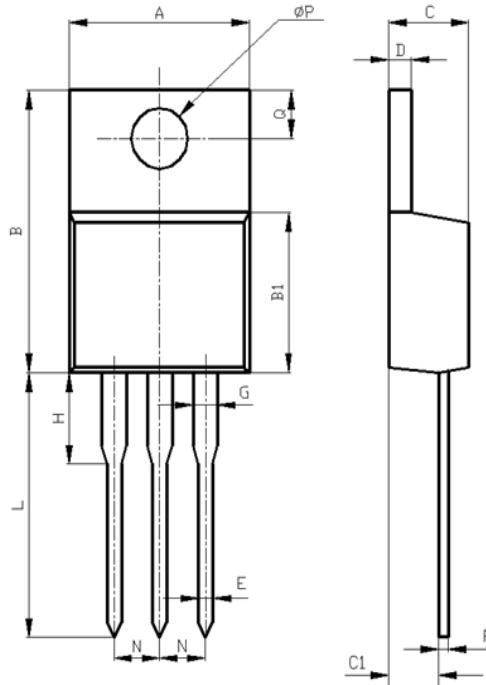
### TO-263 Package



Items	Values(mm)	
	MIN	MAX
A	9.80	10.40
B	8.90	9.50
B1	0	0.10
C	4.40	4.80
D	1.16	1.37
E	0.70	0.95
F	0.30	0.60
G	1.07	1.47
H	1.30	1.80
K	0.95	1.37
L1	14.50	16.50
L2	1.60	2.30
I	0	0.2
Q	0°	8°
R	0.4	0.4
N	2.39	2.69



TO-220 Package



Items	Values(mm)	
	MIN	MAX
A	9.60	10.6
B	15.0	16.0
B1	8.90	9.50
C	4.30	4.80
C1	2.30	3.10
D	1.20	1.40
E	0.70	0.90
F	0.30	0.60
G	1.17	1.37
H	2.70	3.80
L	12.6	14.8
N	2.34	2.74
Q	2.40	3.00
ΦP	3.50	3.90



**NOTE:**

1. Exceeding the maximum ratings of the device in performance may cause damage to the device, even the permanent failure, which may affect the dependability of the machine. Please do not exceed the absolute maximum ratings of the device when circuit designing.
2. When installing the heat sink, please pay attention to the torsional moment and the smoothness of the heat sink.
3. MOSFETs is the device which is sensitive to the static electricity, it is necessary to protect the device from being damaged by the static electricity when using it.
4. Shanghai Jerrett reserves the right to make changes in this specification sheet and is subject to change without prior notice.