

1. Description

JRP14N08L, the N-channel Enhanced Power MOSFETs, is obtained by advanced double trench technology which reduce the conduction loss, and improve switching performance. This is suitable device for LED backlighting and high speed switching applications.

KEY CHARACTERISTICS

Parameter	Value	Unit
V _{DSS}	80	V
I _D	32	A
R _{DS(on).typ}	13.8	mΩ

FEATURES

- Fast Switching
- Low On-Resistance
- Low Gate Charge
- Low Reverse transfer capacitances
- High avalanche ruggedness
- RoHS product

APPLICATIONS

- Switching applications
- LED backlighting

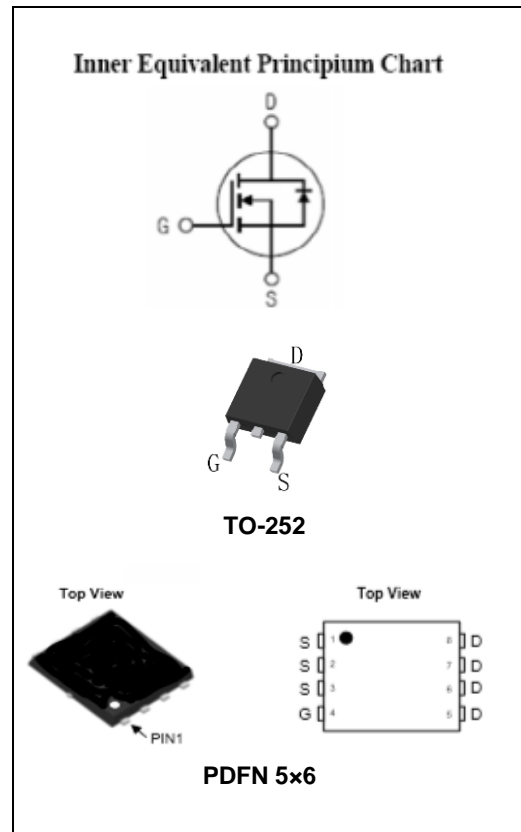

ORDERING INFORMATION

Ordering Codes	Package	Product Code	Packing
JRP14N08L-D	TO-252	P14N08L	Reel
JRP14N08L-Q	PDFN 5x6	P14N08L	Reel

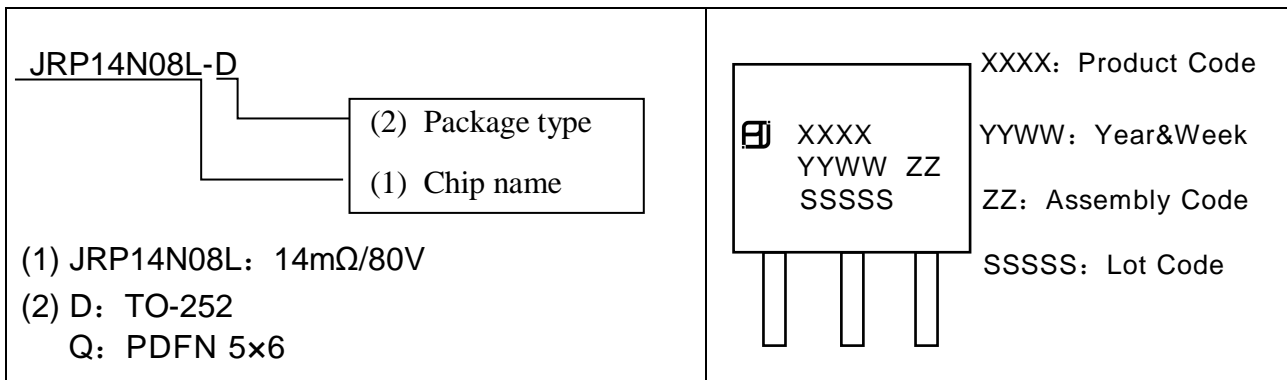

2. ABSOLUTE RATINGS

at $T_C=25^{\circ}\text{C}$, unless otherwise specified

Symbol	Parameter	Rating	Units
V_{DSS}	Drain-Source Voltage	80	V
I_D	Continuous Drain Current, Silicon Limited	32	A
	Continuous Drain Current, TO-252 Package Limited	60	A
	Continuous Drain Current, PDFN 5x6 Package Limited	35	A
	Continuous Drain Current @ $T_C=100^{\circ}\text{C}$, Silicon Limited	20.7	A
I_{DM} ^{Note1}	Pulsed Drain Current	128	A
V_{GS}	Gate-Source Voltage	± 20	V
E_{AS} ^{Note2}	Avalanche Energy	25	mJ
P_D	Power Dissipation	31.2	W
	Derating Factor above 25°C	0.25	W/ $^{\circ}\text{C}$
T_J, T_{stg}	Operating Junction and Storage Temperature Range	150, -55 to 150	$^{\circ}\text{C}$
T_L	Maximum Temperature for Soldering	260	$^{\circ}\text{C}$

Note1: Repetitive Rating: Pulse width limited by maximum junction temperature

Note2: $L=0.5\text{mH}$, $I_{as}=10\text{A}$, Start $T_J=25^{\circ}\text{C}$

3. Thermal characteristics

Symbol	Parameter	Max	Units
$R_{\theta JC}$	thermal resistance, Junction-Case	4	$^{\circ}\text{C}/\text{W}$
$R_{\theta JA}$	thermal resistance, Junction-Ambient	75	$^{\circ}\text{C}/\text{W}$

4. Electrical Characteristics

at $T_C=25^{\circ}\text{C}$, unless otherwise specified

OFF Characteristics						
Symbol	Parameter	Test Conditions	Values			Units
			Min	Typ	Max	
V_{DSS}	Drain-Source Breakdown Voltage	$V_{GS}=0\text{V}, I_D=250\mu\text{A}$	80	90	--	V
I_{DSS}	Drain-Source Leakage Current	$V_{DS}=80\text{V}, V_{GS}=0\text{V}$	--	--	1	μA
		$V_{DS}=64\text{V}, V_{GS}=0\text{V}$ @ $T_C=125^{\circ}\text{C}$	--	--	100	μA
$I_{GSS(F)}$	Gate-Source Forward Leakage	$V_{GS}=+20\text{V}$	--	--	100	nA
$I_{GSS(R)}$	Gate-Source Reverse Leakage	$V_{GS}=-20\text{V}$	--	--	-100	nA



ON Characteristics						
Symbol	Parameter	Test Conditions	Values			Units
			Min	Typ	Max	
$R_{DS(on)}$	Drain-Source On-Resistance	$V_{GS}=4.5V, I_D=20A$	--	21	23	$m\Omega$
		$V_{GS}=10V, I_D=20A$	--	13.8	15	
$V_{GS(th)}$	Gate Threshold Voltage	$V_{DS}=V_{GS}, I_D=250\mu A$	1	1.8	2.5	V
Pulse width $t_p \leq 300\mu s, \delta \leq 2\%$						

Dynamic Characteristics						
Symbol	Parameter	Test Conditions	Values			Units
			Min	Typ	Max	
C_{iss}	Input Capacitance	$V_{DS}=40V,$ $V_{GS}=0,$ $f=1MHz$	--	1053	--	pF
C_{oss}	Output Capacitance		--	186	--	
C_{rss}	Reverse Transfer Capacitance		--	6.5	--	
Q_g	Total Gate Charge	$V_{DD}=40V,$ $I_D=10A,$ $V_{GS}=10V$	--	22.4	--	nC
Q_{gs}	Gate-Source charge		--	4.3	--	
Q_{gd}	Gate-Drain charge		--	4	--	
R_G	Gate resistance	$V_{GS}=0, V_{DS}=0$		1		Ω

Switching Characteristics						
Symbol	Parameter	Test Conditions	Values			Units
			Min	Typ	Max	
$t_{d(on)}$	Turn-On Delay Time	$V_{DD}=40V,$ $I_D=10A,$ $V_{GS}=10V,$ $R_G=5\Omega,$ Resistive Load	--	9.8	--	ns
t_r	Rise Time		--	5	--	
$t_{d(off)}$	Turn-Off Delay Time		--	18.6	--	
t_f	Fall Time		--	3.9	--	

Source-Drain Diode Characteristics						
Symbol	Parameter	Test Conditions	Values			Units
			Min	Typ	Max	
I_S	Continuous Source Current		--	--	32	A
I_{SM}	Maximum Pulsed Current		--	--	128	A
V_{SD}	Diode Forward Voltage	$V_{GS}=0V, I_S=20A$	--	--	1.2	V
T_{rr}	Reverse Recovery Time	$I_S=20A, V_{GS}=0,$ $di/dt=500A/us$	--	35	--	ns
Q_{rr}	Reverse Recovery Charge		--	136	--	nC



5. Characteristics Curves

Figure 1. Safe Operating Area

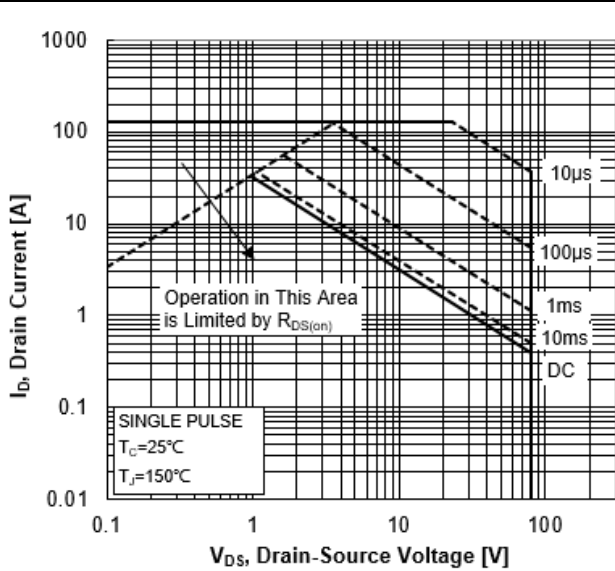

Figure 2. Maximum Power Dissipation vs Case Temperature

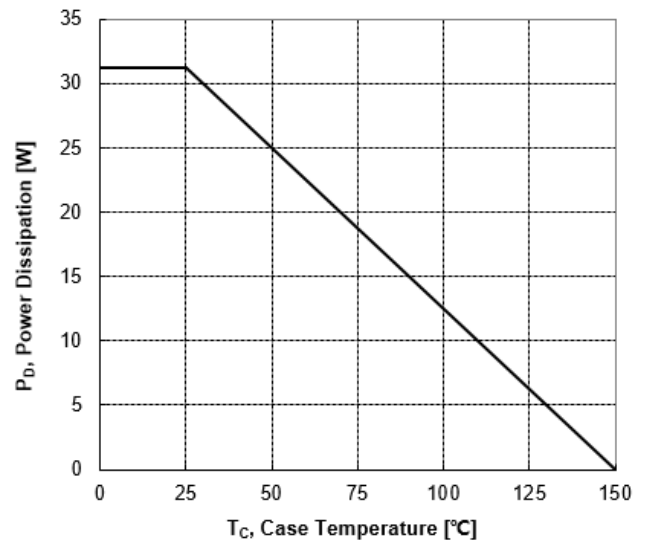

Figure 3. Maximum Continuous Drain Current vs Case Temperature

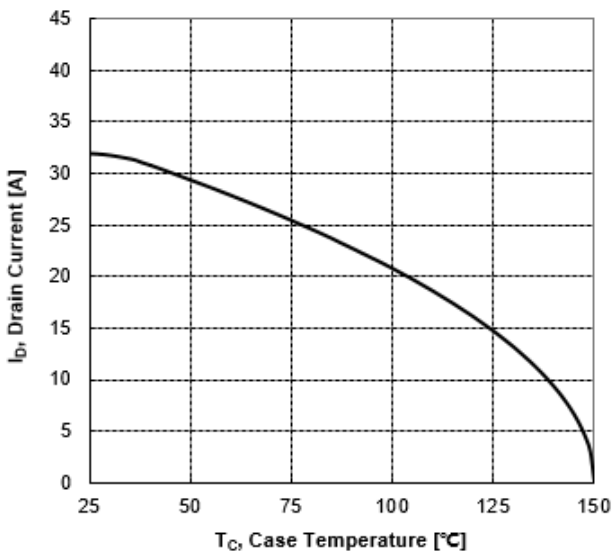

Figure 4. Typical Output Characteristics

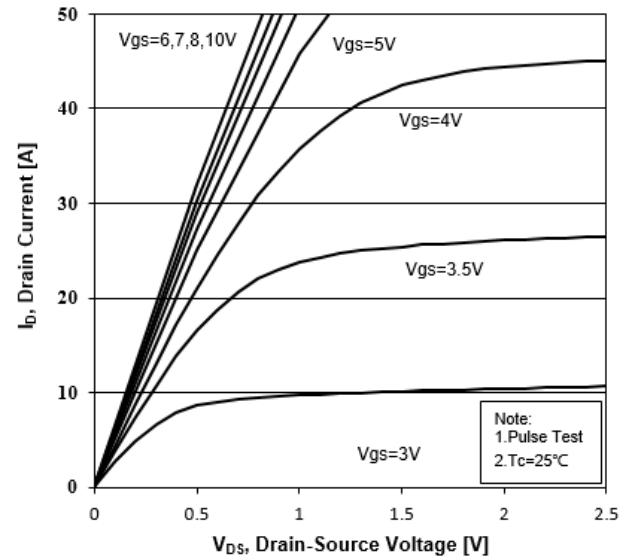



Figure 5. Transient Thermal Impedance

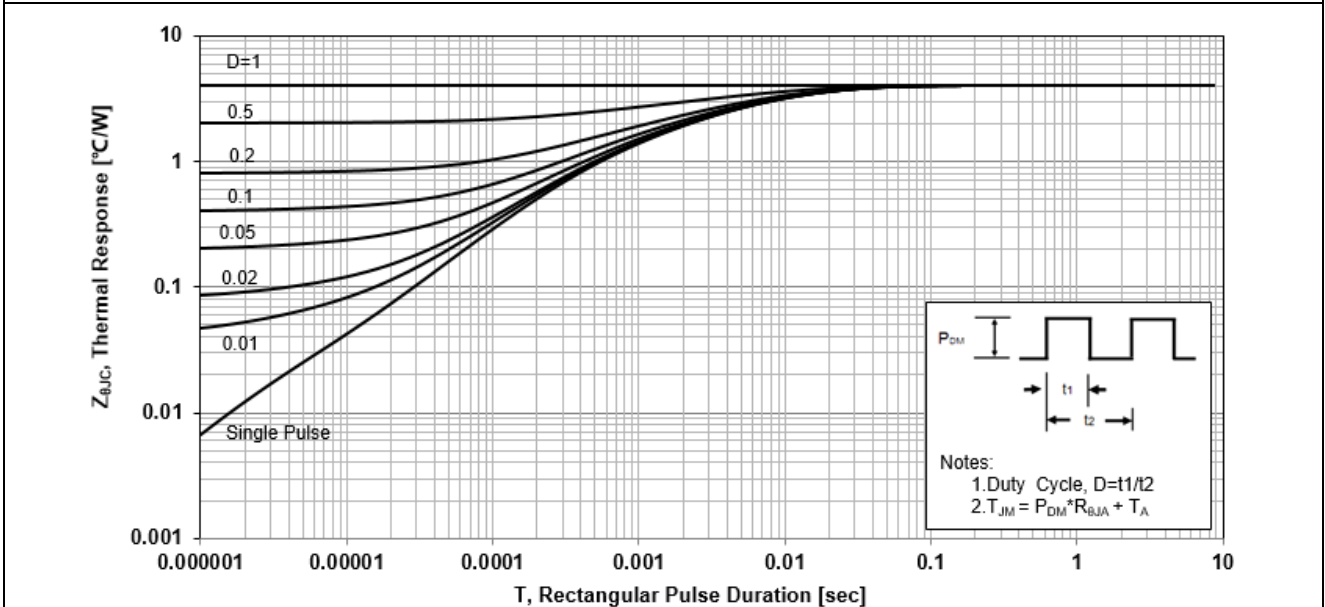

Figure 6. Typical Transfer Characteristics

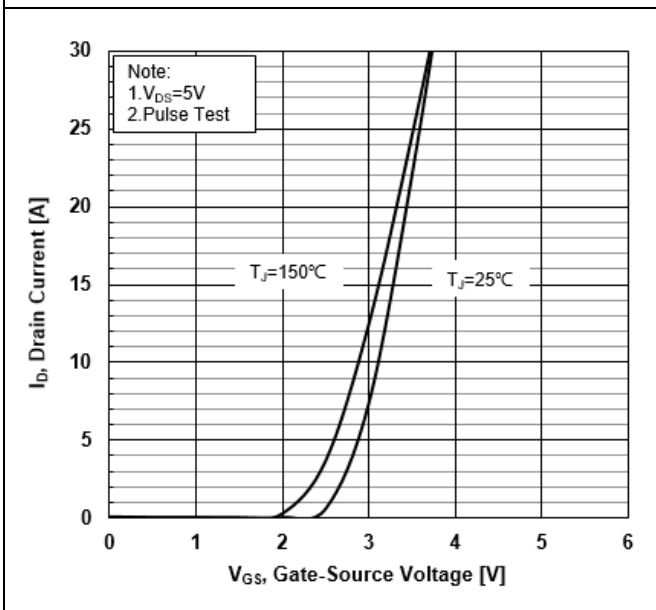

Figure 7. Source-Drain Diode Forward Characteristics

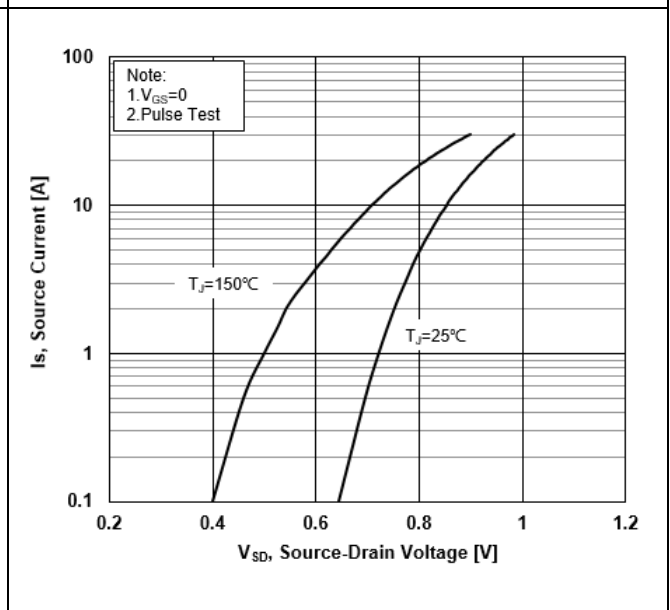



Figure 8. Drain-Source On-Resistance vs Drain Current

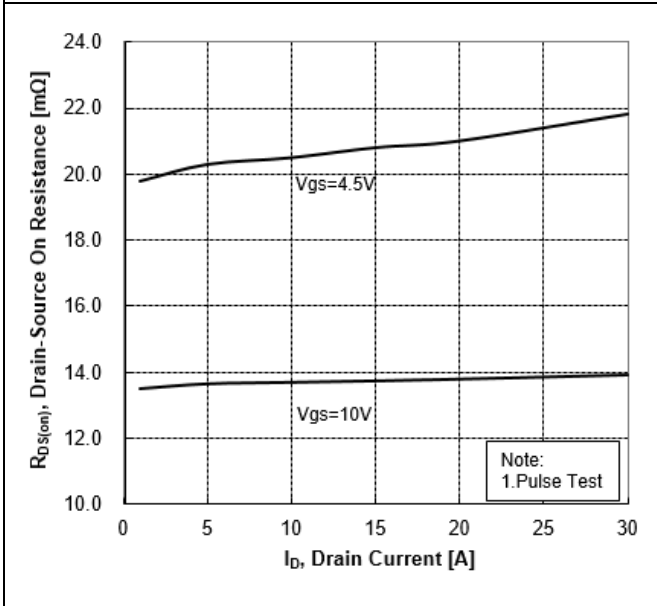

Figure 9. Normalized On-Resistance vs Junction Temperature

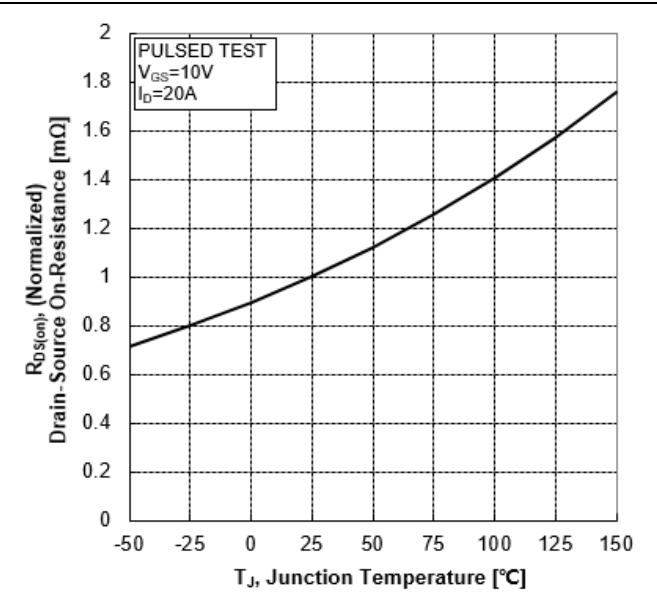

Figure 10. Normalized Threshold Voltage vs Junction Temperature

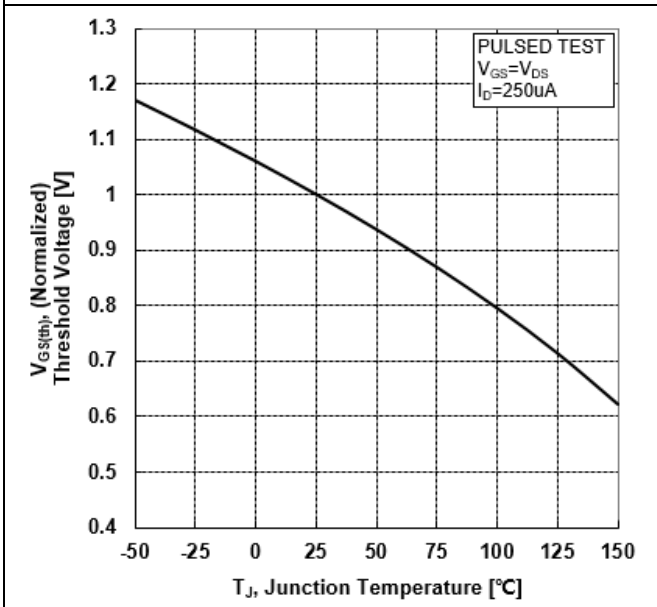

Figure 11. Normalized Breakdown Voltage vs Junction Temperature

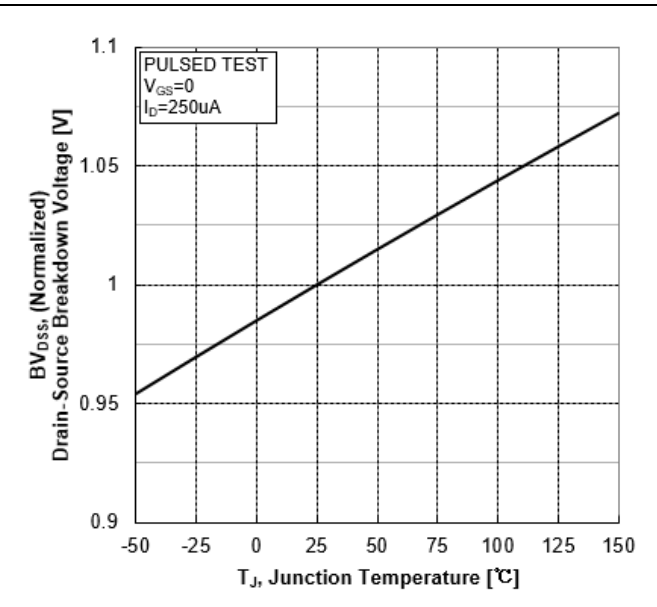



Figure 12. Capacitance Characteristics

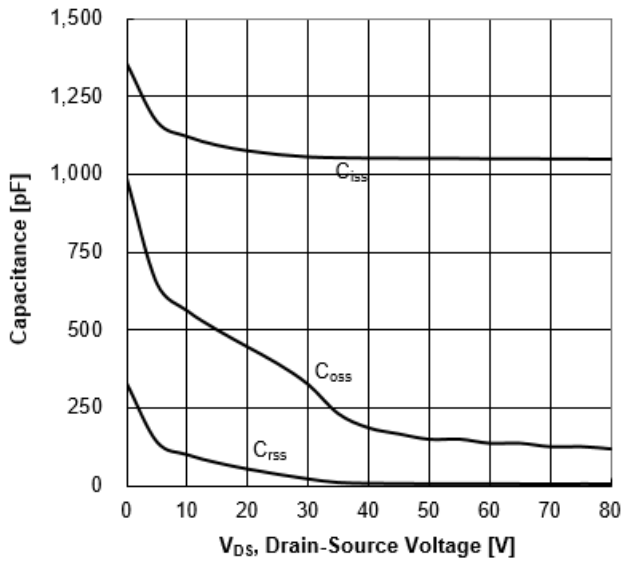
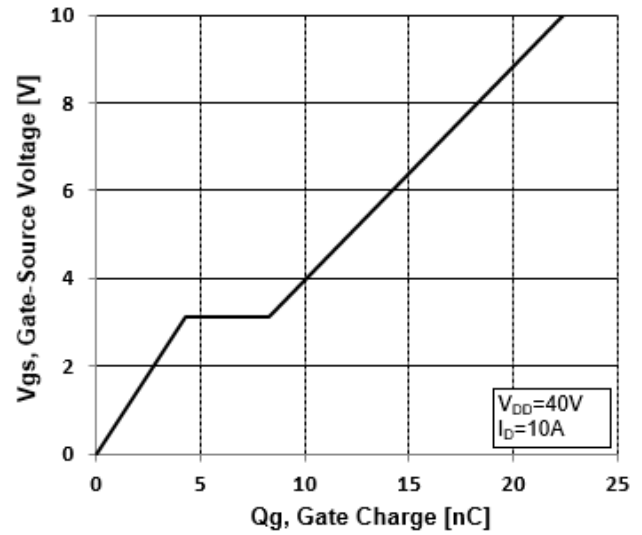

Figure 13. Typical Gate Charge vs Gate-Source Voltage





6. Test Circuit and Waveform

Figure 14. Resistive Switching Test Circuit

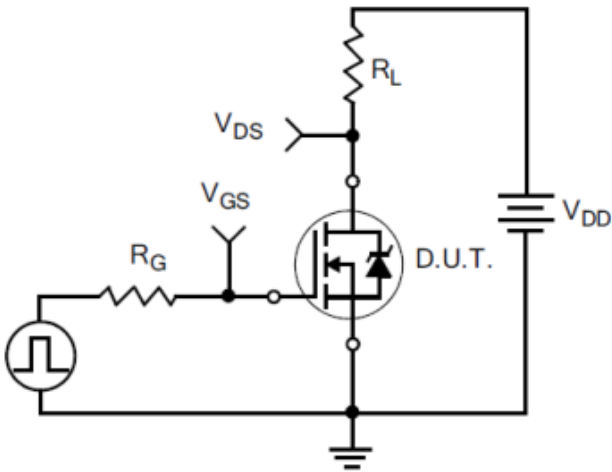

Figure 15. Resistive Switching Waveforms

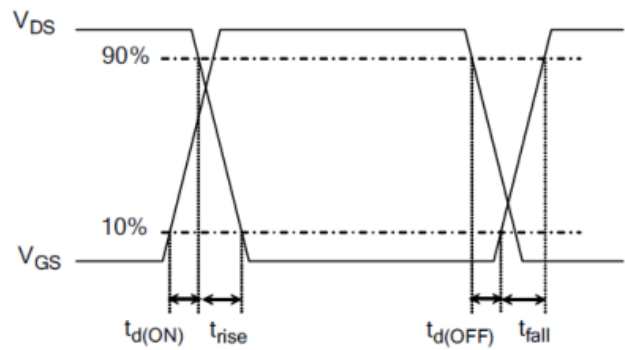

Figure 16. Gate Charge Test Circuit

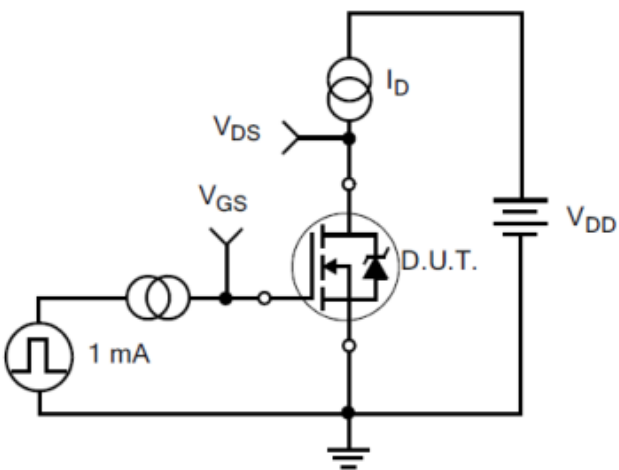

Figure 17. Gate Charge Waveforms

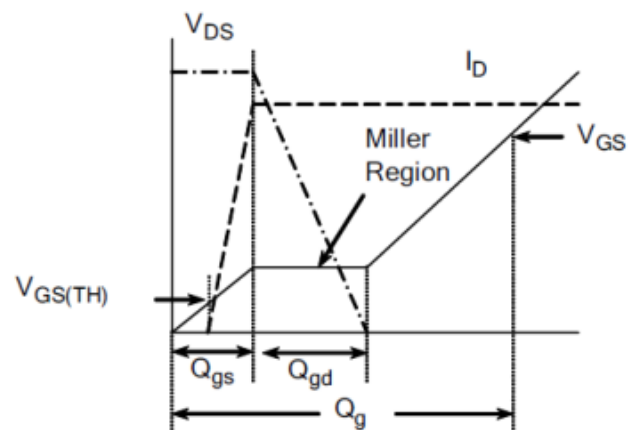



Figure 18. Diode Reverse Recovery Test Circuit

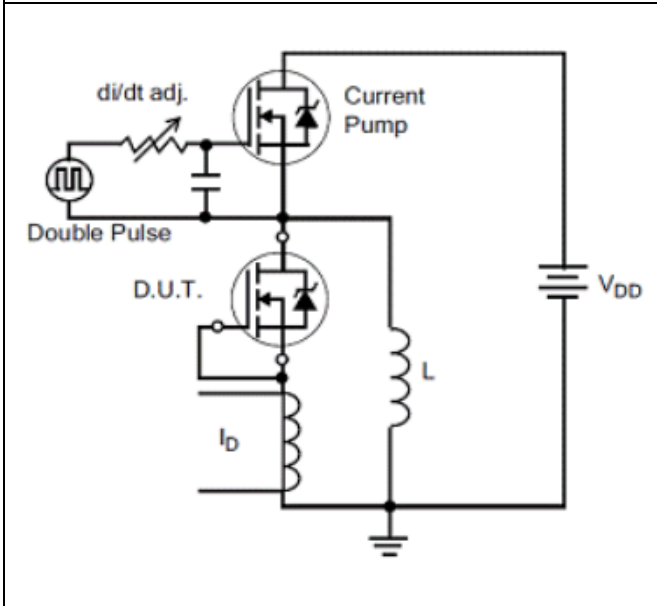

Figure 19. Diode Reverse Recovery Waveform

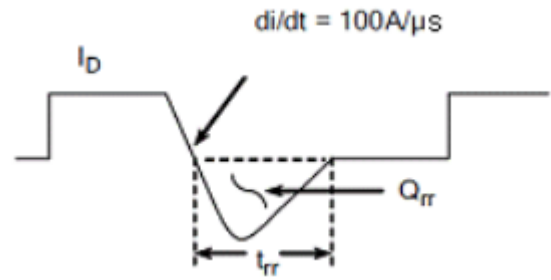

Figure 20. Unclamped Inductive Switching Test Circuit

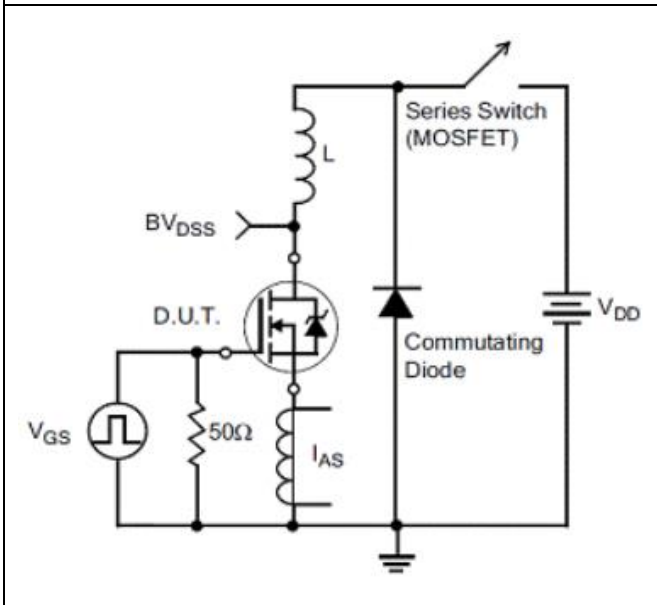
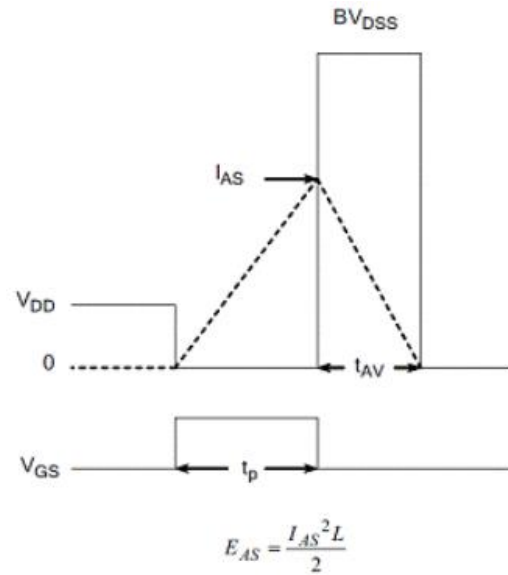
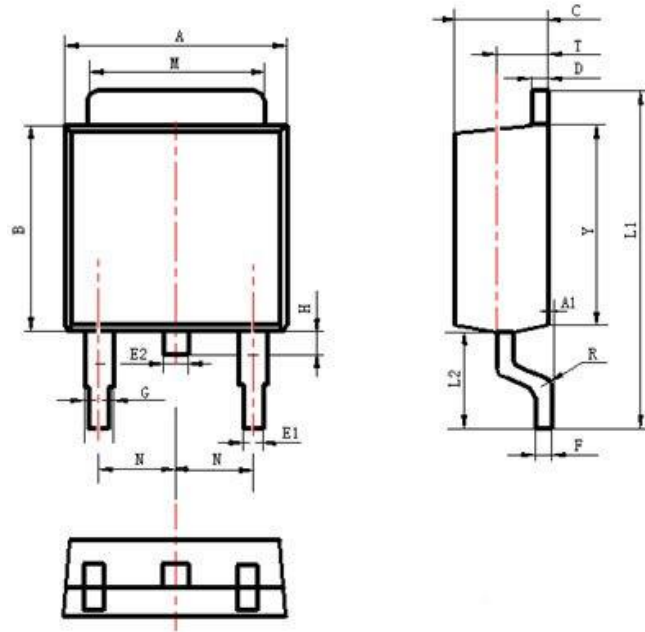

Figure 21. Unclamped Inductive Switching Waveform



7. Package Description

TO-252



Items	Values(mm)	
	MIN	MAX
A	6.30	6.90
A1	0	0.13
B	5.70	6.30
C	2.10	2.50
D	0.30	0.60
E1	0.60	0.90
E2	0.70	1.00
F	0.30	0.60
G	0.70	1.20
L1	9.60	10.50
L2	2.70	3.10
H	0.60	1.00
M	5.10	5.50
N	2.09	2.49
R	0.3	0.3
T	1.40	1.60
Y	5.10	6.30



PDFN5*6

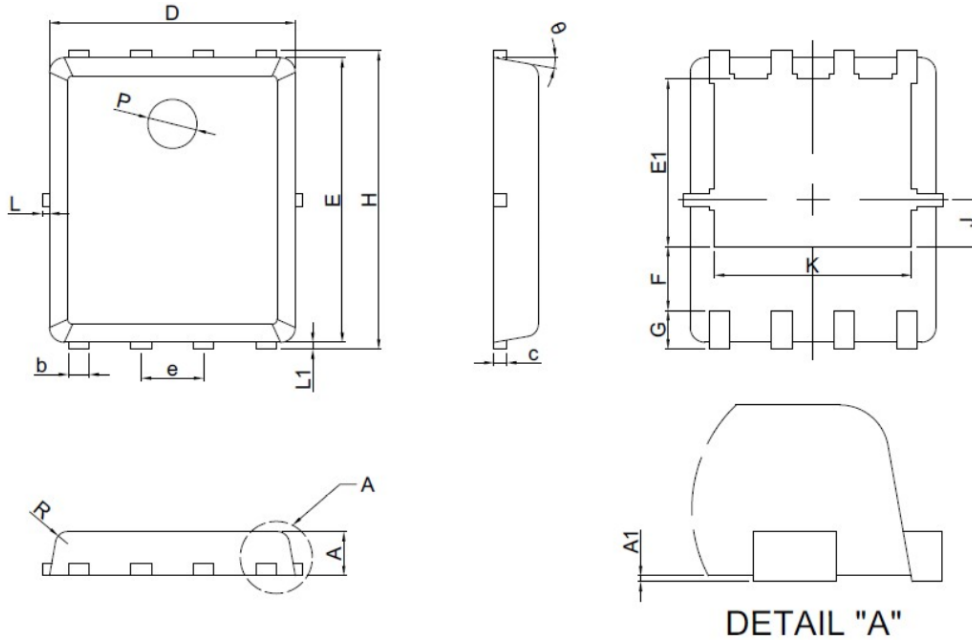

SYMBOL	MIN	NORMAL	MAX
A	0.8	0.9	1.0
A1	0.00	0.03	0.05
b	0.35	0.42	0.49
c	0.254REF		
D	4.9	5.0	5.1
F	1.40REF		
E	5.7	5.8	5.9
e	1.27BSC		
H	5.95	6.08	6.20
L1	0.10	0.14	0.18
G	0.60REF		
K	4.00REF		
L	-----	-----	0.15
J	0.95BSC		
P	1.00REF		
E1	3.35	3.40	3.65
θ	6°	10°	14°
R	0.25REF		



NOTE:

1. Exceeding the maximum ratings of the device in performance may cause damage to the device, even the permanent failure, which may affect the dependability of the machine. Please do not exceed the absolute maximum ratings of the device when circuit designing.
2. When installing the heat sink, please pay attention to the torsional moment and the smoothness of the heat sink.
3. MOSFETs is the device which is sensitive to the static electricity, it is necessary to protect the device from being damaged by the static electricity when using it.
4. Shanghai Jerrett reserves the right to make changes in this specification sheet and is subject to change without prior notice.